

*Albemarle County, Virginia*

# Typical Finished Basement Details

Based on the 2021 Virginia Residential Code



Finished basements must be constructed in conformance with this document. For requirements, details and information not contained herein, you must consult the Virginia Residential Code. Code books may be viewed [online](https://www.iccsafe.org) or purchased from the International Code Council at [iccsafe.org](https://www.iccsafe.org). A copy of this document is required to be on the job site and available to the inspector during each required inspection.

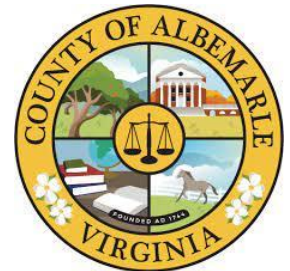

*Albemarle County, Virginia*  
**Typical Finished Basement Details**

**CONTENTS**

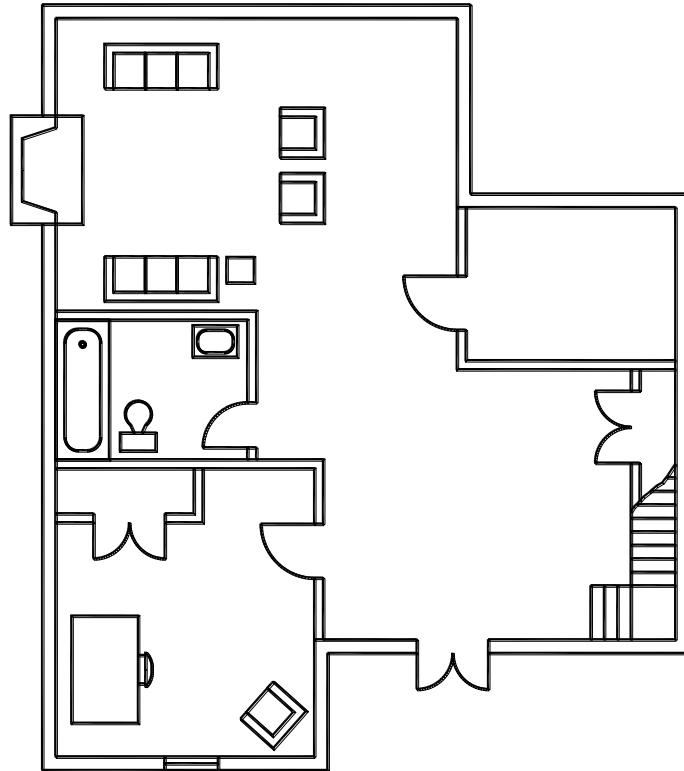

**Section 1** ▪ **General Notes** .....4  
**Section 2** ▪ **Emergency Escape and Rescue**.....4  
**Section 3** ▪ **Wall Construction** .....6  
**Section 4** ▪ **Drilling and Notching** .....8  
**Section 5** ▪ **Floor/ceiling Construction**.....9  
**Section -4** ▪ **Mechanical**.....9  
**Section 7** ▪ **Plumbing** .....10  
**Section 8** ▪ **Electrical** .....11



# I - GENERAL NOTES

1. Habitable rooms (excluding closets, hallways, laundry rooms, storage spaces and bathrooms) shall have an area of not less than 70 square feet and shall not be less than 7 feet in any direction.
2. Hallways shall not be less than 36 inches in width.
3. Basement ceiling height shall not be less than 7 feet above the finished floor. Beams, girders, ducts or other obstructions may project to within 6 feet 4 inches of the finished floor.
4. Bathrooms shall be equipped with a fan vented directly to the outside. A fan is not required if the bathroom contains an operable window with an opening of 2 square feet or more.
5. Space under stairs shall be protected with ½-inch drywall on the underside or with a non-accessible enclosure clad in ½-inch drywall.
6. A smoke alarm shall be installed in the basement and in each basement bedroom. New smoke alarms shall be interconnected so that when one is activated all will sound. Smoke alarms must be hardwired with a battery backup. Smoke alarms must be installed at least 3 feet from doorways to bathrooms with tubs or showers, where possible (if adding a bedroom and the house is equipped with a gas-fired appliance, a carbon monoxide alarm installed in the basement is highly recommended).
7. All basement stairs shall have a light source to illuminate all treads and landings. Lights shall be operated by a switch located at the top and bottom of the stairs.
8. A minimum of R-15 battened insulation (optional, with a vapor barrier on the warm side of the wall) shall be installed for the full height and length of the basement wall.
9. Finished basements that include a kitchen, wet bar or bedroom require a plan submission and approval by the county.
10. Cutting openings in existing basement walls is outside the scope of these details. Therefore, a plan submission is required.
11. Deviations from these details require approval by county staff prior to construction.

# 2 - EMERGENCY ESCAPE AND RESCUE

**Where required.** An emergency escape and rescue opening (EERO) in the form of a window or door to the outside is required in basements of houses constructed after October 1, 2003 and all basement bedrooms regardless of when they are constructed. An EERO in a bedroom may serve the entire basement.

**Emergency escape and rescue opening options.** The following openings can be used for emergency escape and rescue.

- Window in a walk-out basement condition.
- Window to a window well or areaway.
- Door in a walk-out basement condition.
- Door to an areaway.
- Door to bulkhead enclosure (Bilco door or similar).

**Opening requirements.** The emergency escape and rescue opening shall meet the requirements below.

- See FIGURE 1 for typical window opening requirements.
- All doors and windows must be operable from the inside without the need of a key or tool.
- The opening must be a minimum of 5.7 square feet<sup>1</sup>.
- Windows must have a sill 44 inches or less above the finished floor.

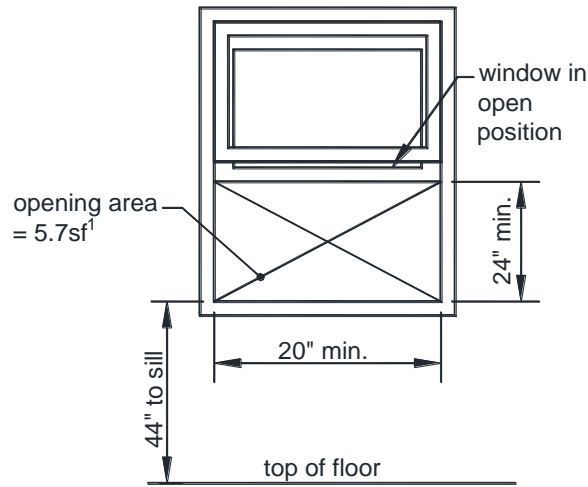

<sup>1</sup> Windows opening directly to outside in a walk-out condition are permitted to have an opening area equal to 5.0 square feet.

**FIGURE 1: EMERGENCY ESCAPE AND RESCUE OPENING REQUIREMENTS**

**Window well requirements.** When grade conditions require the sill of the window to be below the outside grade elevation, then a window well must be constructed. The minimum required horizontal area of a window well is 9 square feet as measured when the window is in the open position (this is important when the window is a crank-out type). See FIGURE 2.

**Window well construction.** A plan submission to the county is required for the construction of a new window well. If you choose to use a prefabricated window well, you must submit the manufacturer's specification during the permit application process.

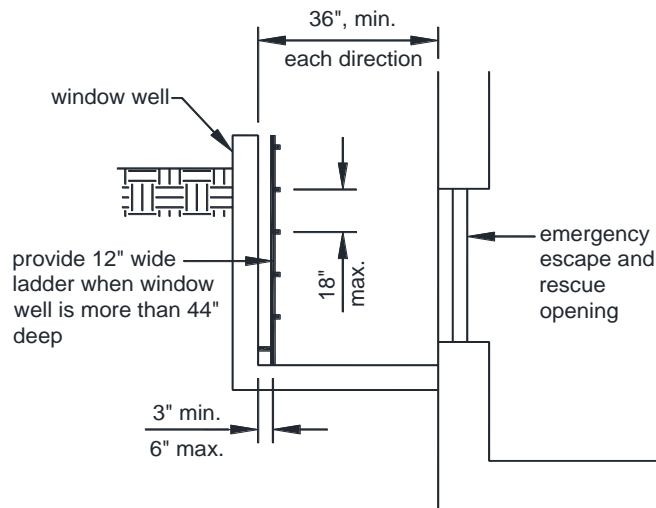

**FIGURE 2: WINDOW WELL REQUIREMENTS**

**Ladder requirements.** When a window well is deeper than 44 inches, a permanent, attached ladder or steps must be provided per FIGURE 2. If the ladder projects more than 6 inches into the required horizontal area, the size of the window well must be increased to compensate.

## 3 - WALL CONSTRUCTION

**Studs.** Studs may be utility grade or better. Walls shall have a single pressure treated bottom plate and can have a single or double top plate. Studs shall be placed at 16 inches on center, but may be increased to a 24 inches on center when applied finish material is drywall.

**Attachment requirements.** Wall construction shall be fastened in accordance with TABLE 1.

**TABLE 1: FASTENING SCHEDULE**

CONNECTION	NAILING METHOD	FASTENER
Top plate or bottom plate <sup>1</sup> to stud	Toe nail	3-16d box (3½" x 0.135") or 4-8d box (2½" x 0.113")
	or end nail	3-16d box (3½" x 0.135") or 2-16d common (3½" x 0.162")
Bottom plate to floor	Face nail	16d concrete nail (3½" x 0.135") @ 16"o.c.
Header to jack stud (see FIGURE 3)	Toe nail	4-8d (2½" x 0.113") each side of header at each end

<sup>1</sup>Bottom plate fasteners are required to be hot-dipped galvanized.

**Headers.** A single flat 2x4 may be used as a header in interior nonbearing walls for openings up to 8 feet in width if the portion of the wall above the opening is not more than 24 inches in height. If the opening does not meet these conditions, the header shall be framed per FIGURE 3 and sized per TABLE 2. Two-ply headers shall be fastened together using 16d common (3½" x 0.162") face nails at 16 inches on center, or 16d box (3½" x 0.135") face nails at 12 inches on center, staggered along the top and bottom edges.

**TABLE 2: HEADER SIZE<sup>1</sup>**

HEADER SIZE	SPAN LENGTH, FEET
(2)2x4	4
(2)2x6	6
(2)2x8	10
(2)2x10	12
(2)2x12	16

<sup>1</sup>Non-load bearing walls only.

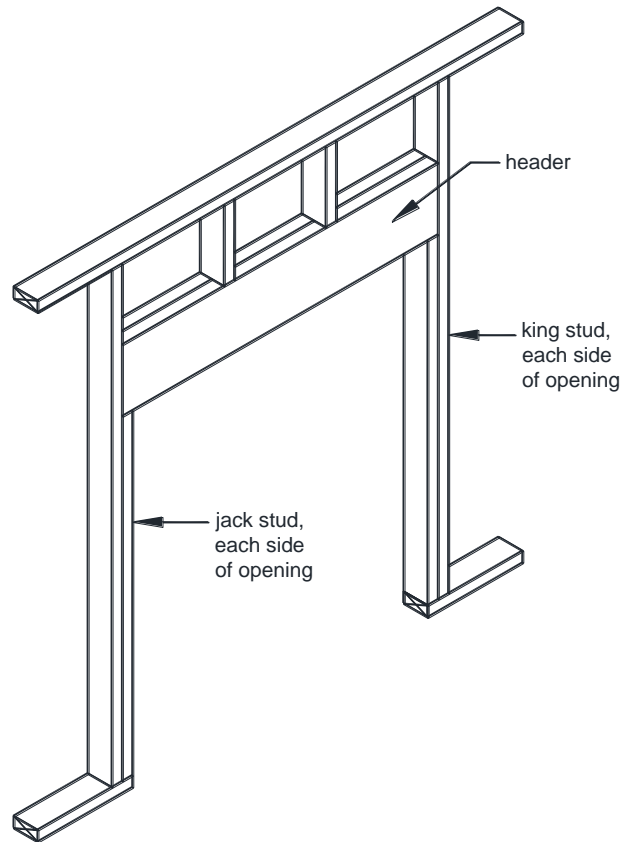

**FIGURE 3: FRAMING AT HEADERS**

**Fireblocking.** Fireblocking shall be provided to seal off concealed spaces and to form an effective fire barrier between stories. Fireblocking shall be provided in the following locations.

- In concealed spaces of stud walls and partitions, including furred spaces at the ceiling and floor level where the top plate is attached to the underside of the floor joists. See FIGURE 4.
- At all interconnections between concealed vertical and horizontal spaces such as occur at soffits, bulkheads, drop ceilings, etc. See FIGURE 5.
- In concealed spaces of stud walls offset from the basement wall. See FIGURE 6
- In concealed spaces between stair stringers at the top and bottom of the stair run.
- At gaps and openings around vents, pipes and ducts at the ceiling and floor level.

**Fireblocking material.** Fireblocking shall consist of one of the materials listed below.

- ½-inch gypsum board.
- 2x lumber (2x4, 2x6, etc.).
- Two thicknesses of 1x lumber (1x4, 1x6, etc.) with staggered joints.
- ¾-inch plywood, OSB or particleboard with joints backed by 6 inches of the same material.
- ¼-inch cement, cement/fiber board (e.g., Durock).
- At gaps 1 inch or less, batts or blankets of mineral wool or fiberglass pack tightly to remain in-place or approved fireblocking caulk.

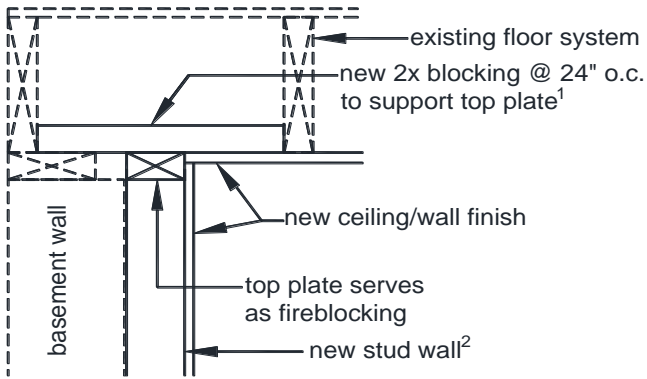

<sup>1</sup> Attach top plate to underside of joists where floor framing is perpendicular to stud wall.

<sup>2</sup> R-13 insulation should be provided between studs.

**FIGURE 4: FIREBLOCKING WITH STUD WALL AGAINST BASEMENT WALL**

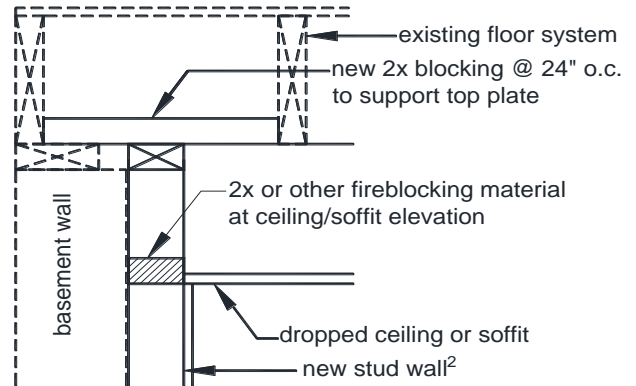

<sup>1</sup> Attach top plate to underside of joists where floor framing is perpendicular to stud wall.

<sup>2</sup> R-13 insulation should be provided between studs.

**FIGURE 5: FIREBLOCKING AT DROP CEILING**

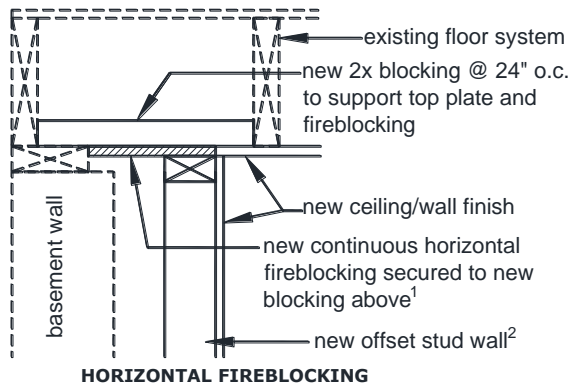

**HORIZONTAL FIREBLOCKING**

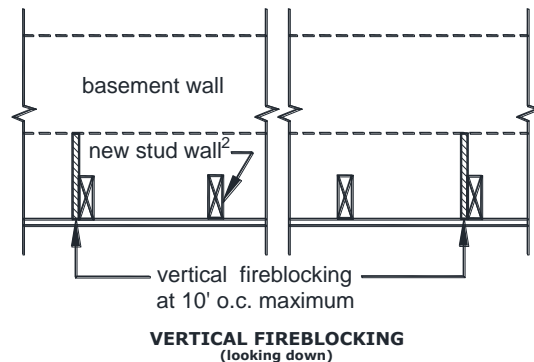

**VERTICAL FIREBLOCKING (looking down)**

<sup>1</sup> Attach top plate and fireblocking to underside of joists where floor framing is perpendicular to stud wall.

<sup>2</sup> If cavity between basement wall and new stud wall does not contain existing insulation, then R-13 insulation should be installed.

**FIGURE 6: FIREBLOCKING WITH OFFSET STUD WALL**

**Interior finishes.** Wall and ceiling finish materials must meet the requirements listed below.

- Materials must have a flame spread classification no greater than 200, except for trim, molding, handrails and doors, and must have a smoke density classification no greater than 450.
- Cement or fiber-cement board (e.g., Durock) must be installed on walls of bathtub and shower spaces and finished with a non-absorbent surface.
- Wood veneer or hardboard paneling less than 1/4-inch shall not be permitted.
- Gypsum board must be 1/2-inch minimum.

## 4 ■ DRILLING AND NOTCHING

**Studs.** Studs in interior non-loadbearing walls may be notched or drilled in accordance with FIGURE 7.

**Joists and/or beams.** Drilling and notching of wood joists and beams shall meet the requirements below.

- Drilling and notching 2x lumber shall be in conformance with FIGURE 8. Cantilevered (overhanging) joists cannot be notched.
- Drilling and notching of manufactured wood I-joists, LVL or other engineered wood product shall be per the manufacturers' instructions.
- Drilling and notching of open web floor trusses is prohibited without submitted calculations performed by a registered design professional licensed in Virginia.

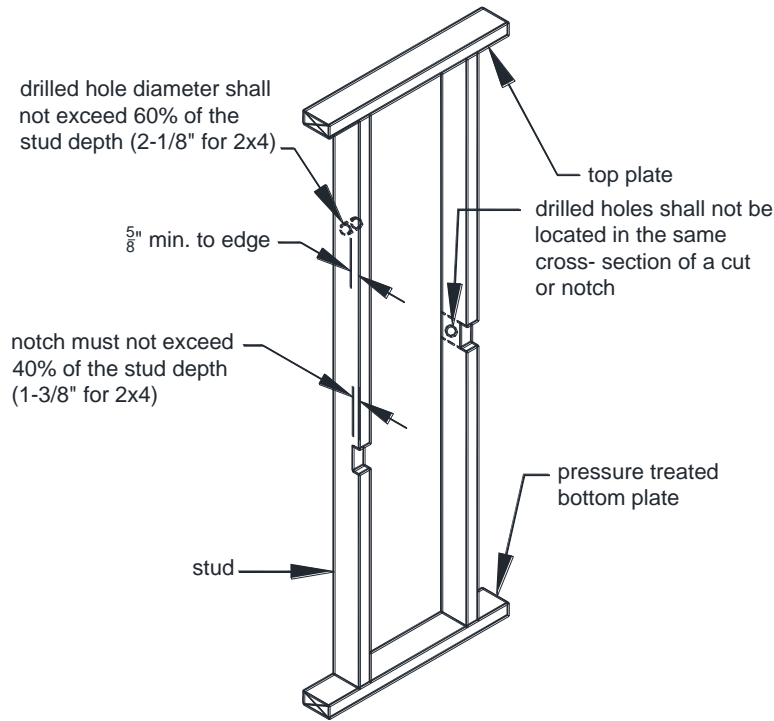

**FIGURE 7: DRILLING AND NOTCHING INTERIOR NON-LOADBEARING STUDS**

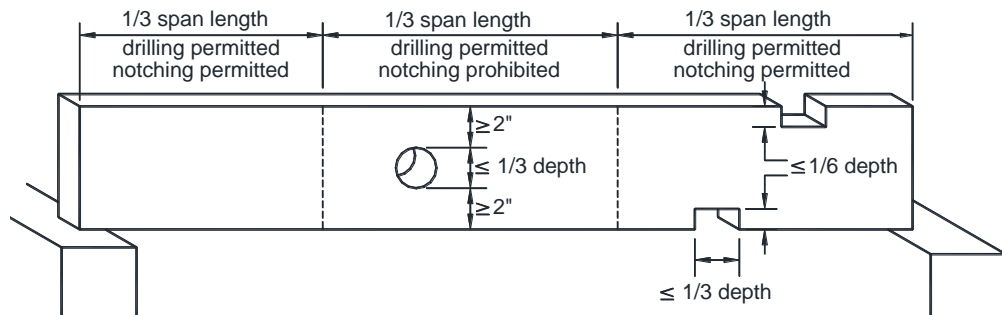

**FIGURE 8: DRILLING AND NOTCHING JOISTS**

## 5 ■ FLOOR/CEILING CONSTRUCTION

**Draftstopping.** When a ceiling is not directly attached to the underside of the floor joists above or when the floor joists are comprised of open web trusses, draftstopping must be provided. Install draftstopping to create equal-sized concealed areas not exceeding 1,000 square feet. Draftstopping shall be installed parallel to the floor framing members. See FIGURE 9 and FIGURE 10.

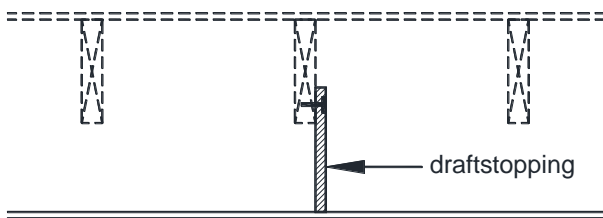

**FIGURE 9: DRAFTSTOPPING AT DROP CEILING**

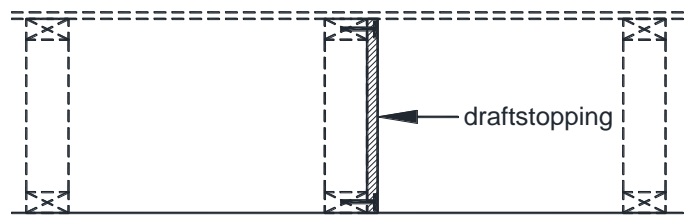

**FIGURE 10: DRAFTSTOPPING AT OPEN WEB TRUSSES**

**Draftstopping material.** Draftstopping shall consist of 1/2-inch minimum gypsum board, 3/8-inch minimum wood plywood/OSB or 3/8-inch minimum particleboard, Type 2-M-W.

## 6 - MECHANICAL

**Appliance access.** Furnaces, water heaters and other appliances must be accessible without removing permanent construction and shall meet the following minimum criteria.

- 30 inches x 30 inches clear floor space at front/control side.
- Doors to furnace rooms shall be 24 inches minimum and be of sufficient size to remove the largest appliance.

**Combustion air.** Furnace rooms with fuel-fired appliances must be provided with two permanent openings to adjacent spaces: one within 12 inches of the top and one within 12 inches from the bottom of the adjoining wall. Each opening must have a minimum free area equal to 1 square inch per 1,000 Btu per hour input rating of all appliances in the furnace room, but not less than 100 square inches. The openings are not required if a louvered door is provided or the furnace room area is greater than 50 cubic feet per 1,000 Btu per hour input rating of all appliances installed in the room.

## 7 - PLUMBING

**Showers.** Showers and shower compartments must meet the following requirements.

- Shower compartments must have a minimum total area of 900 square inches and a minimum dimension of 30 inches in any direction.
- Shower compartments may have a minimum dimension of 25 inches provided it maintains a cross sectional area of 1,300 square inches.
- Hinged shower doors must open outward.
- All glass which encloses a shower must be safety glazed.
- Shower control valves must be scald resistant (in accordance with ASSE/ANSI 1016) with a hot water limit of 120 degree F.

**Fixture clearances.** Toilets, sinks and showers shall have the minimum clearances listed below.

- 21 inches in front of sinks and toilets.
- 24 inches in front of shower stall opening.
- 4 inches between two adjacent sinks.
- 4 inches between a sink and a toilet.
- 4 inches between a sink and a wall.
- 2 inches between a sink and a bathtub.
- 15 inches clearance from a toilet's centerline to an adjacent fixture or wall on each side.

**Drain size.** Fixture drain size must meet the dimensions below and must be equipped with a strainer and stopper.

**TABLE 3: MINIMUM DRAIN SIZE**

FIXTURE	DIAMETER, INCHES
Bathroom sink	1¼
Bathtubs	1½
Sinks (other than bathroom)	1½
Laundry tubs	1½
Shower	1½

**Clothes washer discharge.** The discharge of a clothes washer must be through and air break as shown in FIGURE 11.

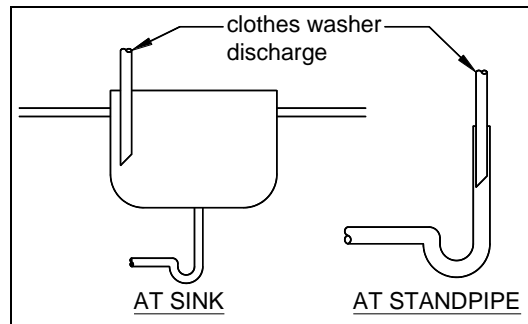

**FIGURE 11: AIRBREAK AT CLOTHES WASHER DISCHARGE**

## 8 - ELECTRICAL

**Panelboard (circuit breaker box).** Panel boards must meet the requirements listed below.

- A workspace 30 inches wide and 36 inches deep from floor to the ceiling with a minimum height of 6.5 feet shall be provided in front of the panel boards.
- Panel board workspace must not be used for storage at any time.
- Panel boards must not be located in clothes closets or bathrooms.
- A light shall be provided for the panel board workspace.
- Pipes or ducts cannot be located above the panelboard.

**Branch circuits.** Branch circuits must meet the requirements listed below. See TABLE 4 for more information.

- Use a 15- to 20-ampere rated branch circuit for general use purposes such as lighting and outlets.
- One “plugged-in” electrical device shall not exceed 80 percent of the circuit rating.
- Hardwired appliances or equipment may be included in a general use circuit provided its rating does not exceed 50 percent of the circuit rating.
- A dedicated 20-ampere minimum branch circuit must be provided to serve laundry room outlets only.
- A dedicated 20-ampere branch circuit must be provided to serve the bathroom receptacles.
- Branch circuits that supply 120 volt, single phase, 15 and 20 ampere outlets must have circuit breakers equipped as combination arc-fault/over current circuit interrupters.

**TABLE 4: BRANCH CIRCUIT REQUIREMENTS**

CIRCUIT ELEMENT	CIRCUIT RATING		
	15 amp	20 amp	30 amp
Minimum conductor size	14	12	10
Maximum breaker size	15	20	30
Outlets rating	15	15 or 20	30
Maximum load	15	20	30

**Lighting requirements.** Lights must meet the requirements listed below.

- At least one switched light shall be provided in each room and hallway. A switched outlet may be substituted except in bathrooms and hallways. A switched outlet cannot count towards a required outlet, see “Outlets” on page 12.
- At least one switched or pull chain light must be provided in each storage area and at or near heating and air conditioning appliances and equipment.
- Lighting fixtures must not be installed within 3 feet horizontally and 8 feet vertically of a bathtub rim or shower stall threshold. A light fixture may be installed above a shower area if it is constructed so that water cannot enter or accumulate in wiring areas and the lighting fixture is marked “suitable for wet locations.”

**Outlets.** Outlets must meet the requirements listed below.

- Outlets shall be tamper resistant.
- Outlets shall be placed in accordance with FIGURE 12.
- The minimum wall length which requires an outlet is 2 feet.
- Kneewalls, built-in bars and other fixed room dividers must be included for outlet spacing.
- Hallways more than 10 feet long must have a minimum of one outlet.
- Outlets installed for specific appliances must be within 6 feet of the appliance location.
- Bathrooms must have at least one outlet located on a wall adjacent to each basin and within 36 inches of the bathroom sink. All bathroom outlets must have ground fault circuit interrupter (GFCI) protection.
- At least one outlet must be provided to serve laundry appliances and sinks.
- All 125-volt through 250-volt receptacles in the basement is required to have GFCI protected.
- An outlet must be provided within 25 feet of heating and air conditioning appliances and equipment.
- **Arc-fault Exceptions:** AFCI protection is not required for an individual branch circuit supplying only a fire alarm system where the branch circuit is wired with metal outlet and junction boxes and RMC, IMC, EMT or steel-sheathed armored cable Type AC or Type MC meeting the requirements of E3902 in the 2018 VRC.
- AFCI protection is not required where GFCI protection is required in accordance with E3902 in the 2018 VRC.

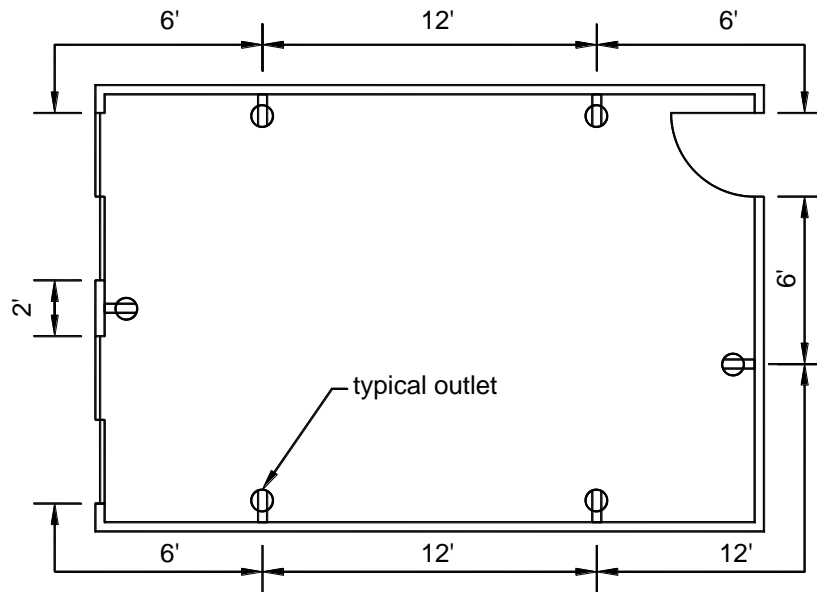

**FIGURE 12: TYPICAL OUTLET DISTRIBUTION**

**Light fixtures in closets.** Fixtures installed in clothes closets shall be limited surface or recess mounted, incandescent or LED fixtures with completely enclosed lamps, surface mounted or recessed fluorescent fixtures, and surface mounted fluorescent or LED fixtures specifically listed for closet use. See TABLE 5 for clearance requirements.

**TABLE 5: CLOSET LIGHT FIXTURE CLEARANCES TO STORAGE AREA<sup>1,2</sup>**

FIXTURE TYPE	LOCATION	FLUORESCENT BULB, INCHES	INCANDESCENT AND LED BULB, INCHES
Surface mounted	Wall above door or ceiling	6	12
Recessed	Any wall or ceiling	6	6

<sup>1</sup> Surface mounted fluorescent and LED bulbs are permitted in storage areas when identified and listed for this use.

<sup>2</sup> Exposed, or partially exposed, incandescent bulbs are prohibited.

\*The entire Virginia Residential Code can be accessed for free at the following link:

<https://codes.iccsafe.org/content/VARC2021P1>