

# POLL PAD<sup>®</sup>

ELECTION DAY POLLWORKER GUIDE

SETUP | TROUBLESHOOTING | CLOSING

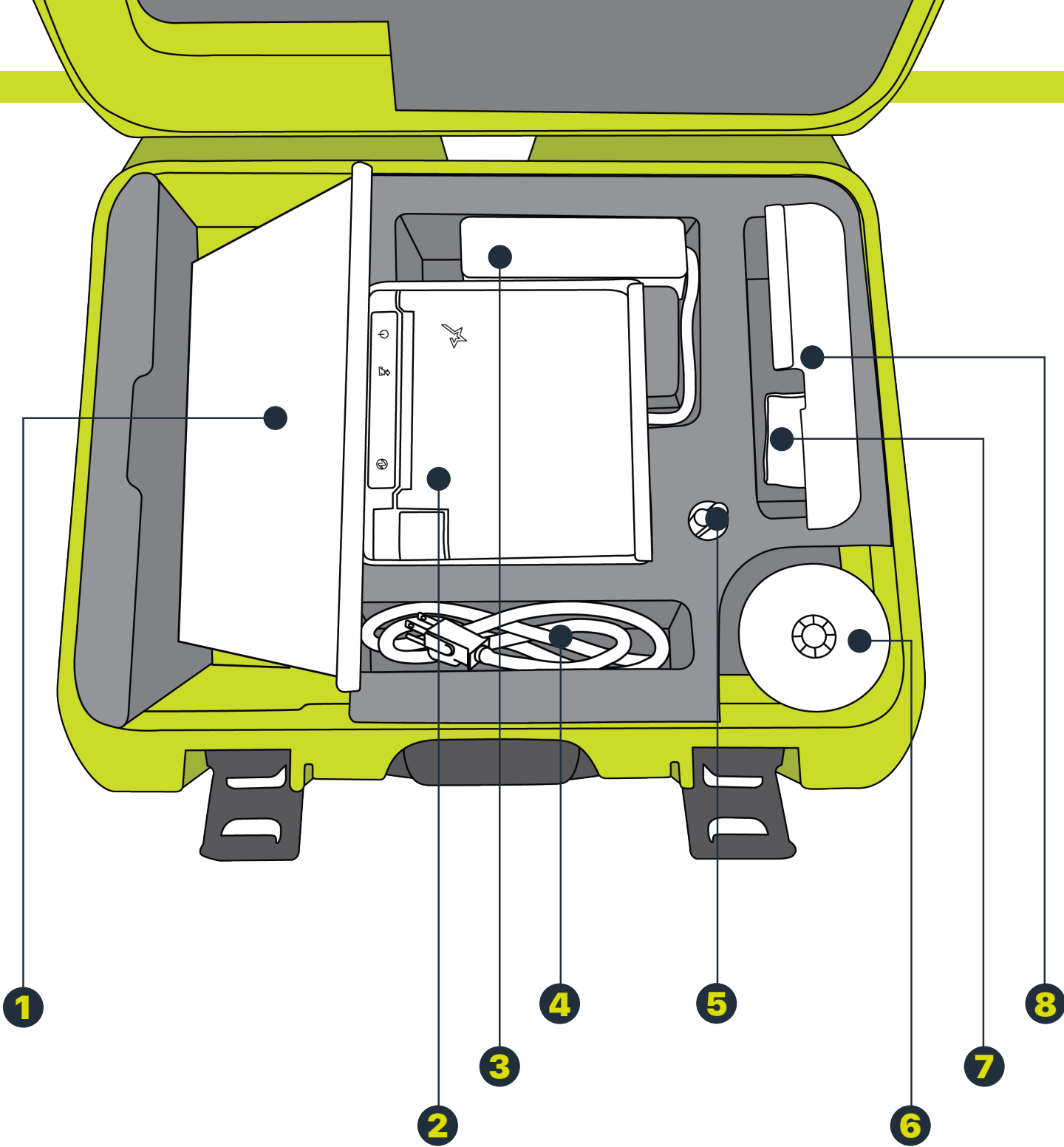

MEET THE  
**POLL PAD**<sup>®</sup>

# **1 POLL PAD**

Attached to the kiosk.

# **2 PRINTER**

Attached to the kiosk.

# **3 POWER ADAPTER**

Attached to the kiosk.

# **4 POWER CORD**

# **5 STYLUS**

# **6 EXTRA PRINTER PAPER**

# **7 CLEANING CLOTH**

# **8 ID TRAY**

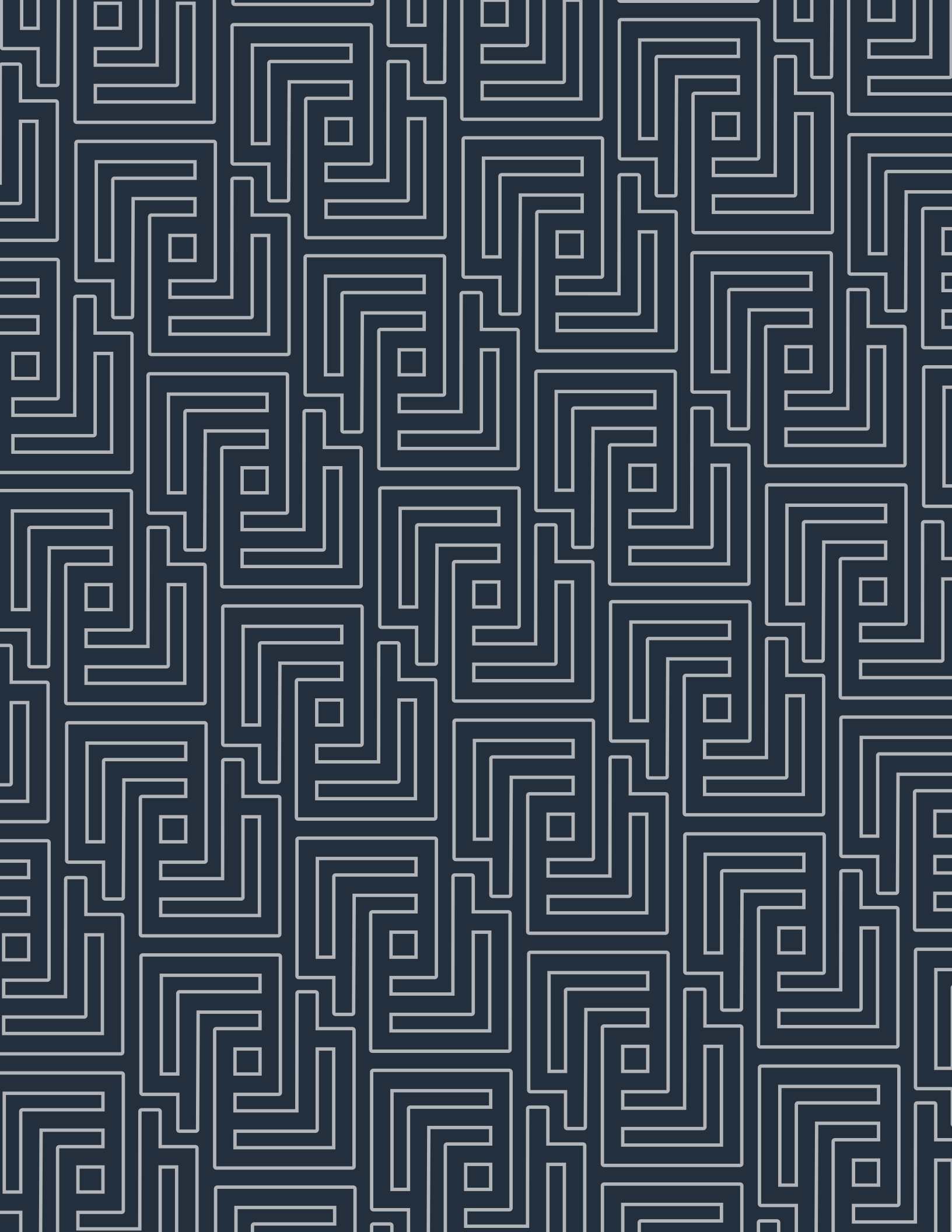

# OPENING PROCEDURES

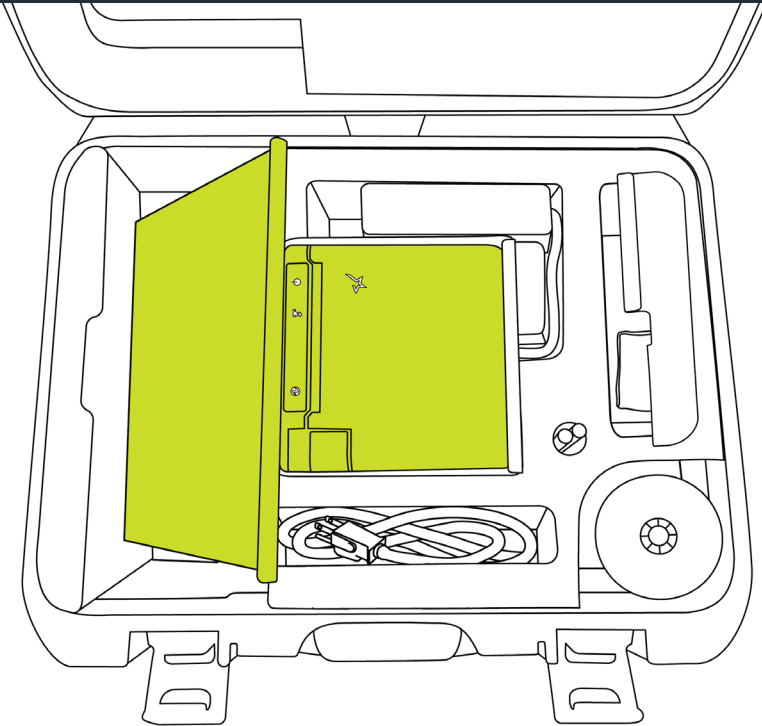

## 1 LOCATE THE POLL PAD KIOSK

Remove the kiosk from the green Poll Pad case.

## 2 CONNECT THE POWER ADAPTER

Connect the power cord into the adapter located on the long printer cord. Ensure a secure connection.

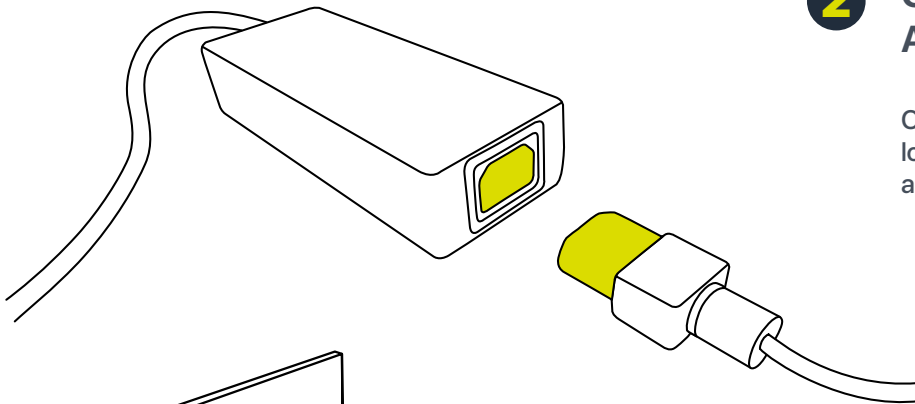

## 3 PLUG THE PRINTER INTO AN OUTLET

Make sure your check-in table is close to the wall outlet or you have an extension cord available.

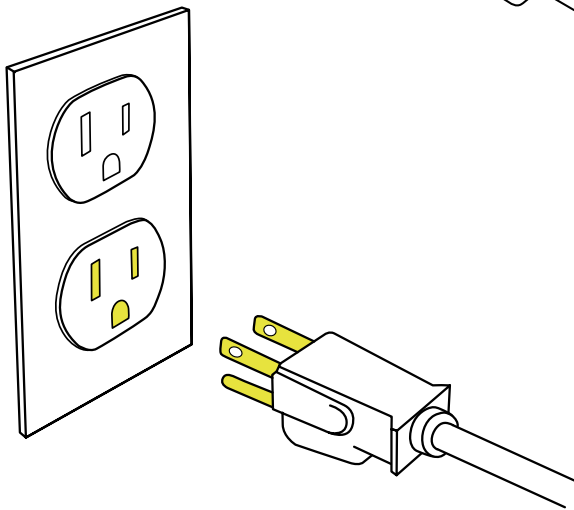

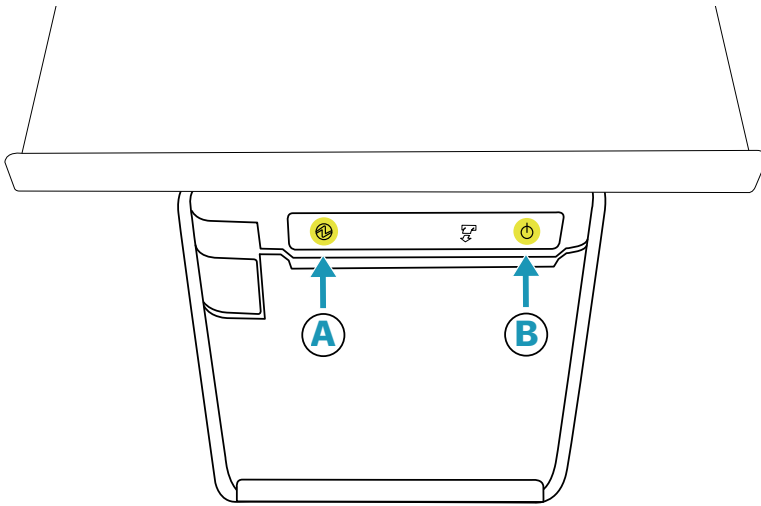

## 4 TURN ON THE PRINTER

- A A blue light indicates the printer is powered on.
- B If there is no blue light push the power button one time.

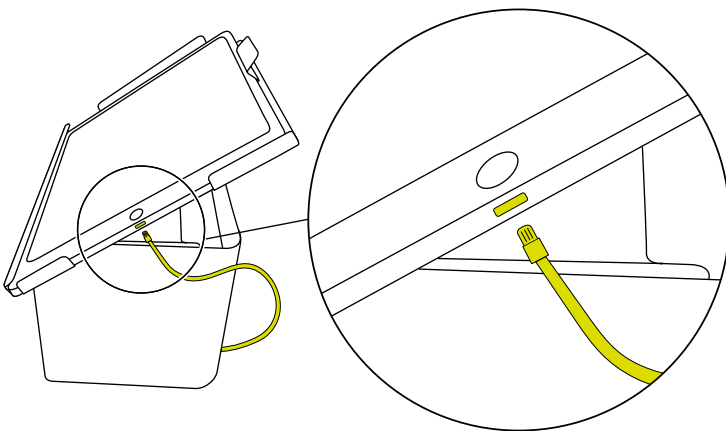

## 5 PLUG IN THE POLL PAD

Plug the small cord into the charging port located on the right side of the Poll Pad. The Poll Pad should power on automatically.

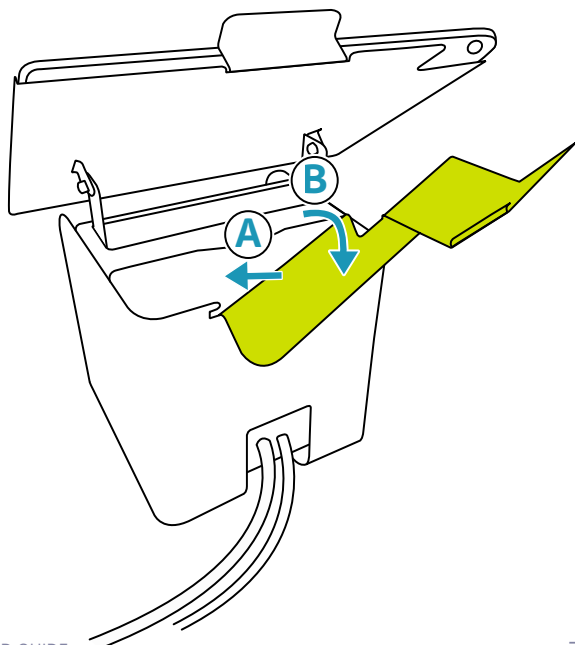

## 6 ATTACH THE ID TRAY

- A Slide the tray under the notch on the back of the printer.
- B Rotate the other side of the tray down to fit into the printer base.

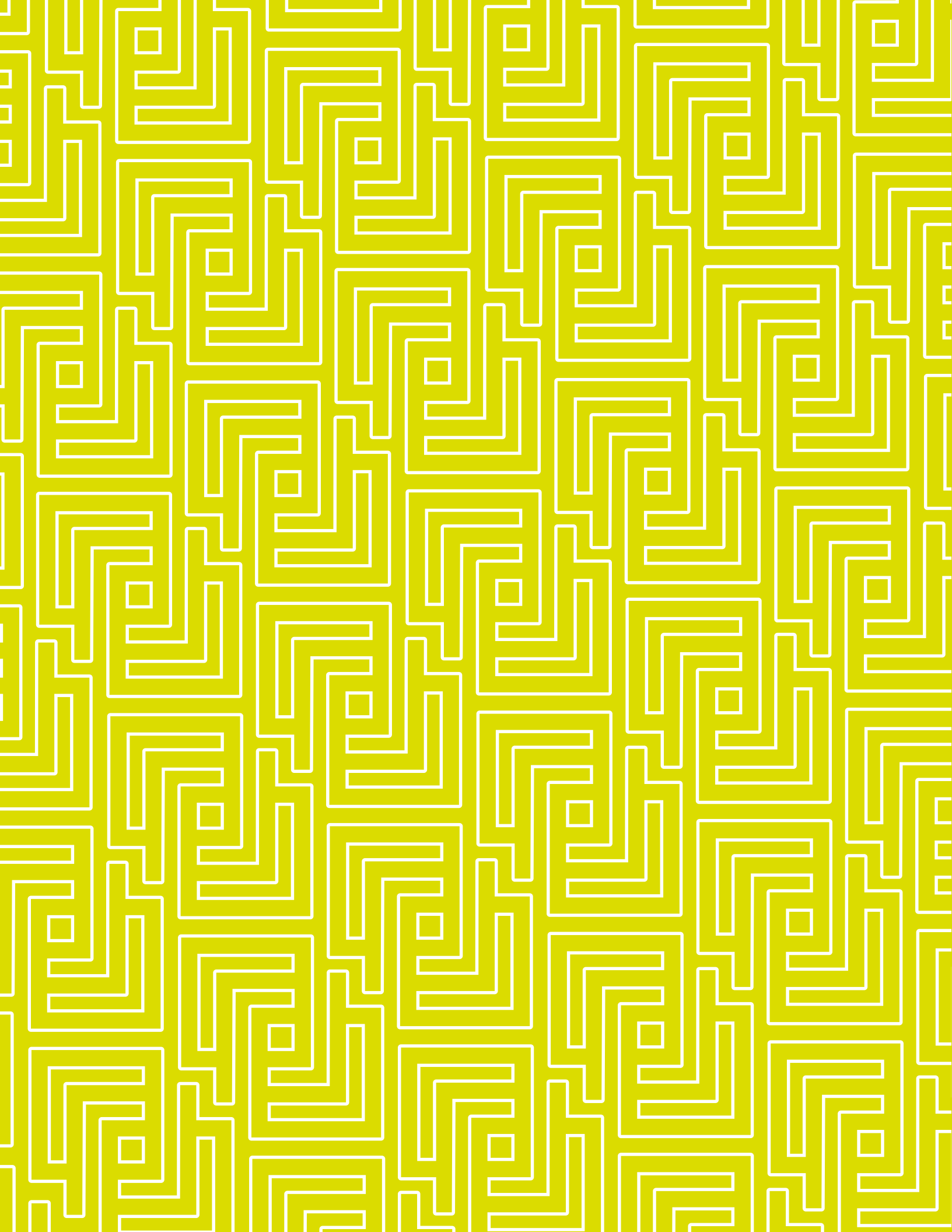

# TROUBLESHOOTING

## PRINTER CONNECTION TROUBLESHOOTING

### Check Bluetooth Connection

#### From Poll Pad:

Verify the printer has power by making sure there is a blue power light on the front of the **A** printer.

#### If the power light is not on:

- 1 Follow the steps for **POLL PAD POWER TROUBLESHOOTING** (page 16).

#### If the power light on the printer is on and the printer is still not connected to the Poll Pad:

- 1 Press home button to go to home screen
- 2 Open Settings on the iPad
- 3 Tap on Bluetooth
- 4 Look for printer under my devices. It should be named something similar to mC-Print3-XXXXX
- 5 If it says Not Connected, tap on the printer name
- 6 If it says Connected tap the Home Button, reopen the Poll Pad app, and verify the printer icon is green

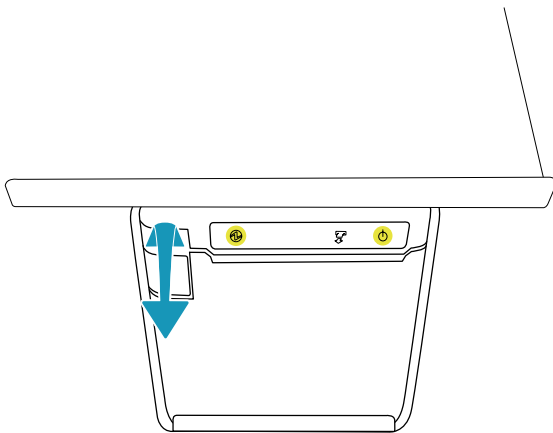
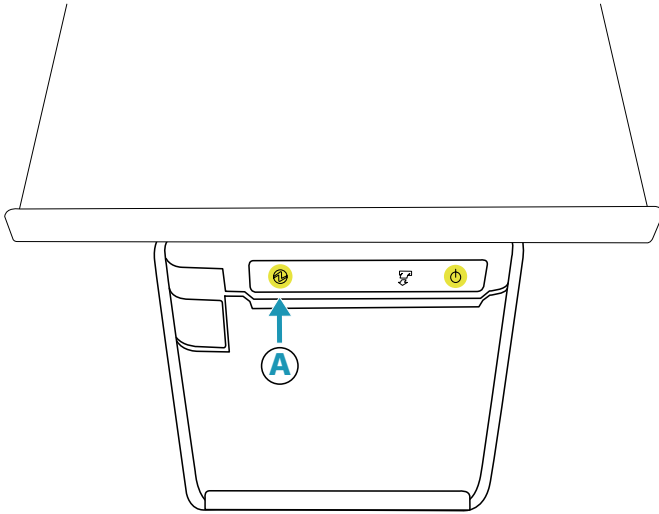

## CHANGING PAPER

- 1 Open the front of the printer by pulling the lever down as indicated in the photo.
- 2 Reload paper with the paper flap toward you, feeding from the top of the roll.
- 3 Close and press **Print Test Receipt**.

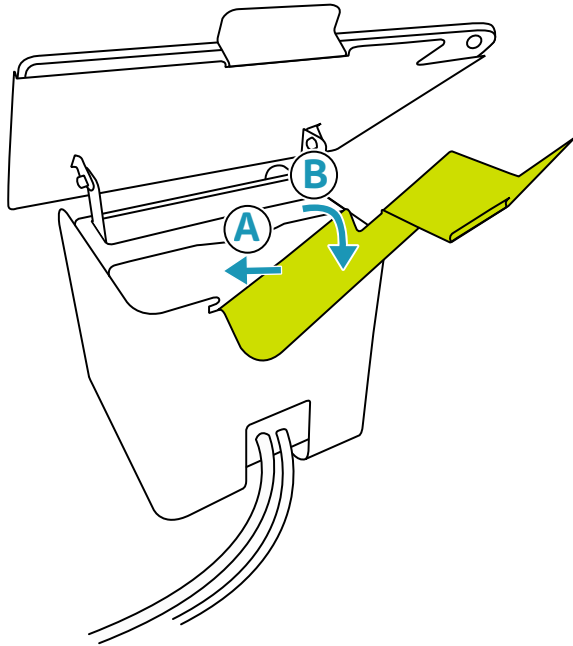

## ID SCANNING TROUBLESHOOTING

The Poll Pad uses the camera on the back of the iPad to scan the barcode on the back of the voter's drivers license or state ID. The Poll Pad ID card tray accessory is designed to hold the ID in the proper location to scan the barcode.

If the barcode will not scan:

- ✓ Make sure the ID tray is connected to the Poll Pad stand correctly
  - ✓ Make sure there are not environmental problems such as a glare on the ID from the lights above the Poll Pad which is common around fluorescent lights
- ❶ If a Poll Pad will not scan the barcode and the above has been checked, try hard resetting the Poll pad (see below)

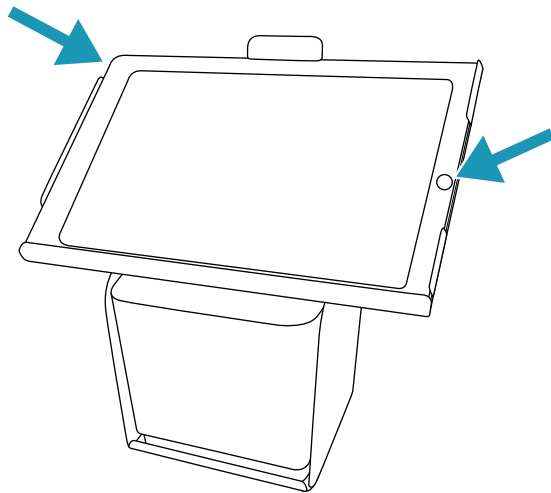

## HARD RESETTING POLL PAD

- ❶ Disconnect the green power cable from the encoder
- ❷ Remove the encoder from the Poll Pad
- ❸ Press and hold the Home Button and the Sleep/Wake button on the Poll Pad until you see the Apple Logo
- ❹ Release the two buttons
- ❺ Launch the Poll Pad app
- ❻ Insert the encoder
- ❼ Wait for the encoder icon to turn green on the Poll Pad
- ❽ Reconnect the green power cable

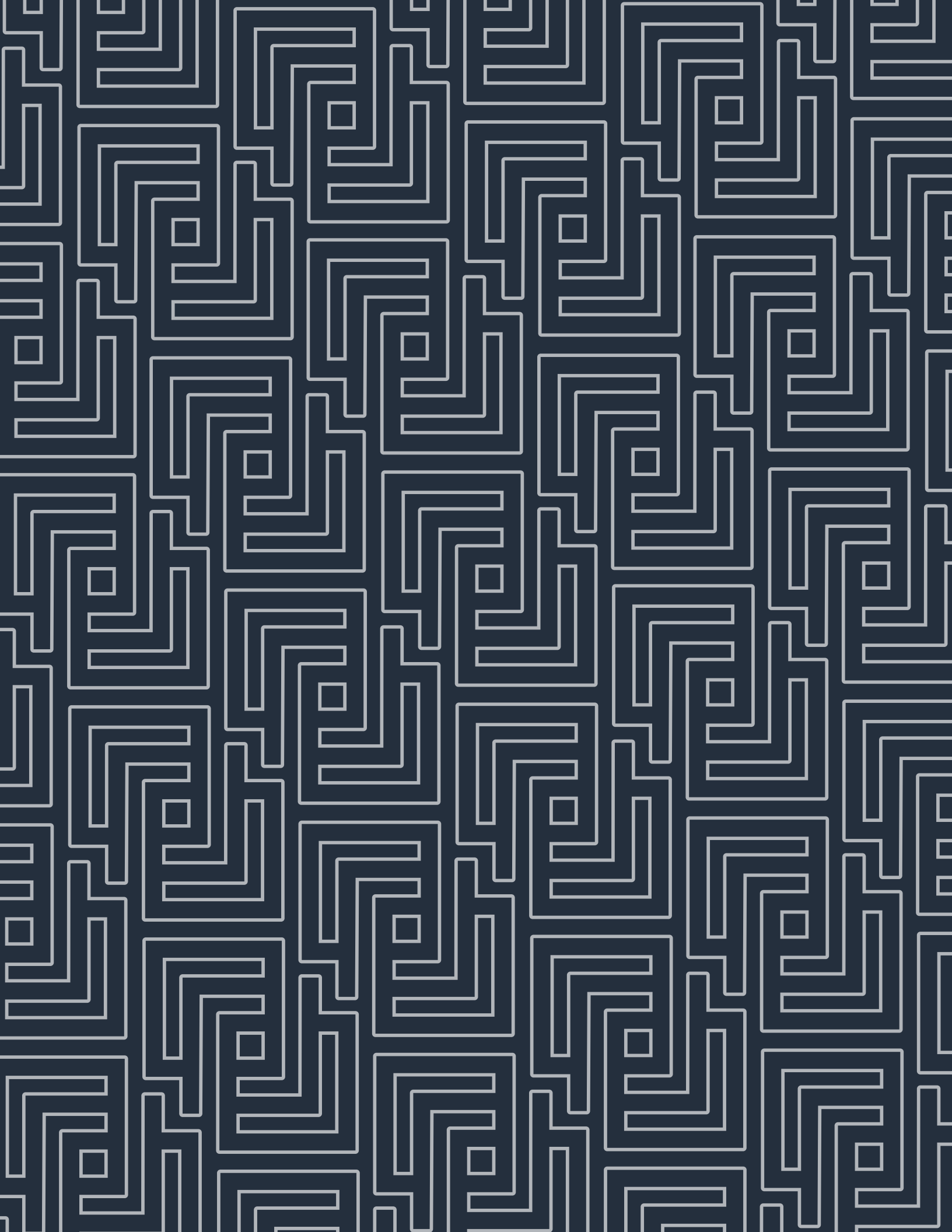

# CLOSING PROCEDURES

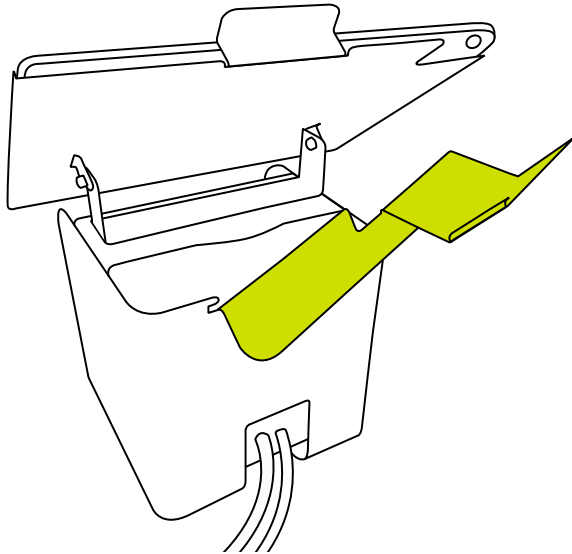

**1** REMOVE THE ID TRAY

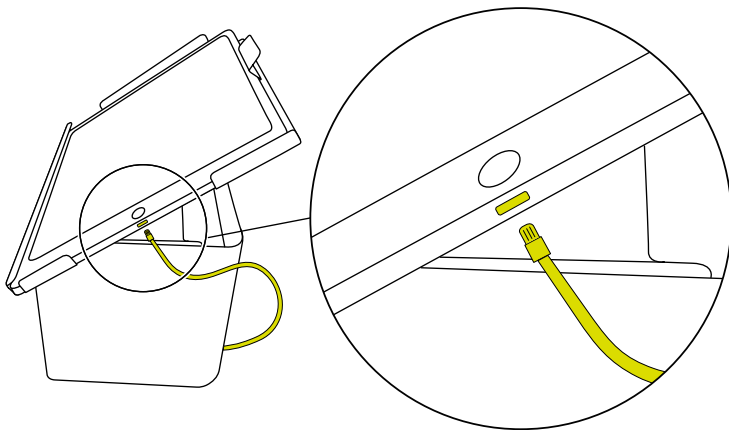

**2** UNPLUG THE POLL PAD

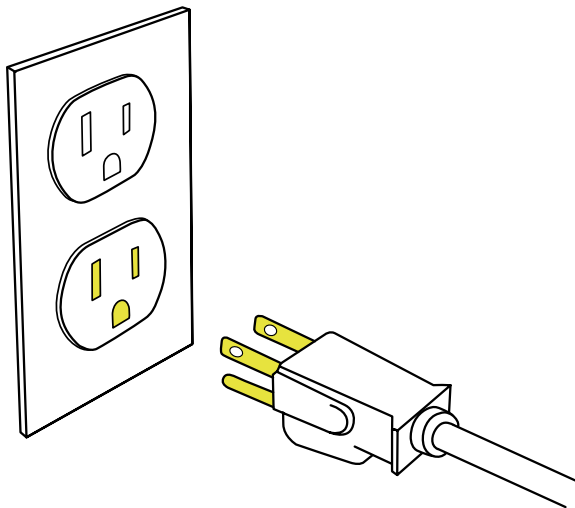

**3** UNPLUG THE PRINTER FROM THE OUTLET

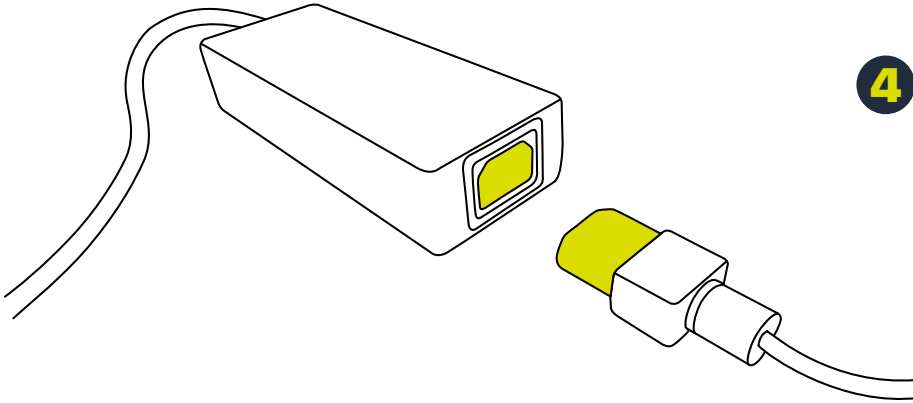

**4 UNPLUG THE POWER ADAPTER**

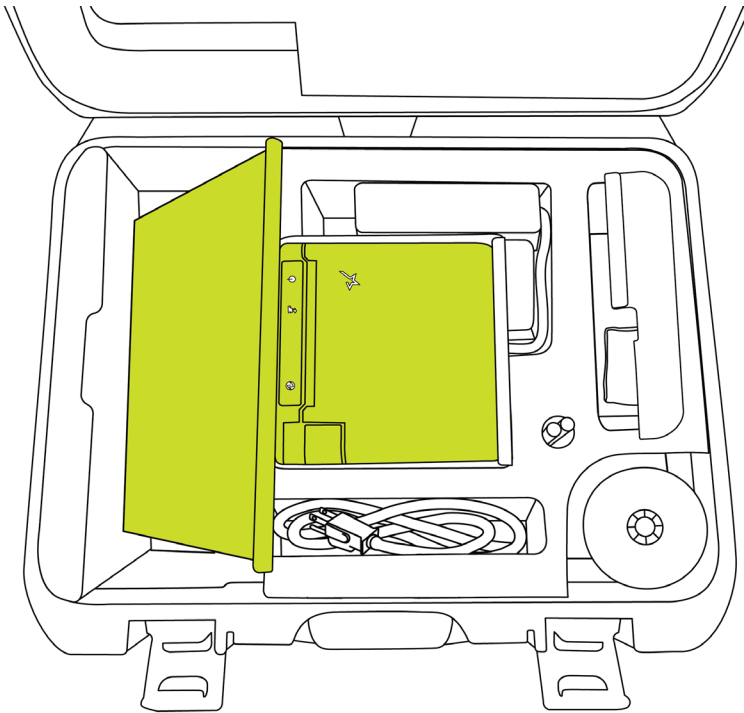

**5 PUT THE KIOSK IN THE GREEN CASE**

- A** Place the kiosk back into green case.
- B** Replace both foam inserts on top of the Poll Pad as indicated.

**6 PACK ANY REMAINING ACCESSORIES**

This may include any stylus, cleaning cloth, or printer paper.



# POLL PAD<sup>®</sup>

ELECTION DAY POLLWORKER GUIDE

SETUP | TROUBLESHOOTING | CLOSING