

# ACCESSORY STRUCTURES IN RESIDENTIAL ZONING DISTRICTS

RA, VR, R-1, R-2, R-4, R-10, R-15, PRD, or PUD

## SIZE OF STRUCTURE AND BUILDING PERMIT REQUIREMENTS

All accessory structures need building permits to verify location and structure size. Accessory structures below 256 square feet, and only one story are not required to meet the building code. Thus, no building plans need to be provided with the building permit. For a building permit application for a structure meeting the criteria above, you must provide two copies of the recorded plat of the property showing the proposed location of the structure and the distance from all property lines and existing dwellings. (Approximations of distances can be made when the structure will be over 50' from a property line)

[SEE SECTION 4 GENERAL REGULATIONS](#) & [SEE SECTION 3 DEFINITIONS](#) for Accessory structure, Yards, Setbacks, Building height, Infill

## HEIGHT OF ACCESSORY STRUCTURES (Section 4.10.3.4)

No accessory structure in a residential district shall exceed a height of twenty-four (24) feet.

(NOTE: In the RA district no accessory structure shall exceed a height of thirty-five (35) feet.)

## ACCESSORY STRUCTURES PERMITTED IN REQUIRED YARDS (SEE Table 1) (Section 4.11.2)

Accessory structures are authorized in required yards as follows:

a. *Front yards.* Accessory structures, including detached garages, are prohibited within the minimum front yard required by the applicable district regulations except as otherwise provided in subsection (c).

b. *Side and rear yards.* Accessory structures are permitted in side and rear yards, provided that they are erected no closer than five (5) feet from any side lot line in a non-infill development within the R-1, R-2, R-4, R-6, R-10, R-15, PRD, or PUD districts, and no closer than six (6) feet from any other side or rear property lines or, in the case of an alley or a shared driveway, no closer than three (3) feet to the edge of the easement or right-of-way of the alley or shared driveway except as otherwise provided in subsection (c).

### (SEE Diagrams 1 & 2)

The zoning administrator may authorize an accessory structure to be located closer to the edge of an alley easement or right-of-way if the county engineer determines that the proposed design incorporates features that assure public safety and welfare. In making the determination, the county engineer shall consider the provision of adequate access to required onsite parking and/or garages, unimpeded vehicular circulation along the alley, an adequate clear zone along the alley, and other safety issues deemed appropriate for the conditions.

c. *Accessory structures permitted in required yards.* The following accessory structures are permitted in required yards provided that they comply with the visibility clearance requirements of section 4.4:

1. Fences, including free-standing walls enclosing yards and other uncovered areas.
2. Freestanding mail and newspaper boxes.
3. Retaining walls.
4. Shelters for school children traveling to and from school.
5. Public telephone booths, provided that: (i) the telephones are equipped for emergency service to the public without prior payment; (ii) the zoning administrator determines that the location of the booth will not adversely affect the safety of the adjacent street; and (iii) the booth shall be subject to relocation at the expense of the owner, whenever relocation is determined by the zoning administrator to be reasonably necessary to protect the public health, safety and welfare or whenever relocation is necessary to accommodate the widening of the adjacent street.
6. Automated teller machines.

d. *Accessory structures located closer than three (3) feet to the primary structure.* Accessory structures for which any part is located closer than three (3) feet to any part of a primary structure shall comply with the minimum applicable yard requirements for a primary structure. (SEE Diagrams 1 & 2)

**Table 1: REQUIRED YARDS**

RESIDENTIAL ZONING DISTRICT	REQUIRED YARDS		
	FRONT YARD/SETBACK	SIDE YARD/SETBACK	REAR YARD/SETBACK
<a href="#">RA</a>	From existing public street ROW 75' From internal public street ROW or private street ROW 25'	25'	35'
<a href="#">VR</a>	25'	15'	20'
<a href="#">R-1</a>	<a href="#">See Section 4.19</a>	<a href="#">See Section 4.19</a>	<a href="#">See Section 4.19</a>
<a href="#">R-2</a>	<a href="#">See Section 4.19</a>	<a href="#">See Section 4.19</a>	<a href="#">See Section 4.19</a>
<a href="#">R-4</a>	<a href="#">See Section 4.19</a>	<a href="#">See Section 4.19</a>	<a href="#">See Section 4.19</a>
<a href="#">R-6</a>	<a href="#">See Section 4.19</a>	<a href="#">See Section 4.19</a>	<a href="#">See Section 4.19</a>
<a href="#">R-10</a>	<a href="#">See Section 4.19</a>	<a href="#">See Section 4.19</a>	<a href="#">See Section 4.19</a>
<a href="#">R-15</a>	<a href="#">See Section 4.19</a>	<a href="#">See Section 4.19</a>	<a href="#">See Section 4.19</a>
<a href="#">DCD, PRD or PUD</a>	<a href="#">CONTACT A ZONING PLANNER FOR SETBACKS</a>		

**Diagram 1: SETBACKS for NON-INFILL\***

R-1, R-2, R-4, R-10, R-15, PRD, or PUD

NOT TO SCALE

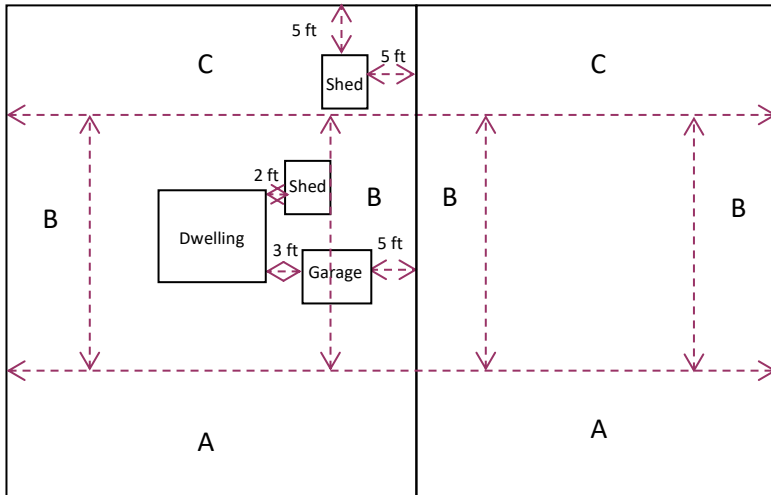

Street Right-of-way

**Diagram 2: SETBACKS for RA, VR, and INFILL**

R-1, R-2, R-4, R-10, R-15, PRD, or PUD

NOT TO SCALE

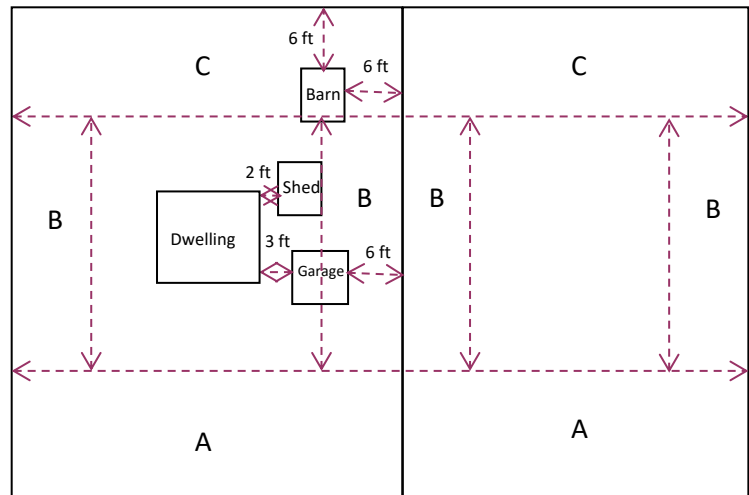

Street Right-of-way

A – Required Front Yard/Setback

B - Required Side Yard/Setback

C - Required Rear Yard/Setback

[SEE SECTION 3 DEFINITIONS](#) for Accessory structure, Yards, Setbacks, Building height, Infill (\* A parcel that does not meet the definition for Infill is considered Non-Infill) PLEASE VERIFY WITH A [ZONING PLANNER](#) before applying for a building permit.