

**Oven & Steamer  
Replacement Multiple  
Locations**

**Albemarle County Public  
Schools Charlottesville,  
Virginia**

**May 14, 2024**

**IFB# 2024-IFB-6050624**



**INVITATION FOR BIDS**  
 Oven & Steamer Replacement Multiple Locations  
 2024-IFB-6050624

**PROJECT MANUAL TABLE OF CONTENTS**

<b><u>BIDDING INFORMATION</u></b>		<u>Page No.</u>
Invitation for Bids		IFB-1
Bid Receipt and Bid Opening Procures (if needed)		
Instructions to Bidders		ITB-1 to ITB-9
Prebid Question Form		
Bid Form		BF-1 to BF-6
Certification of Crimes Against Children		1
Bid Receipt and Bid Opening Procedures		1
 <b><u>GENERAL CONDITIONS &amp; FORMS</u></b>		 <u>Page No.</u>
Construction Contract General Conditions		1 - 61
Supplemental General Conditions		1 - 2
Special Conditions		1 - 3
		 <u>AC Form #</u>
Contract Between Owner and Contractor		AC-9
Post Bid Modification		AC-9b
Standard Performance Bond		AC-10
Standard Labor and Material Payment Bond		AC-10.1
Construction Change Order		AC-11
Change Order Estimate (General Contractor)		GC-1
Change Order Estimate (Subcontractor)		SC-1
Change Order Estimate (Sub-subcontractor)		SS-1
Schedule of Values and Certificate for Payment		AC-12
Affidavit of Payment of Claims		AC-13
Architect/Engineer's Certificate of Substantial Completion		AC-13.1a
Architect/Engineer's Certificate of Completion		AC-13.1
Contractor's Certificate of Substantial Completion		AC-13.2a
Contractor's Certificate of Completion		AC-13.2
 <b><u>APPENDIX</u></b>		 <u>Page No.</u>
Appendix A: Code of Conduct		1 - 3
Appendix B: Agnor Hurt Elementary School Spec.		1 - 8
Appendix C: Baker Butler Elementary School Spec.		1 - 6
Appendix D: Brownsville Elementary School Spec.		1 - 6
Appendix E: Burley Middle School Spec.		1 - 3
Appendix F: Greer Elementary School Spec.		1 - 3
Appendix G: Journey Middle School Spec.		1 - 3
Appendix H: Lakeside Middle School Spec.		1 - 6
Appendix I: Monticello High School Spec.		1 - 3
Appendix J: Mountain View Elementary School Spec.		1 - 6
Appendix K: Scottsville Elementary School Spec.		1 - 3
Appendix L: Stone Robinson Elementary School Spec.		1 - 3

**NOTICE OF  
INVITATION FOR BIDS  
2024-IFB-6050624 – Oven & Steamer Replacement Multiple Locations**

Sealed bids are invited for the Oven & Steamer Replacement Multiple Locations.

The project is generally described as:

- 1. Agnor Hurt Elementary School – Appendix B**
  - a. Vendor to remove existing steamer and take to loading dock. Vendor to receive, deliver, uncrate and install new steamer and filter. Vendor to provide all final electrical, gas, water and drain connections.
  - b. Vendor to remove existing double deck convection ovens and take to loading dock. Vendor to receive, deliver, uncrate and install new double deck combi and filter. Vendor to provide all final electrical, water and drain connections.
  
- 2. Baker Butler Elementary School – Appendix C**
  - a. Vendor to remove existing double deck convection ovens and take to loading dock. Vendor to receive, deliver, uncrate and install new double deck combi and filter. Vendor to provide all final electrical, gas, water and drain connections.
  
- 3. Brownsville Elementary School – Appendix D**
  - a. Vendor to remove existing double deck convection ovens and take to place in the school requested. Vendor to receive, deliver, uncrate and install new double deck combi and filter. Vendor to provide all final electrical, water and drain connections.
  
- 4. Burley Middle School – Appendix E**
  - a. Vendor to remove old and take to loading dock or place in school where required, vendor to deliver new equipment, uncrate, set in place and make all gas and electric final connections and start up ovens.
  
- 5. Greer Elementary School – Appendix F**
  - a. Vendor to remove existing steamer and take to loading dock. Vendor to receive, deliver, uncrate and install new steamer and filter. Vendor to provide all final electrical, water and drain connections.
  
- 6. Journey Middle School – Appendix G**
  - a. Vendor to remove existing steamer and take to loading dock. Vendor to receive, deliver, uncrate and install new steamer and filter. Vendor to provide all final electrical, water and drain connections.
  
- 7. Lakeside Middle School – Appendix H**
  - a. Vendor to remove existing double deck convection ovens and take to loading dock or place within school requested. Vendor to receive, deliver, uncrate and install new double deck combi and filter. Vendor to provide all final electrical, gas, water and drain connections.
  
- 8. Monticello High School – Appendix I**
  - a. Vendor to remove existing steamer and take to loading dock or place in school requested. Vendor to receive, deliver, uncrate and install new steamer and filter. Vendor to provide all final electrical, gas, water and drain connections.
  
- 9. Mountain View Elementary School – Appendix J**
  - a. Vendor to remove existing double deck convection ovens and take to loading dock. Vendor to receive, deliver, uncrate and install new double deck combi and filter. Vendor to provide all final electrical, water and drain connections.

**10. Scottsville Elementary School – Appendix K**

- a. Vendor to remove existing steamer and take to loading dock. Vendor to receive, deliver, uncrate and install new steamer and filter. Vendor to provide all final electrical, water and drain connections.

**11. Stone Robinson Elementary School – Appendix L**

- a. Vendor to remove existing steamer and take to loading dock or place in school where requested. Vendor to receive, deliver, uncrate and install new steamer and filter. Vendor to provide all final electrical, water and drain connections.

Sealed bids will be received at the Albemarle County Procurement Office, Room 248, Albemarle County Office Building, 401 McIntire Road, Charlottesville, Virginia. The deadline for submitting bids is **2:00 P.M.**, as determined by the Purchasing Agent, on **Tuesday, June 4, 2024**. The bids will be opened publicly and read aloud immediately following the receipt of bids. If the County of Albemarle is closed for business at the time scheduled for bid opening, for whatever reason, sealed bids will be accepted and opened on the next scheduled business day, at the originally scheduled time.

The estimated construction cost range for this project is \$350K – \$500K A Bid Bond is required for any bid which exceeds \$100,000. The “Time for Completion” will be as detailed in the Bid Form.

Bids to be considered shall be received in a sealed envelope marked as follows: County of Albemarle, Procurement Office, Room 248, Albemarle County Office Building, 401 McIntire Road, Charlottesville, VA 22902 / Contract: **Ovens & Steamer Replacement Multiple Locations** / IFB No. **2024-IFB-6050624**

Procedures for submitting a bid, claiming an error, withdrawal of bids, and other pertinent information are contained in the Instructions to Bidders, which is part of the Invitation for Bids. Withdrawal due to error in bid shall be permitted in accord with Section 9 of the Instructions to Bidders and §2.2-4330A (i), Code of Virginia. The Owner reserves the right to reject any or all bids.

A In Person pre-bid conference will be held at Greer Elementary School at 2:00p.m. on May 23, 2024. Attendance will be optional for those submitting a bid.

The contract shall be awarded on a lump sum basis as follows: the Total Base Bid Amount

Contractor registration in accordance with Title 54.1, Chapter 11, of the Code of Virginia, is required. See the Instructions to Bidders for additional qualification requirements.

The Invitation for Bids for the above project, including the drawings and the specifications prepared by Lane Marketing Group and containing the information necessary for bidding, may be downloaded online from the Albemarle County Procurement website at

<https://www.albemarle.org/government/finance/procurement/solicitations>.

Please note that Bidders are responsible to check the Procurement web site and download any Addenda issued for this Bid.

The County of Albemarle does not discriminate on the basis of race, religion, color, sex, national origin, age or disability, or against faith-based organizations as defined under the Virginia Public Procurement Act on the basis of such organization’s religious or charitable character.

## INSTRUCTIONS TO BIDDERS

**The Invitation For Bids (IFB)** consists of the Notice, this Instructions to Bidders, the Bid Form, the Pre-Bid Question Form, the Construction Contract General Conditions, the Supplemental General Conditions (if any), the Special Conditions (if any), the Forms to be used, and the Scope of Work as described by the Plans and Specifications, other documents listed in the Specifications, and any addenda which may be issued, all of which request qualified bidders to submit competitive prices or bids for providing the described work on the project.

1. **CONDITIONS AT SITE OR STRUCTURE:** Bidders shall be responsible for ascertaining pertinent local conditions such as location, accessibility, general character of the site or building, and the character and extent of existing work within or adjacent to the site. Claims, as a result of failure to have done so, will not be considered by the Owner. See Section 7 of the General Conditions entitled “Conditions at Site.”
  
2. **EXPLANATIONS TO BIDDERS:** Bidders may not rely on any oral explanation in regard to the meaning of drawings and specifications or oral instructions given before the award of the contract. Discrepancies, omissions or doubts as to the meaning of drawings and specifications shall be communicated in writing to the Architect/Engineer for interpretation. Bidders must use the “Prebid Question Form” provided in the bid documents. Bidders must so act to assure that questions reach the Architect/Engineer at least seven (7) days prior to the time set for the receipt of bids to allow a sufficient time for an addendum to reach them before the submission of their bids. If an addendum is required for clarification or interpretation of the Bid Documents, the addendum will be issued not later than five (5) days prior to the date set for the receipt of bids except an addendum withdrawing the invitation for bid or one which includes postponement of the date set for the receipt of bids. Any interpretation made will be in the form of an addendum to the Invitation For Bids, which will be made available to all bidders, and its receipt shall be acknowledged, in writing, by the bidder on the Bid Form.
  
3. **TIME FOR COMPLETION:**
  - (a) “Time for Completion” shall be designated by the Owner on the Invitation for Bids or other pre-bid documents and shall mean the number of consecutive calendar days following the issuance of the Notice to Proceed which the Contractor has to substantially complete all Work required by the Contract. In some instances, the Time for Completion may be stated in the form of a Contract Completion Date based on a stipulated date of Notice to Proceed.

Unless otherwise specified, the Contractor shall achieve Final Completion within thirty (30) days after the date of Substantial Completion.
  - (b) When the Notice to Proceed is issued, it will state a Contract Completion Date, which has been set by the Owner based on date of the Notice to Proceed and the Time for Completion.
  - (c) The Contractor, in preparing and submitting his bid, is required to take into consideration normal weather conditions. No additional compensation will be paid to the Contractor because of adverse weather conditions; however, an extension of time for abnormal weather will be considered by the Owner as indicated in the General Conditions.

#### 4. PREPARATION AND SUBMISSION OF BIDS:

- (a) Bids shall be submitted on the forms furnished, or copies thereof, and shall be signed in ink. Erasures or other changes in a bid must be explained or noted over the signature of the bidder. Bids containing any conditions, omissions, unexplained erasures, alterations or items not called for in the proposal, or irregularities of any kind, may be rejected by the Owner as being incomplete or nonresponsive.
- (b) Each bid must give the complete legal name and full business address of the bidder and be signed by the bidder, or the bidder's authorized representative, with his usual signature. Bids by partnerships must be signed in the partnership name by one of the general partners of the partnership or an authorized representative, followed by the designation/title of the person signing. Bids by corporations must be signed with the legal name of the corporation followed by the name of the state in which it is incorporated and by the signature and title of the person authorized to bind it in this matter. The name of each person signing shall be typed or printed below the signature. A signature on a bid by a person who identifies his title as "President," "Secretary," "Agent" or other designation without disclosing the principal firm, shall be held to be the bid of the individual signing. When requested by the Owner, satisfactory evidence of the authority of the officer signing on behalf of the corporation shall be furnished. Trade or fictitious names may be referenced by using "t/a \_\_\_\_" but bids shall be in the legal name of the person or entity submitting the bid.
- (c) Bids with the bid guarantee shall be enclosed in a sealed envelope which shall be marked and addressed as indicated by the advertisement. If a contract is for one hundred twenty thousand dollars (\$120,000) or more, or if the total value of all construction, removal, repair or improvements undertaken by the bidder within any twelve-month period is seven hundred fifty thousand dollars (\$750,000) or more, the bidder is required under Title 54.1, Chapter 11, Section 1100, Code of Virginia, as amended, to be licensed in Virginia as a "Class A Contractor." If a contract is for ten thousand dollars (\$10,000) or more, but less than one hundred twenty thousand dollars (\$120,000), or if the total value of all construction, removal, repair or improvements undertaken by the bidder within any twelve-month period is one hundred fifty thousand dollars (\$150,000) or more, but less than seven hundred fifty thousand dollars (\$750,000), the bidder is required to be licensed in Virginia as a "Class B Contractor."

If the bidder is not properly licensed in Virginia at the time the bid is submitted, or if the bidder fails to provide this information on his bid or fails to promptly provide said Contractor license number to the Owner in writing when requested to do so after the opening of bids, he shall be deemed to be in violation of Section 54.1-1115 of the Code of Virginia, as amended, and his bid will not be considered.

- (d) The Board for Contractors has interpreted its regulations to mean "a licensed Contractor can bid on a contract which contains work outside his license classification(s) as long as he subcontracts those items for which he is not qualified to licensed contractors with the appropriate License Classification and the work of the second party is incidental to the contract." Therefore, the Owner may, as a part of determining whether the bidder is "responsible," require the apparent low bidder

to submit a listing of his subcontractors along with the license number and classification or specialty of each.

- (e) The bidder must also place its Employer Identification Number (SSN or FEIN) in the space provided on the Bid Form.
- (f) Every bidder organized as a stock or nonstock corporation, limited liability company, business trust, or limited partnership or registered as a registered limited liability partnership must be authorized to transact business in the Commonwealth as a domestic or foreign business entity if so required by Title 13.1 or Title 50 of the Code of Virginia, as amended, or as otherwise required by law. Any bidder organized or authorized to transact business in the Commonwealth pursuant to Title 13.1 or Title 50 must include in its bid the identification number issued to it by the State Corporation Commission. Any bidder that is not required to be authorized to transact business in the Commonwealth as a foreign business entity under Title 13.1 or Title 50 or as otherwise required by law shall include in its bid or proposal a statement describing why the bidder or offeror is not required to be so authorized. A bidder required to be authorized to transact business in Virginia that fails to provide the required information shall not receive an award unless a waiver of this requirement and of any administrative policies and procedures established to implement Section 2.2-4311.2 of the Code of Virginia, as amended, is granted by the Owner.

If awarded the Contract, the bidder shall not allow its existence to lapse or its certificate of authority or registration to transact business in the Commonwealth, if so required under Title 13.1 or Title 50, to be revoked or cancelled at any time during the term of the Contract. Doing so shall be deemed to be a violation of Section 2.2-4311.2 and the bidder understands and agrees that the Owner may void the Contract if the bidder fails to comply with this provision.

## 5. **BID GUARANTEE:**

- (a) Any bid (including the Total Base Bid plus all Additive Bid Items) which exceeds one hundred thousand dollars (\$100,000) shall be accompanied by a Bid Bond payable to the Owner as obligee in an amount equal to five percent (5%) of the amount of the bid. A Bid Bond may be required for projects having bids of less than one hundred thousand dollars (\$100,000) if such requirement is stated in the Notice of Invitation for Bids. The Bid Bond must be issued by a surety company which is legally authorized by the Virginia State Corporation Commission to do fidelity and surety business in the Commonwealth of Virginia. **The bid bond shall identify the name and address of an attorney-in-fact who is appointed to act on behalf of the surety. The attorney-in-fact shall affix to the bond a certified and current copy of the power of attorney.** Such Bid Bond shall guarantee that the bidder will not withdraw his bid during the period of sixty (60) days following the opening of bids; that if his bid is accepted, he will enter into a formal contract with the Owner in accordance with the Contract Between Owner and Contractor included as a part of the IFB Documents; that he will submit a properly executed and authorized Standard Performance Bond and Standard Labor and Material Payment Bond on the forms included in the IFB documents; and that in the event of the withdrawal of said bid within said period, or failure to enter into said contract and give said bonds within ten (10) days after he has received notice of acceptance of his bid, or other forfeiture under the Bid Bond, the bidder shall be liable to the Owner for the difference between the amount specified in said bid and such larger amount for which the Owner may contract with another party to perform the work covered by said bid, up to the amount of the bid guarantee.

This amount represents the damage to the Owner on account of the default of the bidder in any particular hereof. See §2.2-4336 of the Code of Virginia.

- (b) See §2.2-4338 of the Code of Virginia for provisions allowing alternative forms of bid security in lieu of a Bid Bond.
- (c) The Bid Bonds or other bid security will be returned to all except the three lowest bidders after the formal opening of bids. The remaining Bid Bonds or bid security will be returned to the bidders after the Owner and the accepted bidder have executed the Contract and the Performance Bond and the Payment Bond have been approved by the Owner.
- (d) If the required Contract and bonds have not been executed within sixty (60) days after the date of the opening of the bids, then the bond or other bid security of any bidder will be returned upon his request, provided he has not been notified of the acceptance of his bid prior to the date of such request.

## **6. WITHDRAWAL OR MODIFICATION OF BIDS:**

- (a) **WITHDRAWAL:** Bids may be withdrawn by written or telefaxed notice received from bidders prior to the deadline fixed for bid receipt. The bidder has sole responsibility to ensure that such notice is received by the Owner in the appropriate office designated in the Instructions to Bidders, and the Owner shall not be responsible for ensuring accurate or prompt delivery. A withdrawal must be signed by the person signing the sealed bid or by other individual(s) who is authorized to act on behalf of the bidder. Such authorization must be provided in writing at the time of withdrawal, and stated on the face of the withdrawal notice. Withdrawn bids may be resubmitted by the bidder up to the deadline fixed for bid receipt.
- (b) **MODIFICATION:** Bids may be modified only in the following manner. E-mail or telefaxed modifications are not acceptable. All modifications must be signed by the person signing the sealed bid or by an individual(s) who is authorized by him/her on the face of the bid. Written modifications may only be made on the bid form itself. Written modifications must be signed by the person making the modification. The modification must state specifically what is to be modified and by what amount or it must state the item to be modified and what the corrected amount should be. (e.g. “Deduct \$25,000 from Part A and from the Total Base Bid Amount”; or “Add \$23,456 to the Total Base Bid Amount”; or “Deduct \$15,650 from the Additive # 2 amount”). A modification to “Deduct \$25,000 from Part A” will only be applied to Part A and not to the Total Base Bid Amount). Unless otherwise specified by the Bidder in the modification, the modification will be applied to the TOTAL BASE BID AMOUNT shown on the Bid Form (e.g. a modification stating only “Deduct \$25,000” which is properly signed will be deducted from the Total Base Bid Amount shown on the Bid Form).

## **7. RECEIPT OF BIDS:**

- (a) Bids will be received at or before the date and the hour and at the place stipulated in the Invitation for Bids as may be modified by subsequent Addenda.
- (b) It is the responsibility of the bidder to assure that his bid and any bid modifications are delivered to the place designated for receipt of bids by the date and hour (deadline) set for receipt of bids.

Therefore, it is the bidder's responsibility to take into account all factors which may impact on its bid deliverer/courier's ability to deliver the bid and to implement whatever actions are necessary to have the bid delivered to the proper bid receipt location prior to the bid receipt deadline. No bids or bid modifications submitted or offered after the date and hour designated for receipt of bids will be accepted or considered.

- (c) The Purchasing Agent is the Owner's representative designated to receive bids at the time and place noted in the IFB and to open the bids received at the appointed time.
- (d) The official time used for the receipt of responses is determined by reference to the clock designated by the Purchasing Agent. The Purchasing Agent shall determine when the Bid Receipt Deadline has arrived and shall announce that the Deadline has arrived and that no further bids or bid modifications will be accepted. All bids and bid modifications in the possession of the Purchasing Agent and his assistants at the time the announcement is completed are deemed to be timely, whether or not the bid envelope has been physically date/time stamped or otherwise marked by the time the Purchasing Agent makes the deadline announcement.

## 8. **OPENING OF BIDS:**

- (a) Bids will be opened at the time and place stated in the Invitation for Bids or as modified by subsequent Addenda, and their contents publicly announced. The Purchasing Agent shall decide when the specified time for bid opening has arrived. No responsibility will be attached to any officer or agent for the premature opening of a bid not properly addressed and identified.
- (b) The provisions of §2.2-4342 of the Code of Virginia shall be applicable to the inspections of bids received.

9. **ERRORS IN BIDS:** A bidder may withdraw his bid from consideration if the price bid was substantially lower than the other bids due solely to a mistake therein, provided the bid was submitted in good faith, and the mistake was a clerical mistake as opposed to a judgment mistake, and was actually due to an unintentional arithmetic error or an unintentional omission of a quantity of work, labor or material made directly in the compilation of a bid, which unintentional arithmetic error or unintentional omission can be clearly shown by objective evidence drawn from inspection of original work papers, documents and materials used in the preparation of the bid sought to be withdrawn. The bidder shall give notice of a claim to withdraw a bid, in writing, and submit his original work papers, documents and materials used in the preparation of his bid, to the Purchasing Agent within two business days after the conclusion of the opening of bids. §2.2-4330(B)(1) of the Code of Virginia.

Failure of a bidder to give notice and submit his original work papers, documents and materials used in the preparation of his bid on or before the time, date and place required shall constitute a waiver by that bidder of his right to withdraw his bid due to a mistake.

No bid may be withdrawn under this section when the result would be the awarding of the Contract on another bid of the same bidder or of another bidder in which the ownership of the withdrawing bidder is more than five percent (5%).

No bidder who is permitted to withdraw a bid shall, for compensation, supply any material or labor to or perform any subcontract or other work agreement for the person or firm to whom the Contract is awarded

or otherwise benefit, directly or indirectly, from the performance of the project for which the withdrawn bid was submitted. The person or firm to whom the Contract was awarded and the withdrawing bidder are jointly liable to the Owner in an amount equal to any compensation paid to or for the benefit of the withdrawing bidder without such approval.

If a bid is withdrawn under authority of this section, the lowest remaining bid shall be deemed to be the low bidder on the project.

**10. REJECTION OF BIDS:** The Owner reserves the right to cancel the Invitation for Bids, to reject any and all bids at its sole discretion when such rejection is in the interest of the Owner, or to reject the bid of any bidder who is determined to be not responsive or not responsible. See §2.2-4319, Code of Virginia.

**11. DETERMINATION OF RESPONSIBILITY:**

Each bidder shall be prepared, if so requested by the Owner, to present evidence of his experience, qualifications and financial ability to carry out the terms of the Contract.

Prior to award of the Contract, an evaluation will be made to determine if the low bidder has the capability, in all respects, to perform fully the contract requirements and the moral and business integrity and reliability which will assure good faith performance, and who has been prequalified, if required. Factors to be evaluated may include, but are not limited to:

- (a) sufficient financial ability to perform the contract as evidenced by the bidder's ability to obtain payment and performance bonds from an acceptable surety;
- (b) appropriate experience to perform the Work described in the bid documents;
- (c) any judgments entered against the bidder, or any officers, directors, partners or owners for breach of a contract for construction;
- (d) any substantial noncompliance with the terms and conditions of prior construction contracts with a public body without good cause where the substantial noncompliance is documented; or
- (e) a conviction of the bidder or any officer, director, partner, project manager, procurement manager, chief financial officer, or owner in the last five years of a crime relating to governmental or nongovernmental construction or contracting;
- (f) any current debarment of the contractor, any officer, director or owner, from bidding or contracting by any public body of any state, any state agency, or any agency of the federal government.

The Owner reserves the right to disqualify or refuse to accept the bid of any bidder who has been convicted, or entered a plea of guilty or nolo contendere, in any federal or state court to any charge involving any unlawful, corrupt or collusive practice involving a public contract whether federal, state, or local, or who has been determined in any judicial proceeding to have violated any antitrust, bid-rigging or collusive practice statute in connection with any public contract, or against whom such formal criminal prosecution or other judicial proceeding has been initiated.

A bidder who, despite being the apparent low bidder, is determined not to be a responsible bidder shall be notified in writing in conformance with the procedures in §2.2-4359 of the Code of Virginia.

## 12. AWARD OF CONTRACT:

- (a) **Basis for Contract Award:** The Contract, if awarded, will be awarded to the lowest responsive and responsible bidder, if any, provided his bid is reasonable and it is in the best interest of the Owner to accept it and subject to the Owner's right to reject any and all bids and to waive informality in the bids and in the bidding. The Bid Form may contain a multi-part Base Bid and may contain Additive Bid Items. Determination of the lowest responsive bidder, if any, will be based on the Total Base Bid amount entered on the Bid Form including any properly submitted bid modifications plus as many Additive Bid Items taken in sequence as the Owner in its discretion chooses to Award. Where the sum of the values entered in the multiple parts do not agree with the Total Base Bid amount, the Total Base Bid amount entered on the Bid Form, including any properly submitted bid modifications, shall take precedence. In the event that the Total Base Bid from the lowest responsible bidder exceeds available funds, the Owner may negotiate the Total Base Bid amount with the apparent low bidder to obtain a contract price within available funds, pursuant to §2.2-4318 of the Code of Virginia and Section 12(c) herein.
- (b) **Informalities:** The Owner reserves the right to waive any informality in the bids when such waiver is in the interest of the Owner.
- (c) **Negotiation With Lowest Responsible Bidder:** If award of a contract to the lowest responsive and responsible bidder is precluded because of limitations on available funds, under the provisions of §2.2-4318 of the Code of Virginia (the Public Procurement Act), the Owner reserves the right to negotiate the Total Base Bid amount with the lowest responsive, responsible bidder to obtain a contract price within the available funds. This may involve changes in either the features or scope of the work included in the Base Bid. Such negotiations with the apparent low bidder may include reducing the quantity, quality, or other cost saving mechanisms involving items in the Total Base Bid. The Owner shall notify the lowest responsive and responsible bidder that such a situation exists and the Owner and bidder shall then conduct their negotiations in person, by mail, by telephone or by any means they find convenient. If an acceptable contract can be negotiated, the changes to the Invitation for Bid documents agreed upon in the negotiations shall be summarized in a "Post Bid Modification" and included in the contract. If an acceptable contract cannot be negotiated, the Owner shall terminate negotiations and reject all bids.
- (d) **Notice of Intent to Award or Notice of Award:** The Notice of Award or the Notice of Intent to Award will be posted on the Albemarle County Purchasing Office web site with the Invitation for Bid procurement documents ([www.albemarle.org/purchasing](http://www.albemarle.org/purchasing)). Any bidder or offeror who desires to protest the award or decision to award a contract shall submit the protest in writing to the Albemarle County Purchasing Agent no later than ten days after the posting of the Notice of Award or Notice of Intent to Award, whichever comes first (§ 2.2-4360).

13. **CONTRACT SECURITY:** For contracts of more than \$100,000, the Standard Performance Bond (Form AC-10) and the Standard Labor and Material Payment Bond (Form AC-10.1) shall be required, as specified in the Invitation for Bids documents. See the General Conditions and §2.2-4337 and §2.2-4338 of the Code of Virginia. The Owner reserves the right to require such bonds for contracts less than \$100,000. If the Owner so elects, the requirement shall be set forth in the Invitation for Bids. **The bonds shall identify the name and address of an attorney-in-fact who is appointed to act on behalf of the surety within the Commonwealth of Virginia. The attorney-in-fact shall affix to the bond a certified and current copy of the power of attorney.**

14. **CERTIFICATION:** The bidder, by his signature on the Bid Form, certifies that neither his organization nor any of its officers, directors, partners or owners is currently barred from bidding on contracts by the Commonwealth of Virginia, or any public body or agency of another state, or any agency of the federal government. See the statement “Disqualification of Contractors” in the Bid Form.
15. **ETHICS IN PUBLIC CONTRACTING:** The provisions, requirements and prohibitions as contained in Chapter 43, Article 6, §2.2-4367 et seq, Code of Virginia, pertaining to bidders, offerers, contractors, and subcontractors are applicable to this project.
16. **BUILDING PERMITS:** The Virginia Uniform Statewide Building Code shall apply to the Work and shall be administered by the local Building Official. The Building Permit will be obtained by the Contractor and paid for by the Owner. All other permits, local license fees, business fees, taxes, or similar assessments shall be obtained and paid for by the Contractor. See Section 25 of the General Conditions for utility connection fees and services.
17. **MINORITY UTILIZATION:** The County of Albemarle, Virginia, encourages the participation of minority businesses in public procurement activities. Towards that end, the Owner encourages firms to provide for the participation of minority owned businesses through partnerships, joint ventures, subcontracts, and other contractual opportunities.
18. **BID DOCUMENTS:** Bid Documents are the property of the Owner and are available electronically through the Albemarle County Purchasing Office web site at [www.albemarle.org/purchasing](http://www.albemarle.org/purchasing). Bidders are responsible to check the Purchasing web site and download any Addenda issued for the bid. A deposit is not required for downloading of electronic documents through the web site. The bidder is responsible for the cost of printing any contract documents necessary for bidding. If awarded a contract, the Owner will provide the contractor with two sets of contract documents (i.e. full sized drawings and specifications) for use in the field and the contractor will be responsible for the cost of printing any additional contract documents that may be needed.
19. **GENERAL CONDITIONS:** The County of Albemarle Construction Contract General Conditions are incorporated in the bid documents. If the General Conditions are incorporated by reference, the bidder may obtain a copy of the current edition of the Construction Contract General Conditions at no cost by request to the County of Albemarle, Facilities & Environmental Services - Project Management Division, 401 McIntire Road, Charlottesville, Virginia 22902 (434-872-4501).
20. **PREBID CONFERENCE:** See the Invitation for Bids for requirements for a prebid conference and whether such conference is mandatory or optional.
21. **INSPECTION OF BID DOCUMENTS:** Copies of the Invitation for Bids documents including Plans and Specifications will, upon request, be made available for inspection at the Albemarle County Facilities & Environmental Services Department - Project Management Division, or the A/E’s office.
22. **DRUG-FREE WORKPLACE REQUIRED:** Bidders are reminded that §2.2-4312 of the Code of Virginia requires that during the performance of the contract resulting from this solicitation, the contractor agrees to (i) provide a drug-free workplace for the contractor’s employees; (ii) post in conspicuous places, available to employees and applicants for employment, a statement notifying employees that the unlawful manufacture, sale, distribution, dispensation, possession, or use of a controlled substance or marijuana is

prohibited in the contractor's workplace and specifying the actions that will be taken against employees for violations of such prohibition; (iii) state in all solicitations or advertisements for employees placed by or on behalf of the contractor that the contractor maintains a drug-free workplace; and (iv) include the provisions of the foregoing clauses in every subcontract or purchase order of over \$10,000, so that the provisions will be binding upon each subcontractor or vendor.

For the purposes of this section, "drug-free workplace" means a site for the performance of work done in connection with a specific contract awarded to a contractor in accordance with this solicitation, the employees of whom are prohibited from engaging in the unlawful manufacture, sale, distribution, dispensation, possession or use of any controlled substance or marijuana during the performance of the contract.

- 23. CERTIFICATION OF CRIMES AGAINST CHILDREN:** Pursuant to Virginia Code §22.1-296.1(C), as a condition of awarding a contract for the provision of services that require the contractor or his employees to have direct contact with students on school property during regular school hours or during school-sponsored activities, the School Board requires the contractor to provide certification that all persons who will provide such services have not been convicted of a felony or any offense involving the sexual molestation or physical or sexual abuse or rape of a child. Any person making a materially false statement regarding any such offense shall be guilty of a Class 1 misdemeanor and, upon conviction, the fact of such conviction shall be grounds for the revocation of the contract to provide such services and, when relevant, the revocation of any license required to provide such services. This requirement does not apply to a contractor or his employees providing services to the School Board in an emergency or exceptional situation, such as when student health or safety is endangered or when repairs are needed on an urgent basis to ensure that school facilities are safe and habitable, when it is reasonably anticipated that the contractor or his employees will have no direct contact with students.

**PREBID QUESTION FORM**

(Use separate form for each question submitted.)

**DATE:** \_\_\_\_\_

**PROJECT: Oven & Steamer Replacement Multiple Locations  
2024-IFB-6050624**

The following question concerns Drawing Sheet (number)\_\_\_\_\_:

\_\_\_\_\_  
\_\_\_\_\_  
\_\_\_\_\_  
\_\_\_\_\_  
\_\_\_\_\_

The following question concerns Specifications Section (number)\_\_\_\_\_, page \_\_\_\_\_, paragraph \_\_\_\_\_:

\_\_\_\_\_  
\_\_\_\_\_  
\_\_\_\_\_  
\_\_\_\_\_  
\_\_\_\_\_

All responses to questions will be made by Addendum.

Questions submitted by: \_\_\_\_\_  
Name Organization

Email Form To: County of Albemarle Purchasing – Andy Neilson – [aneilson@albemarle.org](mailto:aneilson@albemarle.org)  
County of Albemarle Project Manager – April Nelson - [anewton@k12albemarle.org](mailto:anewton@k12albemarle.org)

**BID FORM**

DATE: \_\_\_\_\_

**PROJECT TITLE: Oven & Steamer Replacement Multiple Locations**  
**IFB No. 2024-IFB-6050624**

TO: County of Albemarle, Virginia, and/or  
The School Board of Albemarle County, Virginia  
Office of Procurement – Room 248  
Albemarle County Office Building  
401 McIntire Road  
Charlottesville, VA 22902

In compliance with and subject to your Invitation for Bids and the documents therein specified, all of which are incorporated herein by reference, the undersigned bidder proposes to furnish all labor, equipment, and materials and perform all work necessary for construction of this project, in accordance with the Plans and Specifications dated May 14, 2024, and the Addenda noted below, for the consideration of the following amount:

**BASE BID AMOUNT = \_\_\_\_\_ Dollars (\$ \_\_\_\_\_ )**

(Amount shall be shown in both words and figures. In case of discrepancy, the amount shown in words shall govern.)

Contract award will be based on the **TOTAL BASE BID AMOUNT shown above** (including any properly submitted bid modifications)

The undersigned understands that time is of the essence and agrees that the date for Substantial Completion of the entire project shall be on or before **August 9, 2024** based on a Notice authorizing Work to proceed on or before **July 5, 2024** with construction to begin onsite **July 8, 2024** and Final Completion shall be achieved within 30 consecutive calendar days after the date of Substantial Completion as determined by the A/E.

Acknowledgment is made of receipt of the following Addenda:

\_\_\_\_\_  
\_\_\_\_\_

If notice of acceptance of this bid is given to the undersigned within 60 days after the date of opening of bids, or any time thereafter before this bid is withdrawn, the undersigned will execute and deliver a contract in the prescribed form (County of Albemarle Contract Between Owner and Contractor, Form AC-9) within 10 days after the contract has been presented to him for signature. The required payment and performance bonds, on the forms prescribed, shall be delivered to the owner along with the signed Contract.

Immigration Reform and Control Act of 1986: The undersigned certifies that it does not and will not during the performance of the Contract for this project violate the provisions of the Federal Immigration Reform and Control Act of 1986, which prohibits employment of illegal aliens.

**DISQUALIFICATION OF CONTRACTORS:** By signing this bid or proposal, the undersigned certifies that this Bidder or any officer, director, partner or owner is not currently barred from bidding on contracts by any Agency of the Commonwealth of Virginia, or any public body or agency of another state, or any agency of the federal government, nor is this Bidder a subsidiary or affiliate of any firm/corporation that is currently barred from bidding on contracts by any of the same. We have attached an explanation of any previous disbarment(s) and copies of notice(s) of reinstatement(s).

**CERTIFICATION OF NO COLLUSION:** The undersigned does hereby certify in connection with the procurement and bid to which this Certification of No Collusion is incorporated that:

This bid is not the result of, or affected by, any act of collusion with another person engaged in the same line of business or commerce; nor is this bid the result of, or affected by, any act of fraud punishable under Article 1.1 of Chapter 12 of Title 18.2 of the Code of Virginia, 1950, as amended (18.2-498.1 et seq.).

The undersigned declares that they are fully authorized to sign the proposal on behalf of the firm listed and to all conditions and provisions thereof. The firm name given below is the true and complete name of the bidder and the bidder is legally qualified and licensed by the Commonwealth of Virginia, Department of Commerce, State Board for Contractors, to perform all Work included in the scope of the Contract.

Virginia License No. \_\_\_\_\_

Bidder \_\_\_\_\_  
(Name of Firm)

Contractor Class \_\_\_\_\_

By \_\_\_\_\_  
(Signature)

Valid Until \_\_\_\_\_

\_\_\_\_\_  
(Typed Name)

FEIN/SSN: \_\_\_\_\_

Title \_\_\_\_\_

If Partnership (List Partner's Names)

\_\_\_\_\_  
\_\_\_\_\_

If Corporation, affix Corporate Seal & list  
State of Incorporation

State: \_\_\_\_\_  
(Affix Seal)

Business Address:

\_\_\_\_\_  
\_\_\_\_\_  
\_\_\_\_\_  
\_\_\_\_\_

Telephone No.: \_\_\_\_\_

Fax No.: \_\_\_\_\_

Email: \_\_\_\_\_

# STATE CORPORATION COMMISSION & REGISTERED AGENT FORM

## Virginia State Corporation Commission (SCC) registration information.

**Code of Virginia § 13.1-757. A foreign corporation may not transact business in the Commonwealth until it obtains a certificate of authority from the Commission.**

**The bidder:**

<input type="checkbox"/>	is a corporation or other business entity with the following Virginia SCC identification number: _____ <b>-OR-</b>
<input type="checkbox"/>	is not a corporation, limited liability company, limited partnership, registered limited liability partnership, or business trust <b>-OR-</b>
<input type="checkbox"/>	<p>is not required to obtain a certificate of authority from the Virginia SCC, pursuant to <i>Virginia Code</i> § 13.1-757(B) because its sole contact(s) with the Commonwealth consist(s) of:</p> <ol style="list-style-type: none"> <li>1. <input type="checkbox"/> Maintaining, defending, or settling any proceeding;</li> <li>2. <input type="checkbox"/> Holding meetings of the board of directors or shareholders or carrying on other activities concerning internal corporate affairs;</li> <li>3. <input type="checkbox"/> Maintaining bank accounts;</li> <li>4. <input type="checkbox"/> Maintaining offices or agencies for the transfer, exchange, and registration of the corporation's own securities or maintaining trustees or depositories with respect to those securities;</li> <li>5. <input type="checkbox"/> Selling through independent contractors;</li> <li>6. <input type="checkbox"/> Soliciting or obtaining orders, whether by mail or through employees or agents or otherwise, if the orders require acceptance outside this Commonwealth before they become contracts;</li> <li>7. <input type="checkbox"/> Creating or acquiring indebtedness, deeds of trust, and security interests in real or personal property;</li> <li>8. <input type="checkbox"/> Securing or collecting debts or enforcing deeds of trust and security interests in property securing the debts;</li> <li>9. <input type="checkbox"/> Owning, without more, real or personal property;</li> <li>10. <input type="checkbox"/> Conducting an isolated transaction that is completed within 30 days and that is not one in the course of repeated transactions of a like nature;</li> <li>11. <input type="checkbox"/> For a period of less than 90 consecutive days, producing, directing, filming, crewing or acting in motion picture feature films, television series or commercials, or promotional films which are sent outside of the Commonwealth for processing, editing, marketing and distribution. The term "transacting business" as used in this subsection shall have no effect on personal jurisdiction under § 8.01-328.1; or</li> <li>12. <input type="checkbox"/> Serving, without more, as a general partner of, or as a partner in a partnership which is a general partner of, a domestic or foreign limited partnership that does not otherwise transact business in the Commonwealth.</li> <li>13. <input type="checkbox"/> Transacting business in interstate commerce.</li> </ol>
<input type="checkbox"/>	is an out-of-state business entity that is including with this bid <b><u>an opinion of legal counsel</u></b> which accurately and completely discloses the undersigned bidder's current contacts with Virginia and describes why those contacts do not constitute the transaction of business in Virginia within the meaning of § 13.1-757 or other similar provisions in Titles 13.1 or 50 of the Code of Virginia. <b>Attach opinion of legal counsel to this form.</b>

**Registered Agent Information**

Please specify the Registered Agent who will accept service of process on your behalf.

Agent Name: \_\_\_\_\_

Physical Address (no Post Office Boxes):

\_\_\_\_\_  
\_\_\_\_\_

I certify the accuracy of this information.

Signed: \_\_\_\_\_ Title: \_\_\_\_\_ Date: \_\_\_\_\_

# OFFEROR DATA SHEET

Note: The following information is required as part of your response to this solicitation. Failure to complete and provide this sheet may result in finding your bid nonresponsive.

1. **Qualification:** The vendor must have the capability and capacity in all respects to satisfy fully all of the contractual requirements.

2. **Vendor's Primary Contact:**

Name: \_\_\_\_\_ Phone: \_\_\_\_\_

3. **Years in Business:** Indicate the length of time you have been in business providing this type of good or service:

\_\_\_\_\_ Years \_\_\_\_\_ Months

4. **Vendor Information:**

FIN or FEI Number: \_\_\_\_\_ If Company, Corporation, or Partnership

5. Indicate below a listing of at least four (4) recent projects, either educational or governmental, that your company has successfully completed with similar scope, cost and complexity, include the date of services and the name, address, and email address, and telephone number of the point of contact.

A.	Company: _____	Contact: _____
	Phone: _____	Email: _____
	Dates of Service: _____	\$ Value: _____

B.	Company: _____	Contact: _____
	Phone: _____	Email: _____
	Dates of Service: _____	\$ Value: _____

C.	Company: _____	Contact: _____
	Phone: _____	Email: _____
	Dates of Service: _____	\$ Value: _____

D.	Company: _____	Contact: _____
	Phone: _____	Email: _____
	Dates of Service: _____	\$ Value: _____

I certify the accuracy of this information.

Signed: \_\_\_\_\_ Title: \_\_\_\_\_ Date: \_\_\_\_\_

**CERTIFICATION OF CRIMES AGAINST CHILDREN  
AND ACTS OF MORAL TURPITUDE**

Contractor acknowledges that the implementation of this contract requires Contractor, Contractor's employees and/or subcontractors to have direct contact with Albemarle County Public Schools' students. Therefore, Contractor hereby certifies that neither Contractor nor, to the best of Contractor's knowledge, its employees and/or subcontractors have been convicted of a felony or any offense involving the sexual molestation or physical or sexual abuse or rape of a child.

Contractor further certifies and shall indicate below whether Contractor and, to the best of Contractor's knowledge, its employees and/or its subcontractors, who will have direct contact with Albemarle County Public School students, have been convicted of a crime of moral turpitude. Crimes of "moral turpitude" are those crimes involving lying, cheating or stealing.

For the purposes of this certification, "direct contact with students" means being in the presence of students during regular school hours or during school sponsored activities.

Contractor understands that, pursuant to Code of Virginia §22.1-296.1(C), making a materially false statement regarding offenses which are required to be included in the certification referenced above is a Class 1 misdemeanor and, upon conviction, the fact of such conviction shall be grounds for the revocation of the contract to provide such services and, when relevant, the revocation of any license required to provide such services. Albemarle County Public Schools shall not be liable for materially false statements regarding the certifications required under this Contract.

.....

Have you or, to the best of your knowledge, any of your employees and/or subcontractors who will have direct contact with students been convicted of a crime of moral turpitude?

- NO
- YES (please explain)

\_\_\_\_\_

\_\_\_\_\_

\_\_\_\_\_

\_\_\_\_\_  
**Contractor**

\_\_\_\_\_  
**Date**

**By:** \_\_\_\_\_

**Title:** \_\_\_\_\_



**Bid Receipt and Bid Reading Procedures**  
**May 14, 2024**  
**2024-IFB-6050624 – Oven & Steamer**  
**Replacement Multiple Locations**

The following Albemarle County Purchasing Procedures shall be in effect:

1. Paper bids shall be prepared as usual and shall be delivered to the County Office Building at 401 McIntire Road, Charlottesville, VA 22902. Bids will be received in a secure manner and will be stored in such manner as to keep them in a secure status.
2. A secure lock box will be available, at the exterior of the County Office Building, at the front Visitors Entrance, and will be labeled **Vendor/Contractor Bids or Proposals Only**. Bids shall be placed in this box, prior to the established due date and time for each solicitation. It is the Offeror's responsibility to ensure that bids are received prior to the established bid due date and time.
3. Bids will be received in the lockbox until **2:00 pm ET on Tuesday, June 4, 2024**. Any further bids received will be ruled as late bids and will be retained un-opened. Late bids will not be considered. If you have any difficulty utilizing the lockbox please call the Purchasing Office, at 434- 296-5854.
4. Bid readings will be held at 2:30 pm on **Tuesday, June 4, 2024**. At the appointed time as noted below, the bids will be virtually opened and read aloud by Purchasing personnel. Public attendance at the Bid Reading will be by virtual attendance through MS Teams Meeting.
5. The bids shall be examined for conformance of all requirements of the solicitation including a signature, acknowledgement of addenda, and presence of a bid bond, when required. At the conclusion of the reading of the bids, Purchasing staff will complete the due diligence to examine bids for determination of complete responsiveness and vendor responsibility and additional information, including the bid tabulation, will be provided as it becomes available.
6. On **Tuesday, June 4, 2024 at 2:30 pm ET**, the Virtual Bid Reading may be attended through the following MS Teams Meeting link:

## **Microsoft Teams** [Need help?](#)

### [Join the meeting now](#)

**Meeting ID: 255 993 018 327**

**Passcode: QxmU4k**

**COUNTY OF ALBEMARLE**



**CONSTRUCTION CONTRACT GENERAL CONDITIONS**

**TABLE OF CONTENTS**

1. DEFINITIONS ..... 3

2. CONTRACT DOCUMENTS ..... 7

3. LAWS, REGULATIONS AND PERMITS ..... 8

4. NONDISCRIMINATION ..... 10

5. PROHIBITION OF ALCOHOL AND OTHER DRUGS ..... 11

6. TIME FOR COMPLETION ..... 11

7. CONDITIONS AT SITE..... 13

8. CONTRACT SECURITY ..... 14

9. SUBCONTRACTS ..... 14

10. SEPARATE CONTRACTS..... 15

11. CONTRACTOR’S AND SUBCONTRACTOR’S INSURANCE ..... 16

12. BUILDER’S RISK INSURANCE..... 19

13. TAXES, FEES AND ASSESSMENTS ..... 20

14. PATENTS ..... 20

15. ARCHITECT/ENGINEER’S STATUS..... 20

16. INSPECTION ..... 22

17. PROJECT MANAGEMENT AND SUPERVISION BY CONTRACTOR..... 24

18. CONSTRUCTION SUPERVISION, METHODS AND PROCEDURES ..... 24

19. SCHEDULE OF THE WORK..... 25

20. SCHEDULE OF VALUES AND CERTIFICATE FOR PAYMENT..... 29

21. ACCESS TO WORK..... 30

22. SURVEYS AND LAYOUT ..... 30

23. PLANS AND SPECIFICATIONS..... 31

24. SUBMITTALS..... 32

25. FEES, SERVICES AND FACILITIES..... 34

26. EQUALS ..... 35

27. AVAILABILITY OF MATERIALS ..... 35

28. CONTRACTOR’S TITLE TO MATERIALS..... 36

29. STANDARDS FOR MATERIALS INSTALLATION & WORKMANSHIP ..... 36

30. WARRANTY OF MATERIALS AND WORKMANSHIP ..... 38

31. USE OF SITE AND REMOVAL OF DEBRIS ..... 38

32. TEMPORARY ROADS..... 39

33. SIGNS ..... 39

34. PROTECTION OF PERSONS AND PROPERTY ..... 39

35. CLIMATIC CONDITIONS ..... 40

36. PAYMENTS TO CONTRACTOR..... 40

37. PAYMENTS BY CONTRACTOR (§2.2-4354, Code of Virginia) ..... 44

38. CHANGES IN THE WORK..... 444

39. CONTRACTOR’S RIGHT TO STOP WORK OR TERMINATE THE CONTRACT..... 50

40. OWNER’S RIGHT TO STOP WORK OR TERMINATE THE CONTRACT FOR CAUSE .... 500

41. TERMINATION BY OWNER FOR CONVENIENCE..... 511

42. DAMAGES FOR DELAYS; EXTENSION OF TIME ..... 52

43. INSPECTION FOR SUBSTANTIAL COMPLETION & FINAL COMPLETION ..... 544

44. GUARANTEE OF WORK ..... 555

45. ASSIGNMENTS OF CONTRACTUAL OBLIGATIONS ..... 58

46. CONTRACTUAL DISPUTES (§2.2-4363, Code of Virginia) ..... 58

47. ASBESTOS..... 58

48. TRAINING, OPERATION AND MAINTENANCE OF EQUIPMENT..... 59

49. PROJECT MEETINGS..... 59

## 1. DEFINITIONS

Whenever used in these Construction Contract General Conditions (“General Conditions”) or in the Contract Documents, the following terms have the meanings indicated, which are applicable to both the singular and plural and the male and female gender thereof:

**Architect, Engineer, Architect/Engineer or A/E:** The term used to designate the Architect and/or the Engineer that contracts with the Owner to provide the Architectural and Engineering services for the Project. The A/E is a separate contractor and not an agent of the Owner. The term includes any associates or consultants employed by the A/E to assist in providing the A/E services.

**Beneficial Occupancy:** The condition after Substantial Completion but prior to Final Completion of the Project at which time the Project, or portion thereof, is sufficiently complete and systems operational such that the Owner could, after obtaining necessary approvals and certificates, occupy and utilize the space for its intended use. Guarantees and warranties applicable to that portion of the Work begin on the date the Owner accepts the Project, or a portion thereof, for such Beneficial Occupancy, unless otherwise specified in the Supplemental General Conditions or by separate agreement.

**Building Permit:** See “Permit” below.

**Change Order:** A document (Form AC-11) issued on or after the effective date of the Contract Between Owner and Contractor (Form AC-9) which is agreed to by the Contractor and approved by the Owner, and which authorizes an addition, deletion or revision in the Work, including any adjustment in the Contract Price and/or the Contract Completion Date. A Change Order once signed by all parties, with the exception of a Unilateral Change Order that is only signed by the Owner, is incorporated into and becomes a part of the Contract.

**Claim:** A demand or assertion by one of the parties seeking, as a matter of right, adjustment or interpretation of Contract terms, payment of money, extension of time or other relief with respect to the terms of the Contract. The term “claim” also includes other disputes and matters in question between the Owner and Contractor arising out of or relating to the Contract. Claims must be made by written notice. The responsibility to substantiate claims shall rest with the party making the claim.

**Code of Virginia:** 1950 Code of Virginia as amended. Sections of the Code referred to herein are noted by §xx-xx.

**Construction:** The term used to include new construction, reconstruction, renovation, restoration, major repair, demolition and all similar work upon buildings and ancillary facilities, including any draining, dredging, excavation, grading or similar work upon real property.

**Contract:** The Contract Between Owner and Contractor, Form AC-9, hereinafter referred to as the Contract.

**Contract Completion Date:** The date by which the Work must be substantially complete. The Contract Completion Date is customarily established in the Notice To Proceed, based on the Time for Completion. In some instances, however, the Contract contains a mandatory Contract Completion Date, which shall be stated in the Invitation for Bid or Request for Proposal, as applicable.

**Contract Documents:** The Contract Between Owner and Contractor (Form AC-9) signed by the Owner and the Contractor and any documents expressly incorporated therein. Such incorporated documents customarily include the bid submitted by the Contractor, these General Conditions, any Supplemental General Conditions, any Special Conditions, the plans and the specifications, and all modifications, including addenda and subsequent Change Orders.

**Contract Price:** The total compensation payable to the Contractor for performing the Work, subject to modification by Change Order.

**Contractor:** The person with whom the Owner has entered into a contractual agreement to do the Work.

**Date of Commencement:** The date as indicated in the written Notice to Proceed or a date mutually agreed to between the Owner and Contractor in writing.

**Day(s):** Calendar day(s) unless otherwise noted.

**Defective:** An adjective which, when modifying the word Work, refers to Work that is unsatisfactory, faulty, deficient, does not conform to the Contract Documents or does not meet the requirements of inspections, standards, tests or approvals required by the Contract Documents, or Work that has been damaged prior to the A/E's recommendation of final payment (unless responsibility for the protection thereof has been assumed by Owner at Substantial Completion or Beneficial Occupancy).

**Drawing:** A page or sheet of the Plans which presents a graphic representation, usually drawn to scale, showing the technical information, design, location, and dimensions of various elements of the Work. The graphic representations include, but are not limited to, plan views, elevations, transverse and longitudinal sections, large and small scale sections and details, isometrics, diagrams, schedules, tables and/or pictures.

**Emergency:** Any unforeseen situation, combination of circumstances, or a resulting state that poses imminent danger to health, life or property.

**Field Order:** A written order issued by the A/E or Owner which clarifies or explains the plans or specifications, or any portion or detail thereof, without changing the design, the Contract Price, the Time for Completion or the Contract Completion Date.

**Final Completion Date:** The date of the Owner's acceptance of the Work from the Contractor upon confirmation from the Architect/Engineer and the Contractor that the Work is totally complete in accordance with Section 43(b).

**Final Payment:** The final payment that the Contractor receives pursuant to the applicable provisions of Section 36, except in the event no final payment is made due to termination of the Contract under either Sections 40 or 41. In the event of a termination for cause under Section 40, the Final Payment shall be when the termination became effective. In the event of a termination for convenience under Section 41, the Final Payment shall be either the payment of compensation for termination that the Contractor receives according to the provisions of Subsection 41, or the Owner's determination that no compensation for termination is due the Contractor under Subsection 41, as the case may be.

**Float:** The excess time included in a construction schedule to accommodate such items as inclement weather and associated delays, equipment failures, and other such unscheduled events. It is the

contingency time associated with a path or chain of activities and represents the amount of time by which the early finish date of an activity may be delayed without impacting the critical path and delaying the overall completion of the Project. Any difference in time between the Contractor's approved early completion date and the Contract Completion Date shall be considered a part of the Project float.

**Float, Free:** The time (in days) by which an activity may be delayed or lengthened without impacting upon the start day of any activity following in the chain.

**Float, Total:** The difference (in days) between the maximum time available within which to perform an activity and the duration of an activity. It represents the time by which an activity may be delayed or lengthened without impacting the Time for Completion or the Contract Completion Date.

**Notice:** All written notices, including demands, instructions, claims, approvals and disapprovals, required or authorized under the Contract Documents. Any written notice by either party to the Contract shall be sufficiently given by any one or combination of the following, whichever shall first occur: (1) delivered by hand to the last known business address of the person to whom the notice is due; (2) delivered by hand to the person's authorized agent, representative or officer wherever they may be found; or (3) enclosed in a postage prepaid envelope addressed to such last known business address and delivered to a United States Postal Service official or mailbox. Notice is effective upon such delivery. All notices to the Owner should be directed to the Project Manager.

Notices transmitted by Facsimile (Fax) or Email are acceptable for the Project. If faxed, Notices shall be transmitted to the Fax number listed in the Contract and shall have a designated space for the Fax Notice recipient to acknowledge his receipt by authorized signature and date. The Fax Notice with authorized signature acknowledging receipt shall be Faxed back to the sender. If emailed, Notices shall be transmitted to the email address listed in the Contract. The Email Notice recipient shall acknowledge receipt by emailing back to the sender and responding to the Emailed Notice. Notice shall be effective upon the date of acknowledgment of the Faxed or Emailed Notice or the date of delivery, whichever occurs first.

**Notice to Proceed:** A written notice given by the Owner to the Contractor (with a copy to A/E) fixing the date on which the Contract time will commence for the Contractor to begin the prosecution of the Work in accordance with the requirements of the Contract Documents. The Notice to Proceed will customarily identify a Contract Completion Date.

**Owner:** County of Albemarle, Virginia and/or The County School Board of Albemarle County, Virginia.

**Permit:** The term "permit" as used herein shall mean any and all permits required to comply with local, state, and federal codes or laws (including but not limited to building permit, erosion and sediment control permit, and any other permit required by state, federal, and local jurisdictions).

**Person:** This term includes any individual, corporation, partnership, association, company, business, trust, joint venture, or other legal entity.

**Plans:** The term used to describe the group or set of project-specific drawings and/or Architect/Engineer sketches which are included in the Contract Documents.

**Project:** The term used instead of the specific or proper assigned title of the entire undertaking which includes, but is not limited to, the “Work” described by the Contract Documents.

**Project Inspector:** One or more persons and/or firms employed by the Owner to inspect the Work for the Owner and/or to document and maintain records of activities at the Site to the extent required by the Owner. The scope of the Project Inspector’s authority with respect to the Contractor is limited to that indicated in Section 16(e) and (f).

**Project Manager:** The Project Manager as used herein shall be the Owner’s designated representative on the Project. The Project Manager shall be the person through whom the Owner generally conveys written decisions and notices. All notices due the Owner and all information required to be conveyed to the Owner shall be conveyed to the Project Manager. The Owner may change the Project Manager from time to time and may, in the event that the Project Manager is absent, disabled or otherwise temporarily unable to fulfill his duties, appoint an interim Project Manager.

**Provide:** Shall mean furnish and install ready for its intended use.

**Schedule of Values:** The schedule prepared by the Contractor and acceptable to the Owner which indicates the value of that portion of the Contract Price to be paid for each trade or major component of the Work.

**Site:** Shall mean the location at which the Work is performed or is to be performed.

**Special Conditions:** Provisions of a contract that are specific to the project under consideration and do not fall under General Conditions or Supplemental General Conditions.

**Specifications:** That part of the Contract Documents containing the written administrative requirements and the technical descriptions of materials, equipment, construction systems, standards, and workmanship which describe the proposed Work in sufficient detail and provide sufficient information for the Code Official to determine code compliance and for the Contractor to perform the Work. (The General Conditions, any Supplemental General Conditions, Special Conditions, various bidding information and instructions, and blank copies of various forms to be used during the execution of the Work are usually bound with the Specifications.)

**Subcontractor:** A person having a direct contract with Contractor or with any other Subcontractor for the performance of the Work. Subcontractor includes any person who provides on-site labor but does not include any person who only furnishes or supplies materials for the Project.

**Submittals:** All shop, fabrication, setting and installation drawings, diagrams, illustrations, schedules, samples, and other data required by the Contract Documents which are specifically prepared by or for the Contractor to illustrate some portion of the Work and all illustrations, brochures, standard schedules, performance charts, instructions, diagrams and other information prepared by a Supplier and submitted by the Contractor to illustrate material or equipment conformance of some portion of the Work with the requirements of the Contract Documents.

**Substantial Completion:** The condition when the Owner agrees that the Work, or a specific portion thereof, is sufficiently complete, in accordance with the Contract Documents, so that it can be utilized by the Owner for the purposes for which it was intended. The Owner at its sole discretion may, after

obtaining the necessary approvals and certificates, take Beneficial Occupancy at this time or choose to wait to occupy until after Final Completion is achieved.

**Supplemental General Conditions:** That part of the Contract Documents which amends or supplements the General Conditions.

**Supplier:** A manufacturer, fabricator, distributor, materialman or vendor who provides material for the Project but does not provide on-site labor.

**Time for Completion:** The number of consecutive calendar days following the issuance of the Notice to Proceed which the Contractor has to substantially complete all Work required by the Contract. When the Notice to Proceed is issued, it states a Contract Completion Date, which has been set by the Owner based on the Time for Completion.

**Underground Facilities:** All pipelines, conduits, ducts, cables, wires, manholes, vaults, tanks, tunnels or other such facilities or attachments, and any encasements containing such facilities which are or have been installed underground to furnish any of the following services or materials: electricity, gases, steam, liquid petroleum products, telephone or other communications, cable television, sewage and drainage removal, traffic or other control systems or water.

**Unilateral Change Order:** A Change Order from the Owner directing the Contractor to proceed with work within the scope of the contract which may be undefined or for which there is no agreement on the cost or time associated with the work.

**Work:** The services performed under this Contract including, but not limited to, furnishing labor, and furnishing and incorporating materials and equipment into the construction. The Work also includes the entire completed construction, or the various separately identifiable parts thereof, required to be provided under the Contract Documents or which may reasonably be expected to be provided as part of a complete, code compliant and functioning system for those systems depicted in the plans and specifications.

## 2. CONTRACT DOCUMENTS

- (a) The Contract Between Owner and Contractor (AC-9), the Standard Performance Bond (AC-10), the Standard Labor and Material Payment Bond (AC-10.1), the Schedule of Values and Certificate for Payment (AC-12), the Affidavit of Payments of Claims (AC-13), the Contractor's Certificate of Substantial Completion (AC-13.2a), and the Contractor's Certificate of Completion (AC-13.2) issued by the County of Albemarle are forms incorporated in these General Conditions by reference and are made a part hereof to the same extent as though fully set forth herein. They must be used by the Contractor for their respective purposes.
- (b) All time limits stated in the Contract Documents, including but not limited to the Time for Completion of the Work, are of the essence of the Contract.
- (c) The Contract Between Owner and Contractor shall be signed by the Owner and the Contractor in as many original counterparts as may be mutually agreed upon, each of which shall be considered an original.

- (d) Anything called for by one of the Contract Documents and not called for by the others shall be of like effect as if required or called for by all, except that a provision clearly designed to negate or alter a provision contained in one or more of the other Contract Documents shall have the intended effect. In the event of conflicts among the Contract Documents, the Contract Documents shall take precedence in the following order: the Contract Between Owner and Contractor; the Special Conditions; the Supplemental General Conditions; the General Conditions; the specifications with attachments; and the plans.
- (e) If any provision of this Contract shall be held invalid by any court of competent jurisdiction, such holding shall not invalidate any other provision.
- (f) All correspondence, invoices, memoranda, submittals and other documents related to this Project whether generated by the Owner, the A/E, the Contractor or others should be identified at the beginning of the document with the Project Title shown in the Contract. Additional identification such as a job number, purchase order number or such may also be shown at the Owner's option.

### **3. LAWS, REGULATIONS AND PERMITS**

- (a) The Contractor shall comply with all laws, ordinances, rules, regulations and lawful orders of any public authority bearing on the performance of the Work and shall give all notices required thereby. The Contractor shall assure that all Subcontractors and tradesmen who perform Work on the project are properly licensed by the Department of Professional and Occupational Regulation as required by Title 54.1, Chapter 11, Articles 1 and 3, Code of Virginia, and by applicable regulations.
- (b) This Contract and all other contracts and subcontracts are subject to the provisions of Articles 3 and 5, Chapter 4, Title 40.1, Code of Virginia, relating to labor unions and the "right to work." The Contractor and its Subcontractors, whether residents or nonresidents of the Commonwealth, who perform any Work related to the Project shall comply with all of the said provisions.
- (c) IMMIGRATION REFORM AND CONTROL ACT OF 1986: By signing this Contract, the Contractor certifies that it does not and will not during the performance of this Contract violate the provisions of the Federal Immigration Reform and Control Act of 1986, which prohibits employment of illegal aliens.
- (d) The provisions of all rules and regulations governing safety as adopted by the Safety Codes Commission of the Commonwealth of Virginia and as issued by the Department of Labor and Industry under Title 40.1 of the Code of Virginia shall apply to all Work under this Contract. Inspectors from the Department of Labor and Industry shall be granted access to the Work for inspection without first obtaining a search or administrative warrant.
- (e) Building Permit: The Virginia Uniform Statewide Building Code applies to the Work and is administered by the local Building Official. The Building Permit will be obtained by the Contractor and paid for by the Owner. All other permits, local license fees, business fees, taxes, or similar assessments shall be obtained and paid for by the Contractor. See Section 25 for utility connection fees and services.

- (f) The Contractor shall include in each of its subcontracts a provision requiring each Subcontractor to include or otherwise be subject to the same payment and interest requirements in Subsections (a), (b), and (c) of Section 37 of these General Conditions with respect to each lower-tier Subcontractor and Supplier.
- (g) The Contractor, if not licensed as an asbestos abatement contractor in accordance with §54.1-514, Code of Virginia, shall have all asbestos-related Work performed by subcontractors who are duly licensed as asbestos contractors for the Work required.
- (h) Lead-Based Paint Activities: If the Contract Documents indicate that lead-based paint is present on existing materials, components, or surfaces, the Contractor shall conform to the following:
  - (1) The requirements set forth in 59 Federal Register 45,872 (September 2, 1994) Proposed Rule - Lead; Requirements for Lead-based Paint Activities (Proposed Rules) in selecting and performing the means, methods and procedures for performing the Work. This includes, but is not limited to, training of personnel, lead abatement, encapsulation of lead containing materials, removal and handling of lead containing materials, and methods of disposal. When the Final Rule, to be codified at 40 CFR 745, supersedes the Proposed Rule, the Contractor shall be responsible for conforming to the Final Rule, as of the effective date set forth therein.
  - (2) The requirements for employee protection contained in 29 CFR Part 1926, Subpart D, and the requirements for record-keeping contained in 29 CFR Part 1910.
  - (3) The Virginia Department of Labor and Industry's (DLI) Emergency Regulation published in the May 27, 1996 Virginia Register, requiring, among other things, that a permit be issued to the lead abatement contractor, or any subsequent regulation issued by DLI.
- (i) If the Contractor violates laws or regulations that govern the Project, the Contractor shall take prompt action to correct or abate such violation and shall indemnify and hold the Owner harmless against any fines and/or penalties that result from such violation. To the extent that such violation is the result of negligence or other actionable conduct of the Contractor, the Contractor shall indemnify and hold the Owner harmless against any third party claims, suits, awards, actions, causes of action or judgments, including but not limited to attorney's fees and costs incurred thereunder, that result from such violation.
- (j) Land Disturbance Activities: If the Work includes any land disturbing activities, the Contractor shall be responsible for obtaining an Albemarle County Land Disturbance Permit. The Contractor shall have an individual certified by the Department of Conservation and Recreation (DCR) as a Responsible Land Disturber (RLD) on the project site at all times during the construction project where land is being disturbed in accordance with §10.1-563, Code of Virginia.

All construction activities involving land disturbances equal to or exceeding ten thousand (10,000) square feet must be covered by a Virginia Stormwater Management Program (VSMP) permit approved and issued by the County in accordance with the County of Albemarle's Water Protection Ordinance. The Owner is responsible for securing permit coverage for all applicable land disturbing activities performed, including within any easements that directly relate to the construction site activity. The Contractor shall sign a certification statement to comply with all conditions of the

permit, shall accept assignment as the responsible party prior to issuance of the Land Disturbance Permit, and shall sign all Responsible Land Disturber (RLD) forms.

The Contractor shall be responsible for securing permit coverage for support facilities that are not located within the project limits of disturbance. The Contractor shall be responsible for all costs to obtain permit coverage for all support facilities (both on-site and off-site) not included in the construction plans or contract documents for the project. The Owner will not be responsible for any inconvenience, delay, or loss experienced by the Contractor as a result of his failure to gain access to any support facility areas at the time contemplated.

- (k) Environmental Permitting: The Contractor shall sign a certification to comply with all conditions of any environmental permits required for the project (e.g. wetland or stream mitigation permit, floodplain development permit, etc.). The Contractor shall adhere to any time-of-year restriction conditions as required by state and federal permitting agencies. No in-stream work shall be permitted during in-stream time-of-year restrictions.
- (l) Virginia Department of Transportation (VDOT) Land Use Permit: The Contractor shall be responsible to obtain a VDOT Land Use Permit for projects requiring such permit. The Contractor shall be responsible for all costs associated with obtaining such permit.
- (m) The Contractor is responsible for ensuring that all permits required to perform the work are obtained and that all conditions of those permits are met throughout the duration of the project.

#### **4. NONDISCRIMINATION**

- (a) §2.2-4311 of the Code of Virginia shall be applicable. It provides as follows:

“1. During the performance of this Contract the Contractor agrees as follows:

- (a) The Contractor will not discriminate against any employee or applicant for employment because of race, religion, color, sex, national origin, age, disability, or other basis prohibited by state law relating to discrimination in employment, except where there is a bona fide occupational qualification reasonably necessary to the normal operation of the Contractor. The Contractor agrees to post in conspicuous places, available to employees and applicants for employment, notices setting forth the provisions of this nondiscrimination clause.
- (b) The Contractor, in all solicitations or advertisements for employees placed by or on behalf of the Contractor, will state that such Contractor is an equal opportunity employer.
- (c) Notices, advertisements and solicitations placed in accordance with federal law, rule or regulation shall be deemed sufficient for the purpose of meeting the requirements of this section.

2. The Contractor will include the provisions of the foregoing paragraphs (a), (b) and c) in every subcontract or purchase order of over ten thousand dollars (\$10,000), so that the provisions will be binding upon each Subcontractor or vendor.”
- (b) Where applicable, the Virginians with Disabilities Act and the Federal Americans with Disabilities Act shall apply to the Contractor and all Subcontractors.

## 5. PROHIBITION OF ALCOHOL AND OTHER DRUGS

- (a) §2.2-4312 of the Code of Virginia shall be applicable. It provides as follows:

“During the performance of this contract, the contractor agrees to (i) provide a drug-free workplace for the contractor’s employees; (ii) post in conspicuous places, available to employees and applicants for employment, a statement notifying employees that the unlawful manufacture, sale, distribution, dispensation, possession, or use of a controlled substance or marijuana is prohibited in the contractor’s workplace and specifying the actions that will be taken against employees for violations of such prohibition; (iii) state in all solicitations or advertisements for employees placed by or on behalf of the contractor that the contractor maintains a drug-free workplace; and (iv) include the provisions of the foregoing clauses in every subcontract or purchase order of over \$10,000, so that the provisions will be binding upon each subcontractor or vendor. For the purposes of this section, “drug-free workplace” means a site for the performance of work done in connection with a specific contract awarded to a contractor in accordance with this chapter, the employees of whom are prohibited from engaging in the unlawful manufacture, sale, distribution, dispensation, possession or use of any controlled substance or marijuana during the performance of the contract.”

- (b) The Contractor shall also establish, maintain and enforce policies which prohibit the following acts by all Contractor, Subcontractor and Supplier personnel at the Site:
  1. the manufacture, distribution, dispensation, possession, or use of alcohol, marijuana or other drugs, except possession and medically prescribed use of prescription drugs; and
  2. the impairment of judgment or physical abilities due to the use of alcohol, marijuana or other drugs, including impairment from prescription drugs.

## 6. TIME FOR COMPLETION

- (a) The Time for Completion shall be designated by the Owner on the Invitation for Bids, Request for Proposals or other prebid/proposal documents. In some instances, the Time for Completion may be stated on the Invitation for Bids, Request for Proposals or other prebid/pre-proposal document in the form of a Contract Completion Date. The Work must be substantially completed by the Time for Completion or the Contract Completion Date. Unless otherwise specified, the Contractor shall achieve Final Completion within thirty (30) days after the date of Substantial Completion.
- (b) The Time for Completion shall be stated in the Contract Between Owner and Contractor and shall become a binding part of the Contract upon which the Owner may rely in planning the use of the

facilities to be constructed and for all other purposes. If the Contractor fails to substantially complete the Work within the Time for Completion or Contract Completion Date, as set forth in the Contract, he shall be subject to payment of actual damages incurred by the Owner or liquidated damages, if provided for in the Contract.

- (c) The Contractor, in submitting his bid, acknowledges that he has taken into consideration normal weather conditions. The listing below defines the monthly anticipated days of adverse weather for each month and is based upon NOAA climatological data for Charlottesville, Virginia. Adverse weather days shall be days of actual precipitation of 0.10 inch or greater.

<u>Jan*</u>	<u>Feb*</u>	<u>Mar*</u>	<u>Apr</u>	<u>May</u>	<u>June</u>	<u>July</u>	<u>Aug</u>	<u>Sep</u>	<u>Oct</u>	<u>Nov</u>	<u>Dec*</u>
6	6	7	6	8	6	8	8	6	5	5	6

\* In addition to the anticipated days of adverse weather noted above, the Contractor must include one day of adverse weather impact (snow, ice, mud) for each day of actual adverse weather during the months of January, February, March, and December.

The anticipated days provided above will constitute the baseline for adverse weather time evaluations.

For projects not involving buildings, throughout the portion of the contract from the date of Notice to Proceed until the project is substantially complete, actual adverse weather days are to be recorded by the Contractor and verified by the A/E each month.

For projects involving buildings, throughout the portion of the contract from the date of Notice to Proceed until the building is “dried in”, actual adverse weather days are to be recorded by the Contractor and verified by the Architect each month. The building shall be considered “dried in” when the exterior block walls or stud and sheathing walls are in place, and a temporary (or permanent) roof is in place. Upon determination by the Owner and Architect that the building is in fact dried in, requests for additional time due to weather delays will not be accepted for any work within the building footprint.

The total anticipated adverse weather days for the project shall be the sum of all the monthly days for each month from the date of Notice to Proceed until the project is substantially complete, or until the date the building is to be “dried in”, according to the Contractor’s schedule.

If the total number of actual adverse weather days plus adverse weather impact days exceeds the anticipated adverse weather days determined above, the excess days may be used as a basis to determine whether a Contractor is entitled to a time extension. The adverse weather must have prevented work for fifty percent (50%) or more of the Contractor’s work day and delayed work critical to the timely completion of the project.

The Contractor’s schedule must indicate the critical (path) work and must reflect the above anticipated adverse weather days for all weather dependent activities.

- (1) The extension requested must be supported by a delay in completion of the entire Project shown on the critical path of the accepted CPM Schedule or the approved bar graph schedule

required for the Project. Extensions will be granted only for delays in completion of the Project, not for that portion of any delay which consumes only “float” time.

- (2) A request for extension of time based on abnormal weather must be made in writing within ten (10) calendar days of the completion of the calendar month during which abnormal weather is claimed at the Site.
- (3) All of the evidence and data supporting the request (including both historical data and the recordings at the Site during the time of delay) must be furnished to the Owner before any consideration will be given to the request. That supporting data shall be submitted by the end of the calendar month following the month for which the request is made. Time extensions for adverse weather related days granted by the Owner will extend the Contract Completion Date but will not include additional compensation to the Contractor. Weather-related time extension(s) shall not be compensable.
- (d) The Contractor represents and agrees that he has taken into account in his bid the requirements of the bid documents, local conditions, availability of materials, equipment, and labor, and any other factors which may affect the performance of the Work. The Contractor agrees and warrants that he will achieve Substantial Completion of the Work to allow the Owner to have Beneficial Occupancy not later than the Time for Completion or Contract Completion Date. The Contractor agrees and warrants that he will achieve Final Completion of the Work (the entire completion of all Work, including “punch list” items), not later than the number of days as specified in the Contract Documents after achieving Substantial Completion.

## **7. CONDITIONS AT SITE**

- (a) The Contractor and its Subcontractors shall have visited the Site prior to bidding or submitting a bid or proposal and are totally responsible for having ascertained pertinent local conditions such as location, accessibility and general character of the Site, and the character and extent of existing conditions, improvements and work within or adjacent to the Site. It is understood that the Contractor accepts conditions at the site as of the date of its bid or proposal and no allowances will be made after award for any future error or negligence by Contractor or Subcontractors. Claims, which result from the Contractor’s failure to do so, will be deemed waived.
- (b) If, in the performance of the Contract, hidden physical conditions of a building being modified are exposed revealing unusual or materially different conditions from those ordinarily encountered or inherent in work of this nature, or if subsurface or latent conditions at the Site are found which are materially different from those frequently present in the locality or from those indicated in the Contract Documents, the Contractor must report such conditions to the Owner and to the Architect/Engineer before the conditions are disturbed. Upon such notice, or upon his own observation of such conditions, the Architect/Engineer shall promptly propose such changes in the Contract Documents as he finds necessary to conform to the different conditions. Any change in the cost of the Work or additional time needed for completion must be requested pursuant to Sections 38 and/or 42 of these General Conditions.

- (c) If the Contractor, during the course of the Work, observes the existence of any material which he knows, should know, or has reason to believe is hazardous to human health, the Contractor shall promptly notify the Owner. The Owner will provide the Contractor with instructions regarding the disposition of the material. The Contractor shall not perform any Work involving the material or any Work causing the material to be less accessible prior to receipt of special instructions from the Owner.

## **8. CONTRACT SECURITY**

- (a) For Contracts with a value exceeding one hundred thousand dollars (\$100,000), the Contractor shall deliver to the Owner or its designated representative, a Standard Performance Bond (Form AC-10) and a Standard Labor and Material Payment Bond (Form AC-10.1), each fully executed by the Contractor and one or more surety companies legally licensed to do business in Virginia and each in an amount equal to one hundred percent (100%) of the accepted bid. The bonds shall identify the name and address of an attorney-in-fact who is appointed to act on behalf of the surety within the Commonwealth of Virginia. The attorney-in-fact shall affix to the bond a certified and current copy of the power of attorney. If more than one Surety executes a bond, each shall be jointly and severally liable to the Owner for the entire amount of the bond. Sureties shall be selected by the Contractor, subject to approval by the Owner. No payment on the Contract shall be due and payable to the Contractor until the bonds have been approved by the Owner. The Standard Performance Bond and Standard Labor and Material Payment Bond will be held for one year after final acceptance of the Work or as described in the bond forms.
- (b) For the purposes of all Standard Labor and Material Payment Bonds entered into, the term “subcontractors” as used in §2.2-4337(A.2) of the Code of Virginia is interpreted to mean any contractors who participated in the prosecution of the Work undertaken by the Contractor (referred to in §2.2-4337(A.2) of the Code of Virginia as the “prime contractor”), whether such contractor had a direct contract with the Contractor (prime contractor) or whether there were one or more other intervening Subcontractors contractually positioned between it and the Contractor (prime contractor).
- (c) See §2.2-4338 of the Code of Virginia, for alternative forms of security for payment and/or performance bonds.
- (d) For contracts with a value of less than one hundred thousand dollars (\$100,000), the Contractor will not be required to provide a Standard Performance Bond and a Standard Labor and Material Payment Bond as described above unless the Invitation for Bid or Request for Proposal states that such bonds will be required.

## **9. SUBCONTRACTS**

- (a) The Contractor shall, as soon as practicable after the signing of the Contract and prior to commencement of Work, notify the Owner and Architect/Engineer in writing of the names of all Subcontractors proposed for the Work and of such others as the Architect/Engineer may direct. Subcontractors whose names do not appear on the list must be approved by the Owner. Where the specifications establish qualifications or criteria for Subcontractors, manufacturers, or individuals

performing Work on the Project, the Contractor shall be responsible for ascertaining that those proposed meet the criteria or qualifications. The Contractor shall not employ any Subcontractor that the Owner may, within a reasonable time, object to as unsuitable. Neither the Owner nor the Architect/Engineer shall direct the Contractor to contract with any particular Subcontractor unless provided in the specifications or Invitation for Bids or Request for Proposal.

- (b) The Owner may select a particular Subcontractor for a certain part of the Work and designate on the Invitation for Bids or Request for Proposal that the Subcontractor shall be used for the part of the Work indicated and that the Subcontractor has agreed to perform the Work for the subcontract amount stipulated on the bid or proposal form. The Contractor shall include in his bid the amount stipulated by the Owner in the bid form. In such case, the Contractor shall be responsible for that Subcontractor and its work and all scheduling and coordination associated with the work. The Subcontractor shall be responsible to the Contractor for its work just as if the Contractor had selected the Subcontractor.
- (c) The Owner shall, on request, furnish to any Subcontractor, if practicable, the amounts of payments made to the Contractor, the Schedule of Values and Requests for Payment submitted by the Contractor and any other documentation submitted by the Contractor which would tend to show what amounts are due and payable by the Contractor to the Subcontractor.
- (d) The Contractor shall be fully responsible to the Owner for all acts and omissions of his agents and employees and all succeeding tiers of Subcontractors and Suppliers performing or furnishing any of the Work. Nothing in the Contract Documents shall create any contractual relationship between Owner or Architect/Engineer and any such Subcontractor, Supplier or other person or organization, nor shall it create any obligation on the part of Owner or Architect/Engineer to pay for or to see to the payment of any moneys due any such Subcontractor, Supplier or other person or organization, except as may otherwise be required by law.
- (e) The Contractor shall be fully responsible for his invitees at the Site and for those of his Subcontractors, Suppliers, and their employees, including any acts or omissions of such invitee.
- (f) The Contractor agrees that he alone is responsible for all dealings with his Subcontractors and Suppliers, and their subcontractors, employees and invitee, including, but not limited to, the Subcontractors' or Suppliers' claims, demands, actions, disputes and similar matters unless specifically provided otherwise by the Contract or by statute.

## **10. SEPARATE CONTRACTS**

- (a) The Owner reserves the right to let other contracts in connection with the Project, the Work under which may proceed simultaneously with the execution of this Contract. The Contractor shall afford other separate contractors reasonable opportunity for the introduction and storage of their materials and the execution of their work. The Contractor shall cooperate with them and shall take all reasonable action to coordinate his Work with theirs. If the Owner has listed other separate contracts in the Invitation for Bids or Request for Proposal which it expects to proceed simultaneously with the Work of the Contractor, and has included the estimated timing of such other Contracts in the Invitation for Bids or Request for Proposal, the Contractor shall integrate the schedule of those separate contracts into his scheduling. The Contractor shall make every reasonable effort to assist

the Owner in maintaining the schedule for all separate contracts. If the work performed by the separate contractor is defective or performed so as to prevent or threaten to prevent the Contractor from carrying out his Work according to the Contract, the Contractor shall immediately notify the Owner and the Architect/Engineer upon discovering such conditions.

- (b) If a dispute arises between the Contractor and any separate contractor(s) as to their responsibility for cleaning up as required by Sections 31(c) and 31(d) of these General Conditions, the Owner may clean up and charge the cost thereof to the respective contractors in proportion to their responsibility. If a Contractor disputes the Owner's apportionment of clean-up costs, it shall be that contractor's burden to demonstrate and prove the correct apportionment.

## 11. CONTRACTOR'S AND SUBCONTRACTOR'S INSURANCE

### A. General Requirements:

(a) Certificate of Insurance-General Contractor: Prior to execution of the Contract by the Owner, the Contractor shall provide written evidence (certificates of insurance) that he has obtained all the insurance required hereunder from an insurer authorized to do business in Virginia and such insurance has been approved by the Owner. Insurance providers must have an agent licensed to do business in Virginia. The Owner must be identified on the certificate(s) of insurance as an additional insured for all types of insurance coverage, except for workers' compensation and professional liability, and there shall be a statement provided on the certificate(s) confirming the Owner is named as an additional insured and so endorsed to the policy(ies). In the event of cancellation of this insurance, not less than thirty (30) days prior written notice must be sent to the Owner.

(b) Certificate of Insurance-Subcontractor: The Contractor shall not allow any Subcontractor to commence Work on his subcontract until the same types of insurance in an appropriate amount have been obtained by the Subcontractor and approved by the Contractor. The Owner shall have no responsibility to verify compliance by the Contractor, or its subcontractors or suppliers. Approval of insurance by the Owner shall not relieve or decrease the liability of the Contractor hereunder. In the event of cancellation of this insurance, not less than thirty (30) days prior written notice must be sent to the Owner.

**B. Insurance Requirements:** By signing and submitting a proposal under this solicitation, the offeror certifies that if awarded the contract, it will purchase and maintain, at its sole expense, and from a company or companies authorized to do business within the Commonwealth of Virginia, insurance policies containing the following types of coverages and minimum limits, protecting from claims which may arise out of or result from the Offerors' performance or non-performance of services under this Contract, or the performance or non-performance of services under this Contract by anyone directly or indirectly employed by the Offeror or for whose acts it may be liable. The Supplemental General Conditions detail the minimum amounts required for this solicitation.

- (a) Workers' Compensation to include Employer's Liability of an amount not less than \$100,000/\$500,000/\$100,000. Coverage is compulsory for employers of three or more employees, to include the employer. Businesses who hire subcontractors who will perform the same trade or are hired to fulfill contract requirements must include the subcontractor's employees when determining the total number of employees for workers compensation. A waiver of subrogation in favor of the County of Albemarle and its officers, employees, agents, and volunteers must be endorsed on the workers

compensation policy. Contractors who fail to notify the County of increases in the number of employees that change their workers' compensation requirements under the Code of Virginia during the course of the contract shall be in noncompliance with the contract. This policy shall specifically list Virginia as a covered state.

- (b) General Liability – of an amount not less than \$1,000,000 per occurrence/\$2,000,000 aggregate limit, and a per project aggregate limit of \$2,000,000.-CGL form CG 2010 11/85 edition or its equivalent is required to be endorsed to the commercial general liability policy. Commercial General Liability is to include bodily injury and property damage, personal injury, advertising injury, arising out of premises, operations, and products and completed operations. The County of Albemarle and its officers, employees, agents and volunteers must be named as additional insureds on a primary and non-contributory basis and be so endorsed on the policy. A waiver of subrogation in favor of Albemarle County Government is required on the commercial general liability policy.
- (c) Automobile Liability – of an amount not less than \$1,000,000 per accident. Coverage is to include hired, owned, non-owned, temporary, and leased vehicles. The County of Albemarle and its officers, employees, agents and volunteers must be named as additional insureds on a primary and non-contributory basis and be so endorsed on the auto policy. A waiver of subrogation naming the County of Albemarle and its officers, employees, agents and volunteers is also required on the commercial auto policy.
- (d) Umbrella or Excess Liability Coverage- of an amount not less than \$1,000,000. Must be follow form and go over the underlying general liability, commercial auto and employers liability policies. The County of Albemarle and its officers, employees, agents and volunteers must be named as additional insureds on a primary and non-contributory basis and be so endorsed on the Umbrella or Excess Liability policy. A waiver of subrogation naming the County of Albemarle and its officers, employees, agents and volunteers is also required on the commercial Umbrella or Excess Liability policy.
- (e) Environmental/pollution - of an amount not less than \$1,000,000. County of Albemarle and its officers, employees, agents and volunteers must be named as additional insureds on a primary and non-contributory basis and be so endorsed on the Environmental/pollution Liability policy. A waiver of subrogation naming the County of Albemarle and its officers, employees, agents and volunteers is also required on the commercial Environmental/pollution Liability policy.
- (f) Professional (E&O) Liability Insurance - of an amount not less than \$1,000,000
- (g) Cyber Liability - of an amount not less than \$1,000,000

**All insurance coverage:**

1. shall be issued by an insurance carrier authorized to do business within the Commonwealth of Virginia and rated A – VIII or better, by A. M. Best Company or equivalent rating from an alternate recognized ratings agency, and otherwise acceptable to the County;
2. shall be kept in force throughout performance of services;
3. shall be an occurrence based policy; professional liability may be claims made basis;
4. shall include completed operations coverage;
5. shall contain a cross liability or severability of interest clause or endorsement. Insurance covering the specified additional insured shall be primary and non-contributory, and all other insurance carried by the additional insureds shall be excess insurance;
6. where additional insured required, such policy shall not have a restriction on the limits of coverage provided to the County as an additional insured. The County shall be entitled to protection up to the full limits of the offerors’s policy regardless of the minimum requirements specified in the Contract.

**Proof Of Insurance:** Prior to performance of any services or delivery of goods, the Offeror shall (i) have all required insurance coverage in effect; (ii) the Offeror shall deliver to the County certificates of insurance for all lines of coverage. The Offeror shall be responsible that such coverage evidenced thereby shall not be substantially modified or canceled without 30 days prior written notice to the County; and (iii) the Offeror shall deliver to the County endorsements to the policies which require the County and its officials, officers, employees, agents and volunteers be named as “additional insured”. Policies which require this endorsement include: Commercial General Liability, Automobile Liability and, umbrella or excess liability coverage as detailed below. Such endorsements must be approved by the County, and (iv) upon the request of the County, provide any other documentation satisfactory to the County in its sole discretion, evidencing the required insurance coverage, including but not limited to a copy of the insurance policy and evidence of payment of policy premiums. The Offeror shall require each of its subcontractors and suppliers to have coverage per the requirements herein in effect, prior to the performance of any services by such subcontractors and suppliers. Further, the Offeror shall ensure that all Required Insurance coverages of its subcontractors and suppliers is and remains in effect during performance of their services on the Project and certifies by commencement of the Work that this insurance and that of subcontractors is in effect and meets the requirements set forth herein. The County shall have no responsibility to verify compliance by the Offeror or its subcontractors and suppliers.

**Effect Of Insurance:** Compliance with insurance requirements shall not relieve the Offeror of any responsibility to indemnify the County for any liability to the County, as specified in any other provision of this contract, and the County shall be entitled to pursue any remedy in law or equity if the Offeror fails to comply with the contractual provisions of this contract. Indemnity obligations specified elsewhere in this Contract shall not be negated or reduced by virtue of any insurance carrier's denial of insurance coverage for the occurrence or event which is the subject matter of the claim, or by any insurance carrier’s refusal to defend any named insured.

**Waiver Of Subrogation:** The Offeror agrees to release and discharge the County of Albemarle and its officers, employees, agents and volunteers of and from all liability to the Offeror, and to anyone claiming by, through or under the Offeror, by subrogation or otherwise, on account of any loss or damage to tools, machinery, equipment or other property, however caused.

**Sovereign Immunity:** Nothing contained herein shall affect, or shall be deemed to affect, a waiver of

the County's sovereign immunity under law.

**Right to Revise or Reject:** The County reserves the right, but not the obligation, to revise any insurance requirement not limited to limits, coverages and endorsements, or reject any insurance policies which fail to meet the criteria stated herein. Additionally, the County reserves the right, but not the obligation, to review and reject any insurer providing coverage due to its poor financial condition or failure to operate legally.

**Umbrella or Excess Liability Coverage** which includes premises/operations, product/completed operations, and has per-occurrence limits as detailed in the Supplemental General Conditions. This insurance shall name the County and its officials, officers, and employees and agents as "additional insureds" by **endorsement** to the Umbrella or Excess Liability policy. Such policy shall not have a restriction on the limits of coverage provided to the County of Albemarle as an additional insured. The County of Albemarle shall be entitled to protection up to the full limits of the Offeror's policy regardless of the minimum requirements specified in this contract.

**Professional Liability Insurance:** At its sole expense, and prior to commencing any activities under this Agreement, Offeror shall secure professional liability insurance, covering any damages caused by the negligent or wrongful acts or omissions of the Offeror, its employees and agents in the performance of this Agreement, with coverage in an amount as detailed in the Supplemental General Conditions ("Required Insurance"). Offeror shall maintain the Required Insurance in effect throughout the Term of this Agreement and for a period of three (3) years following final acceptance of the Project by the County. Upon execution of this Agreement, Offeror shall provide the County with a certificate of insurance, or other written documentation satisfactory to the County in its sole discretion, issued by Offeror's insurance company(ies), confirming the Required Insurance and the beginning and ending date(s) of Contractor's policy(ies). Upon receipt of any notice, verbal or written, that the Required Insurance is subject to cancellation, Offeror shall immediately (within one business day) notify the County. Offeror's failure to comply with any of the requirements of this Section shall constitute a material breach of this Agreement entitling the County to terminate this Agreement without notice to Offeror and without penalty to the County.

**C. Installation Floater:** if applicable, the Contractor is required to purchase an Installation Floater to cover their own property to be installed into a building. Coverage is provided for equipment and/or machinery being installed, renovated or repaired during the course of construction.

## 12. BUILDER'S RISK INSURANCE

(a) The Contractor, at his cost, shall obtain and maintain in the names of the Owner and the Contractor builder's risk insurance on a special causes of loss form, including the costs of excavations, backfills, foundations, underground utilities and site work (or fire, extended coverage, vandalism and malicious mischief insurance, if approved by the Owner) upon the entire structure or structures on which the Work of this Contract is to be done, and upon all material in or adjacent thereto which is intended for use thereon, to one hundred percent (100%) of the insurable value thereof. Such insurance may include a deductible provision if the Owner so provides in the Supplemental General Conditions, in which case the Contractor will be liable for such deductions, whenever a claim arises. The loss, if any, is to be made adjustable with and payable to the Owner, in accordance with its interests, as they may appear. The Owner, its officers, employees and its agents, shall be named as

loss payee in any policy of insurance issued. Written evidence of the insurance shall be filed with the Owner prior to execution of the Contract by the Owner. Insurance providers must be authorized to do business in Virginia and have an agent licensed to do business in Virginia. In the event of cancellation of this insurance, not less than thirty (30) days prior written notice must be sent to the Owner. A copy of the policy of insurance shall be given to the Owner upon demand.

- (b) Certain projects, such as renovations and interior modifications of existing buildings, may be covered by the Owner's insurance and may be excluded from the Builder's risk policy purchased by the contractor insurance required by this section. In those instances, the Supplemental General Conditions for the project shall expressly exclude the project from the requirements of Subsection 12(a).
- (c) Any insurance provided through the County of Albemarle, Virginia, for construction, additions or renovations will not extend to Contractor's nor Subcontractors' buildings, equipment, materials, tools or supplies unless these items are to become property of the Owner upon completion of the Project and the Owner has assumed responsibility for such items at the time of the loss.

### **13. TAXES, FEES AND ASSESSMENTS**

The Contractor shall, without additional expense to the Owner, pay all applicable federal, state, and local taxes, fees, and assessments except the taxes, fees and assessments on the real property comprising the Site of the project. The Owner shall pay inspection fees to the local building official except for reinspection fees resulting from incomplete or defective work.

### **14. PATENTS**

The Contractor shall obtain all licenses necessary to use any invention, article, appliance, process or technique of whatever kind and shall pay all royalties and license fees. The Contractor shall hold the Owner, its officers, agents and employees, harmless against any loss or liability for or on account of the infringement of any patent rights in connection with any invention, process, technique, article or appliance manufactured or used in the performance of the Contract, including its use by the Owner, unless such invention, process, technique, article or appliance is specifically named in the specifications or plans as acceptable for use in carrying out the Work. If, before using any invention, process, technique, article or appliance specifically named in the specifications or plans as acceptable for use in carrying out the Work, the Contractor has or acquires information that the same is covered by letters of patent making it necessary to secure the permission of the patentee, or other, for the use of the same, he shall promptly advise the Owner and the Architect/Engineer. The Owner may direct that some other invention, process, technique, article or appliance be used. Should the Contractor have reason to believe that the invention, process, technique, article or appliance so specified is an infringement of a patent, and fail to inform the Owner and the Architect/Engineer, he shall be responsible for any loss or liability due to the infringement.

### **15. ARCHITECT/ENGINEER'S STATUS**

- (a) The Architect/Engineer shall have authority to endeavor to secure the faithful performance by Owner and Contractor of the Work under the Contract. He shall review the Contractor's Submittals for conformance to the requirements of the Contract Documents and return copies to the Contractor with appropriate notations. He shall interpret the requirements of the plans and specifications and issue Field Orders to the Contractor as may be required. He shall recommend to the Owner suspension of the Work (in whole or in part) whenever such suspension may be necessary to ensure the proper execution of the Contract. He shall have authority to reject, in writing, Work, including material, installation or workmanship, which does not conform to the requirements of the plans and specifications. He shall determine the progress and quality of the Work, subject to the right of the Owner to make an overriding decision to the contrary. Upon request by the Contractor, the Architect/Engineer shall confirm, in writing within ten (10) days, any oral order or determination made by him.
- (b) The Architect/Engineer shall have no authority to approve or order changes in the Work which alter the design concept or which call for an extension of time or a change in the Contract Price.
- (c) The Owner shall have the right, but not the duty, to countermand any decision of the Architect/Engineer and to follow or reject the advice of the Architect/Engineer, including but not limited to acceptance of the Work.
- (d) All orders from the Owner to the Contractor shall either be transmitted through the Architect/Engineer or communicated directly to the Contractor and the Architect/Engineer by the Owner.
- (e) Should the Owner choose to employ another or different Architect/Engineer, the status of the Architect/Engineer so employed shall be the same as that of the former Architect/Engineer.
- (f) The Architect/Engineer will provide to the Owner and the Contractor after each visit to the Site, a written report indicating the date, time of day, weather conditions and the names of the persons representing the Architect/Engineer who participated in the visit. The report will advise the Owner of any problems that were noted and shall compare the Architect/Engineer's observations of the actual progress of the Work with that reported by the Contractor. On the basis of his on-site observations as Architect/Engineer, he will make every reasonable effort to guard the Owner against defects and deficiencies in the Work of the Contractor. He shall have the authority to inspect the Work, to note and report Defective Work and deviations from the Contract Documents to the Owner, to reject same, and to recommend to the Owner the suspension of the Work when necessary to prevent Defective Work from proceeding or being covered.
- (g) The Architect/Engineer shall not be responsible for construction means, methods, techniques, sequences or procedures (other than those expressly specified in Contract Documents), or for safety precautions and programs in connection with the Work, and he shall not be responsible for the Contractor's failure to carry out the Contractor's own responsibilities.
- (h) The provisions of this section are included as information only to describe the relationship between the Owner, A/E, and Contractor. No failure of the A/E to act in accordance with this section shall relieve the Contractor from his obligations under the Contract or create any rights in favor of the Contractor.

## 16. INSPECTION

- (a) All material and workmanship shall be subject to inspection, examination and testing by the Owner, the Architect/Engineer, the Project Inspector, authorized inspectors and authorized independent testing entities at any and all times during manufacture and/or construction. The Architect/Engineer and the Owner shall have authority to reject defective material and workmanship and require its correction. Rejected workmanship shall be satisfactorily corrected and rejected material shall be satisfactorily replaced with proper material without charge therefor, and the Contractor shall promptly segregate and remove the rejected material from the Site. If the Contractor fails to proceed at once with replacement of rejected material and/or the correction of defective workmanship, the Owner may, by contract or otherwise, replace such material and/or correct such workmanship and charge the cost to the Contractor, or may terminate the right of the Contractor to proceed as provided in Section 40 of these General Conditions, the Contractor and surety being liable for any damage to the same extent as provided in Section 40 for termination thereunder.
- (b) Site inspections, tests conducted on Site or tests of materials gathered on Site, which the Contract requires to be performed by independent testing entities, shall be contracted and paid for by the Owner. The Contractor shall schedule all required tests, approvals and inspections of the Work or other work related to the Project. If items/areas to be inspected and/or tested are not ready for inspection when the testing agency/inspector arrives on-site at the pre-arranged time, the Contractor is responsible for all costs associated with inspection delays, including but not limited to reinspection fees. The Contractor shall give proper notice to all required parties of such tests, if feasible, so that the Owner and others may observe the tests at the normal place of testing. Unless otherwise required by the Contract Documents, required certificates of testing, approval or inspection shall be secured by the Contractor and promptly delivered to the Owner. Examples of such tests are the testing of cast-in-place concrete, foundation materials, soil compaction, pile installations, caisson bearings and steel framing connections. The Contractor shall promptly furnish, without additional charge, all reasonable facilities, labor and materials necessary and convenient for making such tests. Except as provided in (d) below, whenever such examination and testing finds defective materials, equipment or workmanship, the Contractor shall reimburse the Owner for the cost of reexamination and retesting. Although conducted by independent testing entities, the Owner will not contract and pay for tests or certifications of materials, manufactured products or assemblies which the Contract, codes, standards, etc., require to be tested and/or certified for compliance with industry standards such as Underwriters Laboratories, Factory Mutual or ASTM. If fees are charged for such tests and certifications, they shall be paid by the Contractor. The Contractor shall also pay for all inspections, tests, and certifications which the Contract specifically requires him to perform or to pay, together with any inspections and tests which he chooses to perform for his own purposes, but are not required by the Contract.
- (c) Where Work is related to or dependent on the Defective Work, the Contractor shall stop such related or dependent Work until the Defective Work or deficiency is corrected or an alternative solution is presented that is satisfactory to the Owner. Where Work is rejected because of defective material or workmanship, the Contractor shall stop like Work in other areas or locations on the Project until the matter is resolved and the Owner has approved corrective measures.
- (d) Should it be considered necessary or advisable by the Owner at any time before final acceptance of the entire Work to make an examination of any part of the Work already completed, by removing or tearing out portions of the Work, the Contractor shall on request promptly furnish all necessary

facilities, labor and material to expose the Work to be tested to the extent required. If such Work is found to be defective in any respect, due to the fault of the Contractor or his Subcontractors, the Contractor shall defray all the expenses of uncovering the Work, of examination and testing, and of satisfactory reconstruction. If, however, such Work is found to meet the requirements of the Contract, the actual cost of the Contractor's labor and material necessarily involved in uncovering the Work, the cost of examination and testing, and Contractor's cost of material and labor necessary for replacement including a markup of ten percent (10%) for overhead and profit shall be paid to the Contractor and he shall, in addition, if completion of the Work has been delayed thereby, be granted a suitable extension of time. Notwithstanding the foregoing, the Contractor shall be responsible for all costs and expenses in removing and replacing the Work if the Contractor had covered the Work prior to any inspection or test contrary to the instructions of the A/E, Owner or Project Inspector.

- (e) The Project Inspector has the right and the authority to:
- (1) Inspect all construction materials, equipment, and supplies for quality and for compliance with the Contract Documents and/or approved shop drawings and submittals;
  - (2) Inspect workmanship for compliance with the standards described in the Contract Documents;
  - (3) Observe and report on all tests and inspections performed by the Contractor;
  - (4) Recommend rejection of Work which does not conform to requirements of the Contract Documents;
  - (5) Keep a record of construction activities, tests, inspections, and reports;
  - (6) Attend all joint Site construction meetings and inspections held by the Owner and/or the A/E with the Contractor;
  - (7) Check materials and equipment, together with documentation related thereto, delivered for conformance with approved Submittals and the Contract;
  - (8) Check installations for proper workmanship and conformance with shop drawing and installation instructions;
  - (9) Assist in the review and verification of the Schedule of Values & Certificate for Payment, submitted by the Contractor each month;
  - (10) Do all things for or on behalf of the Owner as the Owner may subsequently direct in writing.
- (f) The Project Inspector has no authority to:
- (1) Authorize deviations from the Contract Documents;
  - (2) Enter into the area of responsibility of the Contractor's superintendent;
  - (3) Issue directions relative to any aspect of construction means, methods, techniques, sequences or procedures, or in regard to safety precautions and programs in connection with the Work;

- (4) Authorize or suggest that the Owner occupy the Project, in whole or in part; or
- (5) Issue a certificate for payment.
- (g) The duties of the Project Inspector are for the benefit of the Owner only and not for the Contractor. The Contractor may not rely upon any act, statement, or failure to act on the part of the Project Inspector, nor shall the failure of the Project Inspector to properly perform his duties in any way excuse Defective Work or otherwise improper performance of the Contract by the Contractor.

## **17. PROJECT MANAGEMENT AND SUPERVISION BY CONTRACTOR**

- (a) The Contractor shall have a competent project manager or superintendent, satisfactory to the Architect/Engineer and the Owner, on the Site at all times during the progress of the Work. The Contractor shall submit for approval by the Owner and Architect/Engineer the resumes for the proposed project manager and superintendent within ten (10) days from Notice of Intent to Award Contract. The project manager and superintendent shall be familiar with and be able to read and understand the plans and specifications, and be capable of communicating orally and in writing with the Owner's project manager and/or inspectors and the Contractor's workers. The Contractor shall be responsible for all construction means, methods, techniques, sequences and procedures, for coordinating all portions of the Work under the Contract except where otherwise specified in the Contract Documents, and for all safety and worker health programs and practices. The Contractor shall notify the Owner, in writing, and obtain approval, of any proposed change in project manager or superintendent, including the reason therefor, prior to making such change.
- (b) The Contractor shall, at all times, enforce strict discipline and good order among the workers on the Project, and shall not employ on the Work, or contract with, any unfit person, anyone not skilled in the Work assigned to him, or anyone who will not work in harmony with those employed by the Contractor, the Subcontractors, the Owner or the Owner's separate contractors and their subcontractors.
- (c) The Owner may, in writing, require the Contractor to remove from the Site any employee or Subcontractor's employee the Owner deems to be incompetent, careless, not working in harmony with others on the Site, or otherwise objectionable, but the Owner shall have no obligation to do so.

## **18. CONSTRUCTION SUPERVISION, METHODS AND PROCEDURES**

- (a) The Contractor shall be solely responsible for supervising and directing the Work competently and efficiently, devoting such attention thereto and applying such skills and expertise as may be necessary to perform the Work in accordance with the Contract. The Contractor shall be solely responsible for the means, methods, techniques, sequences and procedures of construction and for coordinating all portions of the Work under the Contract, except where otherwise specified in the Contract Documents. However, the Contractor shall not be responsible for the negligence of others in the design or selection of a specific means, method, technique, sequence or procedure of construction which is indicated in and required by the Contract. The Contractor is solely responsible to the Owner that the finished Work complies with the Contract Documents.

The Contractor shall be solely responsible for health and safety precautions and programs for workers and others in connection with the Work. No inspection by, knowledge on the part of, or acquiescence by the Architect or Engineer, the Project Inspector, the Owner, the Owner's employees and agents, or any other entity whatever shall relieve the Contractor from its sole responsibility for compliance with the requirements of the Contract or its sole responsibility for health and safety programs and precautions.

- (b) If a specific means, method, technique, sequence or procedure of construction is indicated in or required by the Contract Documents, the Contractor may furnish or utilize a substitute means, method, sequence, technique or procedure of construction acceptable to Architect/Engineer, subject to the Owner's right to disapprove. The Contractor must submit its written request for the substitution to the Architect/Engineer with sufficient information to allow the Architect/Engineer to determine that the substitute proposed is equivalent to that indicated or required by the Contract.
- (c) The divisions and sections of the Specifications and the identification of any drawings shall not control the Contractor in dividing the Work among Subcontractors or Suppliers or delineating the Work to be performed by any specific trade.

## 19. SCHEDULE OF THE WORK

- (a) **General:** The Contractor is responsible for the scheduling and sequencing of the Work, for coordinating the Work, for monitoring the progress of the Work, and for taking appropriate action to keep the Work on schedule. The Contractor may attempt to achieve Substantial Completion on or before the Time for Completion or the Contract Completion Date established by the Contract and receive payment in accordance with Section 36 for the Work completed each period. However, the date established by the Contract Documents as the deadline for achieving Substantial Completion must be used in all schedules as the date on which Substantial Completion will be achieved. The time (in days) between the Contractor's planned early completion and the contracted Time for Completion is part of the Project "Total Float" time and will be used as such. Extensions of time pursuant to Sections 38 and 42, damages for delay, and all other matters between the Owner and the Contractor will be determined using the contractually required Substantial Completion date, not an early Substantial Completion date planned by the Contractor.

Within two (2) weeks after the Contractor signs the Contract Between Owner and Contractor, unless otherwise extended by the Owner at the time of the signing, the Contractor shall prepare and submit to the Owner, with a copy to the Architect/Engineer, a preliminary bar graph milestone schedule for accomplishing the Work based upon the Time for Completion stated in the Contract. The preliminary bar graph schedule shall be in sufficient detail to show the sequencing of the various trades for each floor level, wing or work area. The Owner will notify the Contractor of its acceptance of or objections to the preliminary schedule within seven (7) days of receipt by the Owner. A fully complete Project schedule for accomplishing the Work must be submitted and approved by the Owner prior to making application for the first payment.

The Owner's failure to reject or its acceptance of any schedule, graph, chart, recovery schedule, updated schedule, plan of action, etc. shall not constitute a representation or warranty by the Owner, including but not limited to a representation or warranty that the schedule is feasible or practical nor

shall any such acceptance or failure to reject relieve the Contractor from sole responsibility for completing the Work within the time allowed.

No progress payments will be payable to the Contractor until after it has submitted a preliminary schedule which is acceptable to the Owner. Neither the second progress payment nor any subsequent payment shall be payable to the Contractor until it has submitted a fully complete Project schedule accepted by the Owner. Nor shall subsequent progress payments be payable to the Contractor unless and until he maintains the monthly bar graphs or status reports required by Section 19(e) herein or unless and until he provides any recovery schedule pursuant to Section 19(f) herein.

Failure to provide a satisfactory preliminary or fully complete Project schedule within the time limits stated above shall be a breach of contract for which the Owner may terminate the Contract in the manner provided in Section 40 of these General Conditions.

The fully complete Project schedule for accomplishing the Work shall be of the type set forth in subparagraph (1) or (2) below, as appropriate:

- (1) For Contracts with a price of \$500,000 or less, a bar graph schedule will satisfy the above requirement. The schedule shall indicate the estimated starting and completion dates for each major element of the work. See (b) below.
- (2) For Contracts with a price over \$500,000, a Critical Path Method (CPM) schedule shall be utilized to control the planning and scheduling of the Work. The CPM schedule shall be the responsibility of the Contractor and shall be paid for by the Contractor. See (c) below.

- (b) **Bar Graph Schedule:** Where a bar graph schedule is required, it shall be time-scaled in weekly increments, shall indicate the estimated starting and completion dates for each major element of the Work by trade and by area, level, or zone, and shall schedule dates for all salient features, including but not limited to the placing of orders for materials, submission of shop drawings and other Submittals for approval, approval of shop drawings by Architect/Engineer, the manufacture and delivery of material, the testing and the installation of materials, supplies and equipment, and all Work activities to be performed by the Contractor.

The Contractor shall allow sufficient time in his schedule for adverse weather anticipated in Section 6 and for the A/E to conduct whatever associated reviews or inspections as may be required under the A/E's contract with the Owner. If the A/E and the Contractor are unable to agree as to what constitutes sufficient time, the Owner shall determine the appropriate duration for such Architect/Engineer activities. Each Work activity will be assigned a time estimate by the Contractor. One day shall be the smallest time unit used.

It is the Contractor's responsibility to submit a schedule that shows Substantial Completion of the Work by the Contract Time for Completion or the Contract Completion Date and any interim deadlines established by the Contract.

- (c) **CPM Schedule:** Where a CPM schedule is required, it shall be in the time-scaled precedence format using the Contractor's logic and time estimates. The CPM schedule shall be drawn or plotted with activities grouped or zoned by Work area or subcontract as opposed to a random (or scattered) format.

The CPM schedule shall be time-scaled on a weekly basis and shall be drawn or plotted at a level of detail and logic which will schedule all salient features of the Work, including not only the actual construction Work for each trade, but also the submission of shop drawings and other Submittals for approval, approval of shop drawings by Architect/Engineer, placing of orders for materials, the manufacture and delivery of materials, the testing and installation of materials and equipment, and all Work activities to be performed by the Contractor. Failure to include any element of Work required for the performance of this Contract shall not excuse the Contractor from completing all Work required within the Time for Completion, Contract Completion Date and any interim deadlines established by the Contract.

The Contractor shall allow sufficient time in his schedule for adverse weather anticipated in Section 6 and for the A/E to conduct whatever associated reviews or inspections as may be required under the A/E's contract with the Owner. If the A/E and the Contractor are unable to agree as to what constitutes sufficient time, the Owner shall determine the appropriate duration for such Architect/Engineer activities. Each Work activity will be assigned a time estimate by the Contractor. One day shall be the smallest time unit used.

It is the Contractor's responsibility to submit a schedule that shows Substantial Completion of the Work by the Contract Time for Completion or the Contract Completion Date and any interim deadlines established by the Contract.

When completed, the CPM schedule shall be submitted to the Architect/Engineer and the Owner for review. The CPM schedule will identify and describe each activity, state the duration of each activity, the calendar dates for the early and late start and the early and late finish of each activity, and clearly highlight all activities on the critical path. "Total float" and "free float" shall be indicated for all activities. Float time, whether "free float" or "total float" as defined in Section 1, shall not be considered for the exclusive use or benefit of either the Owner or the Contractor, but must be allocated in the best interest of completing the Work within the Time for Completion or the Contract Completion Date. Extensions to the Time for Completion or the Contract Completion Date, when granted by Change Order, will be granted only when equitable time adjustment exceeds the Total Float in the activity or path of activities affected by the change. The CPM schedule shall also show what part of the Contract Price (expressed in U.S. dollars) is attributable to each activity on the schedule, the sum of which for all activities shall equal the total Contract Price. The CPM schedule shall also show the planned workforce (crew size and number of crews) and the major pieces of equipment required for each activity on the schedule. When acceptable to the Owner and Architect/Engineer as to compliance with the requirements of this Section, but not as to logic, the schedule shall become the CPM schedule for the Project. Acceptance of the schedule by the Owner does not indicate agreement with nor responsibility for the proposed or actual duration of any activity shown on the accepted schedule.

- (d) **Progress of Work:** The Contractor shall commence and complete the work in accordance with the approved schedule. Contractor acknowledges that it may be required to perform Work out of the sequence originally planned to maintain progress on the project. Contractor acknowledges that it has anticipated certain reasonable delays and disruptions as part of the contract price. No additional reimbursement will be forthcoming for out of sequence work. Time is of the essence. If the Contractor fails to employ sufficient competent personnel as may be required to perform the Work or otherwise causes delays which result in the Contractor's failure to complete the Work in the given time, the Contractor will indemnify and hold the Owner harmless for any additional expenses or

damages (including, but not limited to, liquidated damages) arising out of such delay or inability to proceed with the Work. Liquidated Damages, if any, shall be referenced in the Supplemental General Conditions.

- (e) **Monthly Project Reports:** The Contractor shall review progress not less than each month, but as often as necessary to properly manage the Project and stay on schedule. The Contractor shall collect and preserve information on Change Orders, including extensions of time. The Contractor shall evaluate this information and update the latest accepted schedule as often as necessary to finish within the Contract Time for Completion or before the Contract Completion Date. The Contractor shall submit to the A/E along with his monthly request for payment a copy of the bar graph schedule annotated to show the current progress. For projects requiring a CPM schedule, the Contractor shall submit a monthly report of the status of all activities. The bar graph schedule or monthly status report submitted with each periodic request for payment shall show the Work completed to date in comparison with the Work scheduled for completion, including but not limited to the dates for the beginning and completion of the placing of orders; the manufacture, testing and installation of materials, supplies and equipment. The form shall be approved by the A/E and the Owner; however, a bar graph or a CPM schedule marked, colored or annotated to reflect the above will usually satisfy this requirement. If any elements of the Work are behind schedule, regardless of whether they may prevent the Work from being completed on time, the Contractor must indicate in writing in the report what measures he is taking and plans to take to bring each such element back on schedule and to ensure that the Time for Completion or Contract Completion Date is not exceeded.
- (f) **Progress Delay:** Should any of the following conditions exist, the Owner may require the Contractor to prepare, at no extra cost to the Owner, a plan of action and a recovery schedule for completing the Work by the Contract Time for Completion or the Contract Completion Date:
- (1) The Contractor' monthly progress report indicates delays that are, in the opinion of the A/E or the Owner, of sufficient magnitude that the Contractor's ability to complete the Work by the scheduled Time for Completion or the Contract Completion Date is brought into question;
  - (2) The CPM schedule sorted by early finish shows the Contractor to be thirty (30) or more days behind the critical path schedule at any time during construction up to thirty (30) days prior to scheduled Substantial Completion date;
  - (3) The Contractor desires to make changes in the logic (sequencing of Work) or the planned duration of future activities of the CPM schedule which, in the opinion of the Architect/Engineer or the Owner, are of a major nature.

The plan of action and recovery schedule, when required, shall explain and display how the Contractor intends to regain compliance with the current accepted, fully completed, Project CPM schedule, as updated by approved change orders.

The plan of action, when required, shall be submitted to the Owner for review within two (2) business days of the Contractor receiving the Owner's written demand. The recovery schedule, when required, shall be submitted to the Owner within five (5) calendar days of the Contractor's receiving the Owner's written demand.

If, in the opinion of the A/E or Owner, the recovery schedule is deemed insufficient, the Contractor, if directed by the Owner, will be required to remedy the schedule delay, without additional compensation, by one of the following manners:

- (1) Increased manpower by Contractor or its subcontractors;
  - (2) Increased number of shifts, including night and weekend work.
- (g) **Early Completion of Project:** The Contractor may attempt to achieve Substantial Completion on or before the Time for Completion or the Contract Completion Date. However, such planned early completion shall be for the Contractor's convenience only and shall not create any additional rights of the Contractor or obligations of the Owner under this Contract, nor shall it change the Time for Completion or the Contract Completion Date. The Contractor shall not be required to pay damages to the Owner because of its failure to achieve Substantial Completion by its planned earlier date. Likewise, the Owner shall not pay the Contractor any additional compensation for achieving Substantial Completion early nor will the Owner owe the Contractor any compensation should the Owner, its officers, employees, or agents cause the Contractor not to achieve Substantial Completion earlier than the date required by the Contract Documents.

If the Contractor seeks to change the Time for Completion or the Contract Completion Date to reflect an earlier completion date, he may request or propose such a change. The Owner may, but is not required to, accept such proposal. However, a change in the Time for Completion or the Contract Completion Date shall be accomplished only by Change Order. If the Contractor's proposal to change the Time for Completion or the Contract Completion Date is accepted, a Change Order will be issued stating that all references in the Contract, including these General Conditions, to the Time for Completion or the Contract Completion Date shall thereafter refer to the date as modified, and all rights and obligations, including the Contractor's liability for actual damages, delay damages and/or liquidated damages, shall be determined in relation to the date, as modified.

## 20. SCHEDULE OF VALUES AND CERTIFICATE FOR PAYMENT

- (a) Before submittal of the first partial payment request under the Contract, the Contractor shall prepare for review and approval of the Architect/Engineer and the Owner, a schedule of the estimated values listed by trades or by specification sections of the Work, totaling the Contract Price. Where the total project has multiple parts or phases, the Contractor shall prepare appropriate schedules of values to facilitate reviews and justifications for payments.

All requests for payment shall be made on the Schedule of Values and Certificate for Payment (Form AC-12) pages 1 and 2. Succeeding pages may be on the Form AC-12 continuation sheets or a computerized spreadsheet which is in the same format and which contains the same information.

- (b) If the Contractor requests, or intends to request, payment for materials stored in an approved and secure manner, the Schedule of Values must indicate the amount for labor and the amount for materials, and in a supplement thereto must include an itemized list of materials for that trade or Work section. The material breakdown shall be in sufficient detail to allow verification of the quantities required for the Project, the quantities delivered, the Work completed, and the quantities stored on or off Site. Refer to Section 36 of these General Conditions for additional requirements associated with stored materials and/or equipment.

- (c) The “Value of Work Completed” portion of the Form AC-12 shall be completed, the Contractor’s certification completed and signed, and the appropriate substantiating material attached to each Certificate for Payment (AC-12). Such substantiating material includes, but is not limited to, invoices for materials, delivery tickets, time sheets, payroll records, daily job logs/records, and similar materials which, in the opinion of the Owner and the A/E, are necessary or sufficient to justify payment of the amount requested.
- (d) The labor progress for any task or activity shall be calculated based upon the percentage of Work complete up to fifty percent (50%) of the completion of the task or activity. Thereafter, the evaluation of labor progress will be based upon the effort required to complete that task or activity. The material progress shall be calculated as the invoiced dollar cost of materials used in relationship to the amount estimated as necessary to complete a particular element of Work. When calculating material progress, credit shall be given for installed material as well as that stored on the Site and any material stored off Site which has been certified by the Architect/Engineer in accordance with Section 36 of these General Conditions.
- (e) Should Work included in previous Form AC-12 submittals, and for which payment has been made, subsequently be identified, by tests, inspection, or other means, as not acceptable or not conforming to Contract requirements, the “Value of Work Completed” portion of the first Form AC-12 submitted after such identification shall be modified to reduce the “completed” value of that Work by deleting the value of that which has been identified as not acceptable or nonconforming.
- (f) The Contractor shall not include Change Order work on the Form AC-12 until such time as the Contractor is in receipt of a fully executed Change Order from the Owner.

## **21. ACCESS TO WORK**

The Architect/Engineer, the Owner, the Project Manager, the Owner’s inspectors and other testing personnel, inspectors from the Department of Labor and Industry, and others authorized by the Owner, shall have access to the Work at all times. The Contractor shall provide proper facilities for access and inspection.

## **22. SURVEYS AND LAYOUT**

- (a) The Owner shall furnish the Contractor all necessary documents showing property lines and the location of existing buildings and improvements. The Contractor shall provide competent surveying and engineering services to execute the Work in accordance with the Contract and shall be responsible for the accuracy of these surveying and engineering services.
- (b) Such general reference points and benchmarks on the Site as will enable the Contractor to proceed with the Work will be established in the plans and specifications. If the Contractor finds that any previously established reference points have been lost or destroyed, he shall promptly notify the Architect/Engineer.

- (c) The Contractor shall protect and preserve the established benchmarks and monuments and shall make no changes in locations without written notice to the Architect/Engineer and the written approval from the Owner. Any of these which may be lost or destroyed or which require shifting because of necessary changes in grades or locations shall, subject to prior written approval of the Owner, be replaced and accurately located by the Contractor.

## **23. PLANS AND SPECIFICATIONS**

- (a) The general character and scope of the Work are illustrated by the plans and the specifications. If the Contractor deems additional detail or information to be needed, he may request the same in writing from the Architect/Engineer. His request shall precisely state the detail or information needed and shall explain why it is needed. The Contractor shall also indicate a date when the requested information is required. The Architect/Engineer shall provide by Field Order such further detail and information as is necessary by the date required so long as the date indicated is reasonable. Any additional drawings and instructions supplied to the Contractor shall be consistent with the Contract Documents, shall be true developments thereof, and shall be so prepared that they can be reasonably interpreted as a part thereof. The Contractor shall carry out the Work in accordance with the additional detail drawings and instructions.
- (b) If the Contractor finds a contract error, or other discrepancy in the plans or specifications, he shall notify the Architect/Engineer in writing as soon as possible, but before proceeding with the affected Work. The Architect/Engineer shall issue a clarification by Field Order to the Contractor stating the correct requirements. If the Contractor deems the Field Order requires additional Work, he shall notify the A/E of such prior to proceeding with that Work and he shall submit a request for Change Order along with a detailed substantiating cost proposal thru the A/E to the Owner within ten (10) calendar days.
- (c) In case of differences between small and large scale drawings, the large scale drawings shall govern. Where on any of the drawings a portion of the Work is drawn out and the remainder is indicated in outline, the parts drawn out shall apply also to all other like portions of the Work.
- (d) Where the word “similar” appears on the drawings, it shall be interpreted in its general sense and not as meaning identical, and all details shall be worked out in relation to their location and their connection with other parts of the Work.
- (e) The specifications may be divided into several parts, or sections, for convenience only, since the entire specifications must be considered as a whole. The divisions of the specifications are not intended to control the Contractor in dividing the Work among Subcontractors or to limit the Work performed by any trade. The Contractor shall be solely responsible for the coordination of the trades, Subcontractors and vendors engaged in the Work.
- (f) Measurements or dimensions shown on the drawings for Site features, utilities and structures shall be verified at the Site by the Contractor. The Contractor shall not scale measurements or dimensions from the drawings. If there are discrepancies, the Architect/Engineer shall be consulted. If new Work is to connect to, match with or be provided in existing Work, the Contractor shall verify the actual existing conditions and necessary dimensions prior to ordering or fabrication.

- (g) **As-Built Drawings:** The Contractor shall maintain at the Site for the Owner one copy of all drawings, specifications, addenda, approved shop or setting drawings, Change Orders and other modifications (collectively referred to herein as “As-Built Drawings”) in good order and marked to record all changes as they occur during construction. These shall be available to the Architect/Engineer, the Owner, the Project Inspector, the Owner’s other inspectors and to the Owner’s testing personnel. The drawings shall be neatly and clearly marked in color during construction to record all variations made during construction. The representation of such variations shall include such supplementary notes, symbols, legends, and details as may be necessary to clearly show the as-built construction. These As-Built Drawings are to be a separate set of drawings from the set of drawings used by the Contractor’s superintendent or supervisor for every day management of the project.
- (h) **Record Drawings:** Upon completion of the Work and prior to the final inspection, the Contractor shall deliver to the Architect/Engineer, for review and preparation of the Record Drawings, one complete set of “As-Built Drawings” referred to in the preceding subsection.
- (i) **Close-out and Operations and Maintenance Documents:** Upon completion of the Work and prior to final payment, the Contractor shall deliver to the Architect/Engineer, two complete hard copy sets of the Close-out and Operations and Maintenance Documents as specified in the Project Manual Specifications. Additionally, the Contractor will provide two CDs or other acceptably formatted electronic copy of the abovementioned documents to accompany the hard copy versions. The electronic version will be organized with folders and appropriate hierarchy as to represent the hard copy versions. The documentation found on the electronic version will be in PDF format, or other acceptable format as directed by the Owner.

## 24. SUBMITTALS

- (a) The Contractor shall submit a listing of all Submittals required by the Architect/Engineer or which the Contractor identifies as necessary, fixing the dates for the submission of shop or setting drawings, samples and product data. The listing shall be in a format acceptable to the Architect/Engineer. The Contractor shall identify all Submittals with the Owner’s Project Title as required by Section 2(f). There will be no payments to the Contractor until a listing of all Submittals is submitted and approved by the Architect/Engineer and Owner.
- (b) Submittals shall be forwarded to the Architect/Engineer for approval if required by the specifications or if requested by the Architect/Engineer or the Owner. No part of the Work dealt with by a Submittal shall be fabricated by the Contractor, save at his own risk, until such approval has been given.
- (c) The Contractor shall furnish to the Architect/Engineer for approval the name of the manufacturer, the model number, and other identifying data and information respecting the performance, capacity, nature and rating of the machinery and mechanical and other equipment which the Contractor contemplates incorporating in the Work. When Submittals are required by this Contract for materials, the Contractor shall furnish full information concerning the material or articles which he contemplates incorporating in the Work. When required, samples shall be submitted for approval at the Contractor’s expense, with all shipping charges prepaid. Machinery, equipment, material and articles installed or used without required approval shall be at the risk of subsequent rejection.

- (d) The Owner prefers and encourages the Contractor to submit all shop drawings to the Architect/Engineer electronically. However, shop drawings may be submitted in the form of six (6) blue line or black line prints. Catalog cuts, product data and other non-reproducible literature, except certificates, shall be submitted in six (6) copies minimum, of which three (3) will be retained by the Architect/Engineer and the remainder will be returned to the Contractor.
- (e) The Owner prefers and encourages the Contractor to submit all Submittals to the Architect/Engineer electronically. Submittals shall be accompanied by a letter of transmittal which shall list the Project Title, the Submittals included, the specification section number applicable to each, and the date shown on each Submittal. Submittals shall be complete in every respect and bound in sets if not submitted electronically. Each Submittal shall be clearly marked to show each item, component and/or optional feature proposed to be incorporated into the Project. Cross reference to the plans or specifications as needed to identify the use for which the item or component is intended.
- (f) The Contractor shall check the Submittals for compliance with the requirements of the Contract Documents. The Contractor shall clearly note in writing any and all items which deviate from the requirements of the Contract Documents. Reasons for deviation shall be included with the Submittal. The Contractor shall be solely responsible for checking all dimensions and coordinating all materials and trades to ensure that the components or products proposed, individually or in combination, will fit in the space available and that they will be compatible with other components or products provided.
- (g) After checking each submittal, the Contractor shall stamp each sheet of the Submittal with the Contractor’s review stamp. Data submitted in a bound volume or on one sheet printed on two sides, may be stamped on the front of the first sheet only. The Contractor’s review stamp shall be worded as follows:

The equipment and material shown and marked in this submittal is that proposed to be incorporated into this Project, is in compliance with the Contract drawings and specifications unless otherwise shown in bold face type or lettering and listed on a page or pages headed “DEPARTURES FROM DRAWINGS AND SPECIFICATIONS”, and can be installed in the allocated spaces.

Reviewed by \_\_\_\_\_ Date \_\_\_\_\_

The person signing the review stamp shall be the person designated in writing by the Contractor as having that authority. (A copy of such designation shall be forwarded to the A/E prior to or with the first Submittal.) The signature on the stamped review statement shall be handwritten in ink, or in the case of electronic submittals, electronically signed in accordance with § 59.1-479 et seq. of the Code of Virginia. Stamped signatures are not acceptable.

- (h) The Contractor shall forward all Submittals sufficiently in advance of construction requirements to allow reasonable time for checking, correcting, resubmitting and rechecking.
- (i) If a Submittal indicates a departure from the Contract requirements, the Architect/Engineer may reject the Submittal or, if he deems it to have merit, may recommend it to the Owner, who shall approve or reject it as the Owner, in its sole discretion, sees fit. The departure from the Contract

requirements shall be further authorized by a Change Order, if a reduction or increase in the Contract Price is appropriate.

- (j) The Architect/Engineer is responsible to the Owner, but not to the Contractor, to verify that the Submittals conform to the design concept and functional requirements of the plans and specifications, that the detailed design portrayed in shop drawings and proposed equipment and materials shown in Submittals are of the quality specified and will function properly, and that the Submittals comply with the Contract Documents.
- (k) The Work shall be in accordance with approved Submittals. Approval of the Contractor's Submittals by the A/E does not relieve the Contractor from responsibility of complying with the Contract and all drawings and specifications, except as changed by Change Order.
- (l) The plans and/or specifications may indicate that the Architect/Engineer designed or detailed a portion of the plans around a particular product (most commonly a piece of equipment). Should a different product be proposed by the Contractor and accepted, all modifications, rerouting, relocations and variations required for proper installation and coordination to comply with the design concept and requirements of the Contract Documents shall be the responsibility of the Contractor and shall be made at no extra cost to the Owner. If the plans were noted as designed or detailed around a particular product and/or if a product is named when a "brand name or equal" specification has been used, this is not intended to favor or preclude the use of other products pursuant to Section 26 of these General Conditions. Rather such design merely acknowledges the reality that in many instances the Architect/Engineer must have a basis to design and detail around for dimensions and characteristics of a product or system.
- (m) Additional Submittal requirements may be shown in the specifications.

## **25. FEES, SERVICES AND FACILITIES**

- (a) The Contractor shall obtain all permits and pay for all fees and charges necessary for temporary access and public right-of-way blockage or use, for temporary connections to utilities and for the use of property (other than the Site) for storage of materials and other purposes unless otherwise specifically stated in the Contract Documents.
- (b) Certain projects such as renovations and interior modifications of existing buildings will usually have water and electric service to the building. In those instances, water and electric power, if required for the Work under the Contract, will be furnished by the Owner subject to reasonable use by the Contractor, only to the extent and capacity of present services. The Contractor shall be responsible for providing required connections, temporary wiring, piping, etc. to these services in a safe manner and in accordance with applicable codes. All temporary wire, pipe, etc. shall be removed before the Substantial Completion inspection. Acceptance by the Contractor of the use of Owner's water and electricity constitutes a release to the Owner of all claims and of all liability to the Contractor for whatever damages which may result from power and water outages or voltage variations.
- (c) The Owner shall pay any connection charges for permanent utility connections directly to the utility Supplier. The Contractor shall coordinate such connections with the utility Supplier.

- (d) It is understood that, except as otherwise specifically stated in the Contract Documents, the Contractor, either directly or through his Subcontractors, shall provide and pay for all material, labor, tools, equipment, water, light, power, telephone and other services or facilities of every nature whatsoever necessary to execute completely and deliver the Work within the Contract Time for Completion or before the Contract Completion Date.

## 26. EQUALS

- (a) **Brand names:** Unless otherwise stated in the specifications, the name of a certain brand, make or manufacturer denotes the characteristics, quality, workmanship, economy of operation and suitability for the intended purpose of the article desired, but does not restrict the Contractor to the specific brand, make, or manufacturer; it is set forth to convey to the Contractor the general style, type, character and quality of the article specified.
- (b) **Equal materials, equipment or assemblies:** Whenever in these Contract Documents, a particular brand, make of material, device or equipment is shown or specified, such brand, make of material, device or equipment shall be regarded merely as a standard. Any other brand, make or manufacturer of a product, assembly or equipment which in the opinion of the Architect/Engineer is the equal of that specified, considering quality, capabilities, workmanship, configuration, economy of operation, useful life, compatibility with design of the Work, and suitability for the intended purpose, will be accepted unless rejected by the Owner as not being equal.
- (c) **Substitute materials, equipment or assemblies:** The Contractor may propose to substitute a material, product, equipment, or assembly which deviates from the requirements of the Contract Documents but which the Contractor deems will perform the same function and have equal capabilities, service life, economy of operations, and suitability for the intended purpose. The proposal must include any cost differentials proposed. The Owner will have the A/E provide an initial evaluation of such proposed substitutes and provide a recommendation on acceptability and indicate the A/E's redesign fee to incorporate the substitution in the design. If the proposed substitute is acceptable to the Owner, a Change Order will be proposed to the Contractor to accept the substitute and to deduct the cost of the A/E redesign fee and the proposed cost savings from the Contract Price. The Owner shall have the right to limit or reject substitutions at its sole discretion.
- (d) The Contractor shall be responsible for making all changes in the Work necessary to adapt and accommodate any equal or substitute product which it uses. The necessary changes shall be made at the Contractor's expense.

## 27. AVAILABILITY OF MATERIALS

If a brand name, product, or model number included in the Contract Documents is not available on the present market, alternate equal products or model numbers may be proposed by the Contractor through the Architect/Engineer for approval by the Owner. A letter from the manufacturer or representative of the manufacturer that states the specified brand name product or model number is no longer available is required.

## **28. CONTRACTOR'S TITLE TO MATERIALS**

No materials or supplies for the Work shall be purchased by the Contractor, or by any Subcontractor or Supplier, subject to any security interest, installment or sales contract or any other agreement or lien by which an interest is retained by the seller or is given to a secured party. The Contractor warrants that he has clear and good title to all materials and supplies which he uses in the Work or for which he accepts payment in whole or in part.

## **29. STANDARDS FOR MATERIALS INSTALLATION & WORKMANSHIP**

- (a) Unless otherwise specifically provided in the Contract, all equipment, material, and accessories incorporated in the Work are to be new and in first class condition.
- (b) Unless specifically approved by the Owner or required by the Contract, the Contractor shall not incorporate into the Work any materials known by the industry to be hazardous to the health of building construction workers, maintenance workers, or occupants (for example asbestos or lead paint). If the Contractor becomes aware that a material required by the Contract contains asbestos or other hazardous materials, he shall notify the Owner and the Architect/Engineer immediately and shall take no further steps to acquire or install any such material without first obtaining Owner approval.
- (c) All workmanship shall be of the highest quality found in the building industry in every respect. All items of Work shall be done by craftsmen or tradesmen skilled in the particular task or activity to which they are assigned. In the acceptance or rejection of Work, no allowance will be made for lack of skill on the part of workmen. Poor or inferior workmanship (as determined by the Architect/Engineer, the Owner or other inspecting authorities) shall be removed and replaced at Contractor's expense such that the Work conforms to the highest quality standards of the trades concerned, or otherwise corrected to the satisfaction of the Architect/Engineer, the Owner, or other inspecting authority, as applicable.
- (d) Under the various sections of the plans or specifications, where specified items are supplied with the manufacturer's printed instructions, recommendations, or directions for installation, or where such instructions, recommendations, or directions are available, installation of the specified items shall be in strict accordance with the manufacturer's printed instructions unless those instructions contradict the plans or specifications, in which case the Architect/Engineer will be notified for an interpretation and decision.
- (e) Under the various sections of the plans or specifications, where reference is made to specific codes or standards governing the installation of specified items, installation shall in all cases be in strict accordance with the referenced codes and standards. Where no reference is made to specific codes or standards, installation shall conform to the generally recognized applicable standards for first-class installation of the specific item to be installed. Contractors are expected to be proficient and skilled in their respective trades and knowledgeable of the Codes and Standards of the National Fire Protection Association (NFPA), National Electric Code (NEC), Occupational Safety and Health Act (OSHA) and other codes and standards applicable to installations and associated work by his trade.

- (f) Where the manufacturer's printed instructions are not available for installation of specific items, where specific codes or standards are not referenced to govern the installation of specific items, or where there is uncertainty on the part of the Contractor concerning the installation procedures to be followed or the quality of workmanship to be maintained in the installation of specific items, the Contractor shall consult the Architect/Engineer for approval of the installation procedures or the specific standards governing the quality of workmanship the Contractor proposes to follow or maintain during the installation of the items in question.
  
- (g) During and/or at the completion of installation of any items, the tests designated in the plans or specifications necessary to assure proper and satisfactory functioning for its intended purpose shall be performed by the Contractor or by its Subcontractor responsible for the completed installation. All costs for such testing are to be included in the Contract Price. If required by the Contract Documents, the Contractor shall furnish prior to final inspection the manufacturers' certificates evidencing that products meet or exceed applicable performance, warranty and other requirements, and certificates that products have been properly installed and tested.

### **30. WARRANTY OF MATERIALS AND WORKMANSHIP**

- (a) The Contractor warrants that, unless otherwise specified, all materials and equipment incorporated in the Work under the Contract shall be new, in first class condition, and in accordance with the Contract Documents. The Contractor further warrants that all workmanship shall be of the highest quality and in accordance with the Contract Documents and shall be performed by persons qualified at their respective trades.
- (b) Work not conforming to these warranties shall be considered defective.
- (c) This warranty of materials and workmanship is separate and independent from and in addition to any of the Contractor's other guarantees or obligations in the Contract or under Virginia law.

### **31. USE OF SITE AND REMOVAL OF DEBRIS**

- (a) The Contractor shall:
  - (1) Perform the Work in such a manner as not to interrupt or interfere with the operation of any existing activity on, or in proximity to, the Site or with the Work of any other separate contractor;
  - (2) Store his apparatus, materials, supplies and equipment in such orderly fashion at the Site of the Work as will not unduly interfere with the progress of his Work or the work of any other separate contractor; and
  - (3) Place upon the Work or any part thereof only such loads as are consistent with the safety of that portion of the Work.
- (b) The Contractor expressly undertakes, either directly or through his Subcontractor(s), to effect all cutting, filling or patching of the Work required to make the same conform to the plans and specifications, and, except with the consent of the Architect/Engineer, not to cut or otherwise alter the Work of any other separate contractor. The Contractor shall not damage or endanger any portion of the Work or Site, including existing improvements, unless called for by the Contract.
- (c) The Contractor expressly undertakes, either directly or through his Subcontractor(s), to clean up frequently all refuse, rubbish, scrap materials and debris caused by his operations, to the end that at all times the Site shall present a neat, orderly and workmanlike appearance. No such refuse, rubbish, scrap material and debris shall be left within the completed Work nor buried on the building Site, but shall be removed from the Site and properly disposed of in a licensed landfill or otherwise as required by law.
- (d) The Contractor expressly undertakes, either directly or through his Subcontractor(s), before final payment or such prior time as the Owner may require, to remove all surplus material, false Work, temporary structures, including foundations thereof, plants of any description and debris of every nature resulting from his operations and to put the Site in a neat, orderly condition; to thoroughly clean and leave reasonably dust free all finished surfaces including all equipment, piping, etc., on the interior of all buildings included in the Contract; and to clean thoroughly all glass installed under the

Contract, including the removal of all paint and mortar splatters and other defacements. If the Contractor fails to clean up at the time required herein, the Owner may do so and charge the costs incurred thereby to the Contractor in accordance with Section 10(b) of these General Conditions.

- (e) The Contractor shall have, on-site, an employee certified by the Department of Conservation and Recreation as a Responsible Land Disturber who shall be responsible for the installation, inspection and maintenance of erosion control and stormwater management measures and devices. The Contractor shall prevent Site soil erosion, the runoff of silt and/or debris carrying water from the Site, and the blowing of debris off the Site in accordance with the applicable requirements and standards of the Contract, the County of Albemarle's Water Protection Ordinance, and any Virginia water protection ordinances/codes and/or stormwater regulations. This would include covering of dumpsters during periods of precipitation to prevent any runoff to the stormwater system.

### **32. TEMPORARY ROADS**

Temporary roads, if required, shall be established and maintained until permanent roads are accepted, then removed and the area restored to the conditions required by the Contract Documents. Crushed rock, paving and other road materials from temporary roads shall not be left on the Site unless permission is received from the Owner to bury the same at a location and depth approved by the Owner or leave in place as installed.

### **33. SIGNS**

The Contractor may, at his option and without cost to the Owner, erect signs acceptable to the Owner on the Site for the purpose of identifying and giving directions to the job. No signs shall be erected without prior approval of the Owner as to design and location. The Contractor shall pay all fees required by Albemarle County.

### **34. PROTECTION OF PERSONS AND PROPERTY**

- (a) The Contractor expressly undertakes, both directly and through his Subcontractors, to take every reasonable precaution at all times for the protection of all persons and property which may come on the Site or be affected by the Contractor's Work.
- (b) The Contractor shall be solely responsible for initiating, maintaining and supervising all safety precautions and programs in connection with the Work. Any violation of these requirements or duties or any potential safety hazard that is brought to the attention of the Contractor by the Architect/Engineer, the Owner, or any other persons shall be immediately abated.
- (c) The provisions of all rules and regulations governing health and safety as adopted by the Safety Codes Commission of the Commonwealth of Virginia, issued by the Department of Labor and Industry under Title 40.1 of the Code of Virginia, shall apply to all Work under this Contract.

- (d) The Contractor shall continuously maintain adequate protection of all his Work from damage and shall protect the Owner's property from injury or loss arising in connection with this Contract. He shall make good any such damage, injury or loss, except as may be directly and solely due to errors in the Contract Documents or caused by agents or employees of the Owner. The Contractor shall adequately protect adjacent property to prevent any damage to it or loss of use and enjoyment by its owners. The Contractor shall provide and maintain all passageways, guard fences, lights and other facilities for protection as required by public authority, local conditions, or the Contract.
- (e) In an emergency affecting the health, safety or life of persons or of the Work, or of the adjoining property, the Contractor, without special instruction or authorization from the Architect/Engineer or the Owner, shall act, at his discretion, to prevent such threatened loss or injury. Also, should he, to prevent threatened loss or injury, be instructed or authorized to act by the Architect/Engineer or the Owner, he shall so act immediately, without appeal. Any additional compensation or extension of time claimed by the Contractor on account of any emergency work shall be determined as provided by Section 38 of these General Conditions.
- (f) When necessary for the proper protection of the Work, temporary heating, cooling, humidification, or de-humidification of a type approved by the Architect/Engineer must be provided by the Contractor, at the Contractor's expense, unless otherwise specified.

### **35. CLIMATIC CONDITIONS**

The Contractor shall suspend activity on and protect any portion of the Work that may be subject to damage by climatic conditions, including but not limited to, protection from precipitation, wind (including securing material and equipment that could become airborne), and extreme temperatures.

### **36. PAYMENTS TO CONTRACTOR**

- (a) Unless otherwise provided in the Contract, the Owner will make partial payments to the Contractor on the basis of a duly certified and approved Schedule of Values and Certificate for Payment, Form AC-12, showing the estimate of the Work performed during the preceding calendar month or work period, as recommended by the Architect/Engineer. When evaluating the Contractor's Form AC-12, the Architect/Engineer will consider the value of the Work in place, the value of approved and properly stored materials, the status of the Work on the critical path with regard to the Time for Completion, and the estimated value of the Work necessary to achieve Final Completion. The Architect/Engineer will schedule a monthly pay meeting. The Contractor will submit his monthly estimate of Work completed on Form AC-12 so that it is received by the Architect/Engineer and the Owner's Project Manager at least two work days prior to the date scheduled by the Architect/Engineer for the monthly pay meeting. The Owner will review the estimate with the Architect/Engineer and the Contractor at the monthly pay meeting, which shall be considered the receipt date, and may approve any or all of the estimate of Work for payment. In preparing estimates, the material delivered to the Site and preparatory Work done shall be taken into consideration, if properly documented as required by Section 20 of these General Conditions, or as may be required by the Architect/Engineer so that quantities may be verified. In addition to material delivered to the Site, material such as large pieces of equipment and items purchased specifically for the Project, but stored off the Site within the Commonwealth of Virginia, may be considered for payment, provided

all of the following are accomplished prior to the submission of the monthly payment request in which payment for such materials is requested:

- (1) The Contractor must notify the Owner in writing, at least ten (10) days prior to the submission of the payment request, through the Architect/Engineer, that specific items will be stored off Site in a designated, secured place within the Commonwealth of Virginia. The Schedule of Values must be detailed to indicate separately both the value of the material and the labor/installation for trades requesting payment for stored materials. By giving such notification and by requesting payment for material stored off Site, the Contractor warrants that the storage location is safe and suitable for the type of material stored and that the materials are identified as being the property of the Contractor, and agrees that loss of materials stored off the Site shall not relieve the Contractor of the obligation to timely furnish these types and quantities of materials for the Project and meet the Time for Completion or Contract Completion Date, subject to Section 42(b) of these General Conditions. If the storage location is more than 20 miles from the Site, the Contractor may be required to reimburse the Owner for the cost incurred for travel to the storage location to verify the Contractor's request for payment for materials stored off Site.
- (2) Such notification, as well as the payment request, shall:
  - (a) itemize the quantity of such materials and document with invoices showing the cost of said materials;
  - (b) indicate the identification markings used on the materials, which shall clearly reference the materials to the particular project;
  - (c) identify the specific location of the materials, which must be within reasonable proximity to the Site and within the Commonwealth of Virginia;
  - (d) include a letter from the Contractor's Surety which confirms that the Surety on the Performance Bond and the Labor and Material Payment Bond has been notified of the request for payment of materials stored off the Site and agrees that the materials are covered by the bond; and
  - (e) include a certificate of all-risk builder's risk insurance in an amount not less than the fair market value of the materials, which shall name the Owner and the Contractor as co-insured.
- (3) The Architect/Engineer shall indicate, in writing, to the Owner that Submittals for such materials have been reviewed and meet the requirements of the Contract Documents, that the stored materials meet the requirement of the plans and specifications, and that such materials conform to the approved Submittals. Should the A/E deem it necessary to visit the storage site to make such review, the Contractor shall bear the costs incurred therewith.
- (4) The Owner, through the Architect/Engineer, shall notify the Contractor in writing of its agreement to prepayment for materials.

- (5) The Contractor shall notify the Owner in writing, through the Architect/Engineer, when the materials are to be transferred to the Site and when the materials are received at the Site.
- (b) Payment will not be made for materials or equipment stored on or off the Site which are not scheduled for incorporation into the Work within the six months following submission of the request for payment, unless the Contractor has the prior consent of the Owner, which consent may be granted or withheld by the Owner in its discretion if, in the opinion of the Owner, it is not necessary to procure the materials more than six months in advance of use to assure their availability when needed.
- (c) In making such partial payments, five percent (5%) of each payment to the Contractor shall be retained until Final Completion and acceptance of all Work covered by the Contract, unless otherwise provided by any law, regulation or program of the federal government. Such retainage shall be held to assure faithful performance of the Contract and may also be used as a fund to deduct amounts due to or claimed by the Owner, including, but not limited to, payment to the Owner of all monies due for deductive change orders, credits, uncorrected Defective Work, interest, damages, and the like. (§2.2-4333 of the Code of Virginia)
- (d) All material and Work for which partial payments are made shall thereupon become the sole property of the Owner, but this provision shall not relieve the Contractor from the sole responsibility for all materials and Work, including those for which payment has been made, or for the restoration of any damaged materials or Work. Nor shall this provision serve as a waiver of the right of the Owner to require the fulfillment of all of the terms and conditions of the Contract.
- (e) The final payment, which shall include the retainage, less any amounts due to or claimed by the Owner, shall not become due until the Architect/Engineer and the Owner agree that Final Completion has been achieved and until the Contractor shall deliver to the Owner through the Architect/Engineer a Certificate of Completion by the Contractor (Form AC-13.2) and an Affidavit of Payment of Claims (Form AC-13), stating that all Subcontractors and Suppliers of either labor or materials have been paid all sums claimed by them for Work performed or materials furnished in connection with this Project less retainage. Amounts due the Owner which may be withheld from the final payment may include, but are not limited to, amounts due pursuant to Section 3(i), Section 16(a)-(d), Section 31(d), costs incurred to repair or replace Defective Work, costs incurred as a result of the Contractor's negligent acts or omissions or omissions of those for whom the Contractor is responsible, delay damages under Section 42(h), and any liquidated or actual damages. If all Subcontractors and Suppliers of labor and materials have not been paid the full amount claimed by them, the Contractor shall list each to which an agreed amount of money is due or which has a claim in dispute. With respect to all such Subcontractors and Suppliers, the Contractor shall provide to the Owner, along with the Affidavit of Payment of Claims (Form AC-13), an affidavit from each such Subcontractor and Supplier stating the amount of their subcontract or supply contract, the percentage of completion, the amounts paid to them by the Contractor and the dates of payment, the amount of money still due if any, any interest due the Subcontractor or Supplier pursuant to Section 37(b) below, and whether satisfactory arrangements have been made for the payment of said amounts. If no agreement can be reached between the Contractor and one or more Subcontractors or Suppliers as to the amounts owed to the Subcontractors or Suppliers, the Owner may, in its discretion, pay such portion of the monies due to the Contractor which is claimed by the Subcontractor or Supplier into a Virginia Court or Federal Court sitting in Virginia, in the manner provided by law. Said payment into court shall be deemed a payment to the Contractor. Nothing in this Section shall be construed as creating any obligation or contractor relationship between the Owner and any Subcontractor or Supplier, and the

Owner shall not be liable to any Subcontractor or Supplier on account of any failure or delay of the Owner in complying with the terms hereof.

- (f) Upon successful completion of the final inspection and all Work required by the Contract, including but not limited to the delivery of As-Built drawings, equipment manuals, written warranties, acceptance of the Work by the Owner and the delivery of the affidavits required in Section 36(e) of these General Conditions, the Architect/Engineer shall deliver the written Certificate of Completion by the Architect/Engineer (Form AC-13.1) to the Owner, with a copy to the Contractor, stating the entire amount of Work performed and compensation earned by the Contractor, including extra work and compensation therefor. The Owner may accept the Work for occupancy or use while asserting claims against the Contractor; disputing the amount of compensation due to the Contractor; disputing the quality of the Work, its completion, or its compliance with the Contract Documents; or any other reason.
- (g) Unless there is a dispute about the compensation due to the Contractor, Defective Work, quality of the Work, compliance with the Contract Documents, completion itself, claims by the Owner, other matters in contention between the parties, or unless monies are withheld pursuant to Albemarle County's Debt Setoff Program, within thirty (30) days after receipt and acceptance of the Schedule of Values and Certificate for Payment (Form AC-12) in proper form by the Architect/Engineer at the monthly pay meeting, which shall be considered the receipt date, the Owner shall pay to the Contractor the amount approved by the Architect/Engineer, less all prior payments and advances whatsoever to or for the account of the Contractor. In the case of final payment, the completed Affidavit of Payment of Claims (Form AC-13), the Certificate of Completion by the Contractor (Form AC-13.2) and the Certificate of Completion by the Architect/Engineer (Form AC-13.1) shall accompany the final Schedule of Values and Certificate for Payment (Form AC-12) which is forwarded to the Owner for payment. The date on which payment is due shall be referred to as the Payment Date. In the event of disputes, payment shall be mailed on or before the Payment Date for amounts and Work not in dispute, subject to any set offs claimed by the Owner, provided however, in instances where further appropriations are required by the County of Albemarle or where the issuance of further bonds is required, in which case, payment shall be made within thirty (30) days after the effective date of such appropriation or within thirty (30) days after the receipt of bond proceeds by the Owner. All prior estimates and payments including those relating to extra Work may be connected and adjusted in any payment and shall be corrected and adjusted in the final payment. In the event that any request for payment by the Contractor contains a defect or impropriety, the Owner shall notify the Contractor of any defect or impropriety which would prevent payment by the Payment Date, within five (5) days after receipt of the Schedule of Values and Certificate for Payment (Form AC-12) by the Owner from the Architect/Engineer.
- (h) Interest shall accrue on all amounts owed by the Owner to the Contractor which remain unpaid seven (7) days following the Payment Date. Said interest shall accrue at the discounted ninety-day U.S. Treasury bill rate as established by the Weekly Auction and as reported in the publication entitled The Wall Street Journal on the weekday following each such Weekly Auction. During the period of time when the amounts due to the Contractor remain unpaid following the seventh (7th) day after the Payment Date, the interest accruing shall fluctuate on a weekly basis and shall be that established by the immediately prior Weekly Auction. It shall be the responsibility of the Contractor to gather and substantiate the applicable weekly interest rates to the satisfaction of the Owner and to calculate to the satisfaction of the Owner the interest due. In no event shall the rate of interest charge exceed the rate of interest charged pursuant to §58.1-1812 of the Code of Virginia. No interest shall accrue on

retainage or when payment is delayed because of disagreement between the Owner and the Contractor regarding the quantity, quality or timeliness of the Work, including, but not limited to, compliance with Contract Documents or the accuracy of any Request for Payment received. This exception to the accrual of interest stated in the preceding sentence shall apply only to that portion of a delayed payment which is actually the subject of such a disagreement and shall apply only for the duration of such disagreement. Nothing contained herein shall be interpreted, however, to prevent the withholding of retainage to assure faithful performance of the Contract. These same provisions relating to payment of interest to the Contractor shall apply also to the computation and accrual of interest on any amounts due from the Contractor to the Owner for deductive change orders and to amounts due on any claims by the Owner. The date of mailing of any payment by the U.S. Mail is deemed to be the date of payment to the addressee.

- (i) The acceptance by the Contractor of the final payment shall be and operate as a release to the Owner of all claims by the Contractor, its Subcontractors and Suppliers, and of all liability to the Contractor whatever, including liability for all things done or furnished in connection with this Work, except for things done or furnished which are the subject of unresolved claims for which the Contractor has filed a timely written notice of intent, provided a claim is submitted no later than sixty (60) days after final payment. Acceptance of any interest payment by the Contractor shall be a release of the Owner from claims by the Contractor for late payment.
- (j) No certificate for payment issued by the Architect/Engineer, and no payment, final or otherwise, no certificate of completion, nor partial or entire use or occupancy of the Work by the Owner, shall be an acceptance of any Work or materials not in accordance with the Contract, nor shall the same relieve the Contractor of responsibility for faulty materials or Defective Work or operate to release the Contractor or his Surety from any obligation under the Contract, the Standard Performance Bond and the Standard Labor and Material Payment Bond.

### **37. PAYMENTS BY CONTRACTOR (§2.2-4354, Code of Virginia)**

Under §2.2-4354, Code of Virginia, the Contractor is obligated to:

- a. This is a construction contract under the VPPA. Therefore, Contractor shall pay all subcontractors in the manner provided in Virginia Code Section 2.2-4354(1).
- b. Contractor shall pay all subcontractors in the manner provided in Virginia Code Section 2.2-4354(2-5).

### **38. CHANGES IN THE WORK**

- (a) The Owner may at any time, by written order utilizing the County of Albemarle Change Order Form AC-11, and without notice to the sureties, make changes in the Work which are within the general scope of the contract except that no change will be made which will increase the total Contract Price to an amount more than twenty-five percent (25%) in excess of the original Contract Price without notice to sureties. The Owner, at its discretion, may require the Contractor to provide evidence of current surety coverage based on approved changes in the work that result in a change in the total contract amount. At the time of the Preconstruction Meeting described in Section 49(b), the Contractor and the Owner shall advise each other of their designees authorized to accept and/or

approve changes to the Contract Price and of any limits to each designee's authority. Should any designee or limits of authority change during the time this Contract is in effect, the Contractor or Owner shall give written notice to the other within seven (7) calendar days, utilizing the procedures set forth in these General Conditions. The Contractor agrees and understands that the authority of the Owner's designee is limited by Virginia Code §2.2-4309 and any other applicable statute.

If the Contractor claims that any instructions given to him by the Architect/Engineer or by the Owner, by drawings or otherwise, involve extra Work which increases the scope of the Contract, then, except in emergencies endangering life or property, he shall give the Architect/Engineer and the Owner written notice thereof before proceeding to execute the Work. Said notice shall be given promptly enough to avoid delaying the Work and in no instance later than fourteen (14) days after the receipt of such instructions. Should it not be immediately clear to the Contractor that the change involves extra Work outside the scope of the Contract, written notice shall be sufficient if given as soon as possible after such realization, but in no event later than fourteen (14) days after the start of such Work. If the Owner agrees, a Change Order shall be issued as provided herein, and any additional compensation shall be determined by one of the four (4) methods provided herein, as selected by the Owner. Except as otherwise specifically provided, no claims for extra Work shall be allowed unless timely notice, as required by this Section, is given by the Contractor and unless such Work is performed pursuant to written Change Order. In making any change, the charge or credit for the change shall be determined by one of the following methods as selected by the Owner:

- (1) **Fixed Price:** By a mutually agreed fixed amount change to the Contract Price and/or time allowed for completion of the Work. By using the Estimate for Change Order Forms GC-1, SC-1, and SS-1, respectively, the Change Order shall be substantiated by documentation itemizing the estimated quantities and actual costs of all labor, materials and equipment required as well as any markup used. The price change shall include the Contractor's overhead and profit. See Subsections (d) and (e) below.
- (2) **Unit Price:** By using unit prices and calculating the number of net units of Work in each part of the Work which is changed, either as the Work progresses or before Work on the change commences, and by then multiplying the calculated number of units by the applicable unit price set forth in the Contract or multiplying by a mutually agreed unit price if none was provided in the Contract. No additional percentage markup for overhead or profit shall be added to the unit prices.
- (3) **Unilateral:** If the Owner and Contractor are unable to agree that an item of Work or service constitutes a change, or that Contractor is entitled to additional compensation and/or an extension of time for such item of Work or service, the Contractor, upon receipt of a Unilateral Change Order, signed by the Owner, will promptly proceed with and expeditiously perform and/or supply the item of Work or service. If the parties are unable to agree on the amount of adjustment or schedule, the Owner will provide written notification to the Contractor of the adjustment the Owner considers appropriate. Such adjustment will be effective subject to Contractor's right to submit a claim as provided in Section 46. Any claim for an adjustment of compensation or schedule, or in opposition to an adjustment imposed by the Owner, will be submitted to the Owner in writing within seven (7) days of commencement of the event giving rise to such claim. The Contractor will submit to the Owner, in writing, the amount of the claim with supporting data within thirty (30) days of completion of the services or termination of the event for which it claims an adjustment.

- (4) **Cost Reimbursement (Time and Materials):** In order to allow performance of services to proceed in a timely manner, the Owner may issue a written order for the Contractor to proceed with a change for additional work or service in anticipation of subsequently negotiating an agreeable adjustment of the Contractor's compensation and/or schedule. Upon completion of the Work, the Contractor, by using Estimate for Change Order Forms GC-1, SC-1, and SS-1, respectively, will present to the Owner, an accurate, itemized account of the cost of the change in the Work, including, but not limited to, the costs of labor, materials, equipment, and supplies; and to annotate a copy of the Project schedule to accurately show the status of the Work at the time this initial written order is issued, to show the start and finish of the changed Work, and the status of the Work when the changed Work is completed.

Except as otherwise may be agreed to in writing by the Owner, such costs shall not exceed those prevailing for the trades or crafts, materials, and equipment in the locality of the Project, may include only those items listed as allowable in Subsection 38(e), and shall not include any of the costs listed as not allowable in Subsection 38(f). The Owner shall be permitted, on a daily basis, to verify such records and may require such additional records as are necessary to determine the cost of the change to the Work.

Within fourteen (14) days of the conclusion of such ordered Work, the Contractor and the Owner shall arrive at a cost for the Change Order Request, based on the records kept and the Contractor's allowance for overhead and profit as set forth in Subsections (d), (e) and (f) below, and such costs shall be incorporated into a Change Order. If agreement on the cost of the changed Work cannot be reached within the fourteen (14) days allotted, the Contractor may file a claim for the disputed amount as provided for in Section 46.

- (b) The Contractor shall review any Owner requested or directed change and shall respond in writing within fourteen (14) calendar days after receipt of the proposed change (or such other reasonable time as the Owner may direct), stating the effect of the proposed change upon his Work, including any increase or decrease in the Contract time and Price. The Contractor shall furnish to the Owner an itemized breakdown of the quantities and prices used in computing the proposed change in Contract Price.

The Owner shall review the Contractor's proposal and respond to the Contractor within thirty (30) days of receipt. If a change to the Contract Price and time for performance are agreed upon, both parties shall sign the Change Order. If the price and time are not agreed upon, the Owner may direct the Contractor to proceed under Subsection 38(a)(3) or 38(a)(4). Changes to the Contract time and/or Price shall be effective when signed by both parties, with the exception of a Unilateral Change Order that is only signed by the Owner.

- (c) In figuring changes, any instructions for measurement of quantities set forth in the Contract shall be followed.
- (d) The percentage for overhead and profit to be used in calculating both additive and deductive changes in the Work (other than changes covered by unit prices) shall not exceed the percentages for each category listed below. Said percentages for overhead and profit shall be applied only on the cost of the changed Work (i.e. difference in cost between original and revised Work):

- (1) If a Subcontractor does all or part of the changed Work, the Subcontractor's markup for overhead and profit on the Work it performs shall be a maximum of ten percent (10%). The Contractor's markup on the subcontractor's price shall be a maximum of ten percent (10%).
  - (2) If the Contractor does all or part of the changed Work, its markup for overhead and profit on the changed Work it performs shall be a maximum of ten percent (10%).
  - (3) If a Sub-subcontractor at any tier does all or part of the changed Work, the Sub-subcontractor's markup on that Work shall be a maximum of ten percent (10%). The markup of a sub-subcontractor's Work by the Contractor and all intervening tiers of Subcontractors shall not exceed a total of ten percent (10%).
  - (4) Where Work is deleted from the Contract prior to commencement of that Work without substitution of other similar Work, one hundred percent (100%) of the Contract Price attributable to that Work shall be deducted from the Contract Price including applicable overhead costs and profit. However, in the event that material Submittals have been approved and orders placed for said materials, a lesser amount, but in no case less than eighty percent (80%) of the Contract Price attributable to that Work, shall be deducted from the Contract Price. The credit to the Owner for reduced premiums on labor and material bonds and performance bonds shall in all cases be one hundred percent (100%).
- (e) Allowable costs for changes in the Work may include the following:
- (1) Labor costs for employees directly employed in the change in the Work, including actual salaries and wages plus the cost of payroll charges and fringe benefits and overtime premiums, if such premiums are explicitly authorized by the Owner. "Billable" or "loaded" labor or wage rates will not be accepted.
  - (2) Materials incorporated into the change to the Work, including costs of transportation and storage, if applicable. If applicable, all cash discounts shall accrue to the Contractor, unless the Owner deposits funds with the Contractor to make such payments, and all trade discounts, rebates, refunds, and returns from the sale of surplus materials shall accrue to the Owner.
  - (3) Equipment incorporated in the changed Work or equipment used directly in accomplishing the Work. If rented expressly for accomplishing the change in the Work, the cost shall be the rental rate according to the terms of the rental agreement, which the Owner shall have the right to approve. If owned by the Contractor, the costs shall be a reasonable price based upon the life expectancy of the equipment and the purchase price of the equipment. If applicable, transportation costs may be included.
  - (4) Costs of increases in premiums for the Standard Labor and Material Payment Bond and the Standard Performance Bond, provided coverage for the cost of the change in the Work results in such increased costs. At the Owner's request, the Contractor shall provide proof of his notification to the Surety of the change in the Work and of the Surety's agreement to include such change in its coverage. The cost of the increase in premium shall be an allowable cost but shall not be marked up.
  - (5) Contractor and Subcontractor overhead costs as set forth in Subsection (d) markups above.

- (6) If the change in the Work also changes the Time for Completion or Contract Completion Date by adding days to perform the Work, an itemized accounting of the following Site direct overhead expenses for the change to the time may be considered as allowable costs for compensation in addition to those shown above: The Site superintendent's prorata salary, temporary Site office trailer expense, and temporary Site utilities including basic telephone service, electricity, heat, water, and sanitary/toilet facilities. All other direct and indirect overhead expenses are considered covered by and included in the Subsection (d) markups above.
  - (7) Any other costs directly attributable to the change in the Work with the exception of those set forth below.
- (f) Allowable costs for changes in the Work shall not include the following:
- (1) Costs due to the negligence of the Contractor, any Subcontractor, Supplier, their employees or other persons for whom the Contractor is responsible, including, but not limited to, costs for the correction of Defective Work, for improper disposal of material, for equipment wrongly supplied, for delay in performing the Work, or for delay in obtaining materials or equipment.
  - (2) Home office expenses including payroll costs for the Contractor's officers, executives, administrators, project managers, accountants, counsel, engineers, timekeepers, estimators, clerks, and other similar administrative personnel employed by the Contractor, whether at the Site or in the Contractor's principal or branch office for general administration of the Work. These costs are deemed overhead included in the percentage markups allowable in Subsection (d) above.
  - (3) Home and field office expenses not itemized in Subsection 38(e)(6) above. Such items include, but are not limited to, expenses of Contractor's home and branch offices, Contractor's capital expenses, interest on Contractor's capital used for the Work, charges for delinquent payments, small tools, incidental job costs, meals, rent, utilities, telephone and office equipment, and other general overhead expenses.
- (g) All Change Orders must state that the Contract Time for Completion or Contract Completion Date is not changed or is either increased or decreased by a specific number of days. The old Time for Completion and, if changed, the new Time for Completion must be stated.

If the Contractor requests an extension to the Time for Completion or a later Contract Completion Date, he must provide written justification for the extension to the Architect/Engineer and to the Owner. The written justification must demonstrate an anticipated actual increase in the time required to complete the Work beyond that allowed by the Contract as adjusted by prior change orders or amendments to the Contract, not just an increase or decrease in the time needed to complete some portion of the total Work. When a CPM schedule is required by the Contract, no extension to the Time for Completion or Contract Completion Date shall be allowed unless, and then only to the extent that, the additional or changed Work increases the length of the critical path beyond the Time for Completion or Contract Completion Date. If approved, the increase in time required to complete the Work shall be added to the Time for Completion or Contract Completion Date.

The Owner may decrease, by Change Order, the Time for Completion or Contract Completion Date when an Owner-requested deletion from the Work results in a decrease in the actual time required to complete the Work as demonstrable on the Bar Graph Schedule or on the CPM Schedule, whichever is appropriate. The Contractor may submit a request to decrease, by Change Order, the Time for Completion or Contract Completion Date under the procedures and subject to the considerations set forth in Section 19(g). No request for such decrease shall be considered for approval unless the proposed shorter schedule is otherwise acceptable under Sections 19(b) or (c), whichever is applicable. The Change Order decreasing the Time for Completion or changing the Contract Completion Date must be signed by both the Owner and the Contractor.

With the exception of Change Orders under Subsection 38(a)(4), which shall arrive at a change to the Contract Price and any change to time using the procedures set forth therein, each Change Order shall include all time and monetary impacts of the change, whether the Change Order is considered alone or with all other changes during the course of the Project. Failure to include a change to time and Contract Price in Section 38(a)(1) or (2) Change Orders shall waive any change to the time and Contract Price unless the parties mutually agree in writing to postpone a determination of the change to time and price resulting from the Change Order. Such a determination may be postponed not more than forty-five (45) days to give the Contractor an opportunity to demonstrate a change in the time and price needed to complete the Work. During any such postponement, the Work shall proceed, unless the Owner agrees otherwise.

If at any time there is a delay in the critical path of the Work due to postponement, due to the Contractor's efforts to justify an extension of the time or an increase in the Contract Price, or due to the Contractor's refusal to proceed with any of the Work, pending agreement on a change in time or price, such delay and any Contractor costs resulting from it shall not serve as the basis for the extension of the Time for Completion or Contract Completion Date or for an increase in the Contract Price.

- (h) The acceptance by the Contractor of any payment made by the Owner under a Change Order shall be and operate as a release to the Owner of all claims by the Contractor and of all liability owing to the Contractor for all things done or furnished in connection with the Work described in the Change Order. The execution of any Change Order by the Owner shall not be an acceptance of any Work or materials not in accordance with the Contract Documents, nor shall it relieve the Contractor of responsibility for faulty materials or workmanship or operate to release the Contractor or his surety from any obligation arising under the Contract or the Standard Performance Bond or Standard Labor and Material Payment Bond.
- (i) Payments will not be made for any Work, labor or materials on a fixed price, unit price or Subsection 38(a)(4) basis until the Contractor has furnished the Owner documents, certified as true and correct by an authorized officer or agent of the Contractor, evidencing the cost of such Work, labor and materials. The Owner may require any or all of the following documentation to be provided by the Contractor:
  - (1) certified payroll records showing the name, classification, date, daily hours, total hours, rate, and extension for each laborer, foreman, supervisor or other worker;
  - (2) equipment type & model, dates, daily hours, total hours, rental rate or other specified rate, and extension for each unit of equipment;

- (3) invoices for materials showing quantities, prices, and extensions;
- (4) daily records of waste materials removed from the Site and/or fill materials imported to the Site;
- (5) certified measurements of over excavations, piling installed and similar work; and/or
- (6) transportation records for materials, including prices, loads, and extensions.

Requests for payment shall be accompanied and supported by invoices for all materials used and for all transportation charges claimed. If materials come from the Contractor's own stock, then an affidavit may be furnished, in lieu of invoices, certifying quantities, prices, etc. to support the actual cost.

### **39. CONTRACTOR'S RIGHT TO STOP WORK OR TERMINATE THE CONTRACT**

If the Work should be stopped under an order of any court or other public authority for a period of ninety (90) days through no fault of the Contractor or anyone employed by him, or if the Owner should fail to pay to the Contractor within sixty (60) days any sum certified by the Architect/Engineer when no dispute exists as to the sum due or any provision of the Contract, then the Contractor may, upon ten (10) calendar days written notice to the Owner and the Architect/Engineer, stop Work or terminate the contract and recover from the Owner payment for the cost of the Work actually performed, together with overhead and profit thereon, but profit on the Work performed shall be recovered only to the extent that the Contractor can demonstrate that he would have had profit on the entire Contract if he had completed the Work. The Contractor may not receive profit or any other type of compensation for parts of the Work not performed. The Contractor may recover the reasonable cost of physically closing down the Site, but no other costs of termination. The Owner may offset any claims it may have against the Contractor against the amounts due to the Contractor. In no event shall termination of the Contract by the Contractor terminate the obligations of the Contractor's surety on its payment and performance bonds.

### **40. OWNER'S RIGHT TO STOP WORK OR TERMINATE THE CONTRACT FOR CAUSE**

- (a) If the Contractor should be adjudged as bankrupt, or if he should make a general assignment for the benefit of his creditors, or if a receiver should be appointed on account of his insolvency, the Owner may stop work or terminate the Contract. If the Contractor should refuse or should repeatedly fail, except in cases for which extension of time is provided, to supply enough properly skilled workmen or proper materials and equipment, or if he should fail to make prompt payment to Subcontractors or Suppliers of material or labor, or if he should disregard laws, ordinances or the written instructions of the Architect/Engineer or the Owner, or otherwise be in substantial violation of any provision of the Contract, then the Owner may stop work or terminate the Contract.
- (b) Prior to termination of the Contract, the Owner shall give the Contractor and his surety ten (10) calendar days written notice pursuant to Section 1 ("Notice") of these General Conditions, during which the Contractor and/or his surety may rectify the basis for the notice. If rectified to the satisfaction of the Owner within said ten (10) days, the Owner may rescind its notice of termination. If not, the termination for cause shall become effective at the end of the ten (10) day notice period.

In the alternative, the Owner may, in writing, postpone the effective date of the termination for cause, at its sole discretion, if it should receive reassurances from the Contractor and/or its surety that the basis for the termination will be remedied in a time and manner which the Owner finds acceptable. If at any time after such postponement, the Owner determines that Contractor and/or its surety has not or is not likely to rectify the causes of termination in an acceptable manner or within the time allowed, then the Owner may immediately terminate the Contract for cause, without the necessity of further ten (10) day notice, by notifying the Contractor and his surety in writing of the termination. In no event shall termination for cause terminate the obligations of the Contractor's surety on its payment and performance bonds.

- (c) Upon termination of the Contract, the Owner shall take possession of the Site and of all materials, tools and equipment thereon and finish the Work by whatever method he may deem expedient. In such case the Contractor shall not be entitled to receive any further payment. If the expense of finishing the Work, including compensation for additional managerial and administrative services, shall exceed the unpaid balance of the Contract Price, the Contractor shall pay the difference to the Owner, together with any other expenses of terminating the Contract and having it completed by others.
- (d) If it should be judicially determined that the Owner improperly terminated this Contract for cause, then the termination shall be deemed to be a termination for the convenience of the Owner.
- (e) Termination of the Contract under this Section is in addition to and without prejudice to any other right or remedy of the Owner. Any actions by the Owner permitted herein shall not be deemed a waiver of any other right or remedy of the Owner under the Contract or under the law. The Owner may offset any claims it may have against the Contractor against the amounts due to the Contractor. The provisions of this Section shall survive termination of the Contract.

#### **41. TERMINATION BY OWNER FOR CONVENIENCE**

- (a) Owner may terminate this Contract, in whole or in part, at any time without cause upon giving the Contractor written notice of such termination pursuant to Section 1 ("Notice") of these General Conditions. Upon such termination, the Contractor shall immediately cease Work and remove from the Site all of its labor forces and such of its materials as Owner elects not to purchase or to assume in the manner hereinafter provided. Upon such termination, the Contractor shall take such steps as Owner may require to assign to the Owner the Contractor's interest in all Subcontracts and purchase orders designated by Owner. After all such steps have been taken to Owner's satisfaction, the Contractor shall receive as full compensation for termination and assignment the following:
  - (1) All amounts then otherwise due under the terms of this Contract;
  - (2) Amounts due for Work performed in accordance with the Contract subsequent to the latest approved Schedule of Values and Certificate for Payment (Form AC-12) through the date of termination;
  - (3) Reasonable compensation for the actual cost of demobilization incurred by the Contractor as a direct result of such termination. The Contractor shall not be entitled to any compensation or damages for lost profits or for any other type of contractual compensation or damages other

than those provided by the preceding sentence. Upon payment of the foregoing, Owner shall have no further obligations to Contractor of any nature.

- (b) In no event shall termination for the convenience of the Owner terminate the obligations of the Contractor's surety on its payment and performance bonds.

## **42. DAMAGES FOR DELAYS; EXTENSION OF TIME**

- (a) If the Contractor is delayed at any time in the progress of the Work by any act or omission of the Owner, its agents or employees or any separate independent contractor of the Owner, and the act or omission is the result of or is necessitated by causes outside the Owner's control; or if the Contractor is delayed by strikes, fires, unusual delays in transportation or unavoidable casualties, or other causes outside the Owner's or Contractor's control, the Contractor shall give the Owner and Architect/Engineer written notice within five (5) days of the inception of the delay. The Owner shall extend the time for Substantial Completion or Final Completion, as the case may be, for the length of time that the Substantial Completion or Final Completion of the Work was actually delayed thereby, and the Contractor shall not be charged with liquidated or actual damages for delay during the period of such extension nor shall the Contractor be due compensation or damages of any kind, under any theory of law, as a result of such delay, the impact of such delay, or acceleration of Work as a result of such delay. In the event a CPM schedule is required by the Contract, no extension of the time allowed for Substantial Completion shall be granted unless the Contractor demonstrates a delay in the critical path of the approved CPM schedule or approved bar graph schedule.
- (b) If the Contractor is delayed at any time in the progress of the Work by any act or omission of the Owner, its agents or employees, due to causes within their control, or delayed by the Owner's separate, independent contractors, when such delay results from causes within the Owner's control, and the Contractor intends to seek additional compensation for damages, if any, caused by the delay, the Contractor shall inform the Owner and the Architect/Engineer immediately at the time of the occurrence giving rise to the delay by the fastest means available and shall give written notice no later than five (5) days after inception of the delay. The Contractor's notice to the Owner shall specify the nature of the delay claimed by the Contractor, the cause of the delay and the impact of the delay on the Contractor's Work schedule. The Owner shall then have five (5) days to respond to the Contractor's notice with a resolution, remedy or direction to alleviate the delay or with a notice rejecting the claim for delay alleged to be caused by the Owner or parties for whom the Owner is responsible. If the issue is not then resolved, the Contractor may submit a request for Change Order in accordance with Section 38 or submit a claim as provided for in Section 46. The Contractor shall only be entitled to additional compensation if the delay was unreasonable and was caused solely by acts or omissions of the Owner, its agents or employees, due to causes within their control, or was caused by the Owner's separate, independent contractor, when such delay resulted solely from causes within the Owner's control.
- (c) The Contractor shall not be entitled to an extension of the Time for Completion or Contract Completion Date or to any additional compensation for delays caused by acts or omissions of the Contractor due to causes within his control, including, but not limited to, delays resulting from Defective Work including workmanship and/or materials, from rejected work which must be corrected before dependent work can proceed, from Defective Work or rejected work for which

corrective action must be determined before like work can proceed, or from incomplete, incorrect or unacceptable submittals or samples.

- (d) No extension of time or additional compensation, if applicable, will be granted for any delay unless the claimed delay directly affects the critical path of the approved CPM schedule or the schedule shown on the approved bar graph schedule, whichever is applicable, and any float has been consumed. No extension of time or additional compensation shall be given for a delay if the Contractor failed to give notice in the manner and within the time prescribed in Subsections (a) or (b) above, whichever applies. Furthermore, no extension of time or additional compensation shall be given for any delay unless a claim therefor is made in writing to the Owner, with a copy to the Architect/Engineer, within twenty (20) days of the end of the delay. The claim shall state the cause of the delay, the number of days of extension requested and any compensation requested by the Contractor. The Contractor shall report the termination of the delay to the Owner and Architect/Engineer not less than ten (10) days after such termination. Failure to give notice of either the inception or the termination of the cause of delay or failure to present a claim for extension of time and/or monetary compensation within the times prescribed shall constitute a waiver of any claim for extension or additional compensation based upon that cause.
- (e) Requests for compensation for delays pursuant to Subsection (b) above must be substantiated by itemized data and records clearly showing that the Work delayed was on the critical path of the **approved** CPM schedule or on the sequence of Work on the **approved** bar graph schedule, as modified, and that the additional costs incurred by the Contractor are directly attributable to the delay in the Work claimed. Furthermore, compensation for delay shall be calculated from the contractual Time for Completion or Contract Completion Date, as adjusted by Change Order, and shall not be calculated based on any early completion planned or scheduled by the Contractor, unless a Change Order has been executed pursuant to Section 19(g) changing the Time for Completion or the Contract Completion Date to reflect such early completion. See Section 19 for procedures for the Contractor to follow if he plans early completion of the Work and wishes to request a Change Order reflecting the early completion date.

If there is an extension in the Time for Completion or the Contract Completion Date and if the Contractor is entitled to compensation under Subsection 42(b), and where there is no change in the Work, an itemized accounting of the following direct Site overhead expenses will be considered as allowable costs to be used in determining the compensation due the Contractor:

Site superintendent prorata salary, temporary Site office expense, temporary Site facilities, and temporary Site utilities including basic telephone service, electricity, heat, water, and sanitary/toilets. A ten percent (10%) markup of these expenses will be allowed to compensate the Contractor for home office and other direct or indirect overhead expenses.

- (f) If the Contractor submits a claim for delay damages pursuant to Subsection 42(b) above, the Contractor shall be liable to the Owner for a percentage of all costs incurred by the Owner in investigating, analyzing, negotiating and litigating the claim, which percentage shall be equal to the percentage of the Contractor's total delay claim that is determined through litigation to be false or to have no basis in law or in fact. (§2.2-4335(C), Code of Virginia.)

- (g) Any change in the Contract Time for Completion or Contract Completion Date shall be accomplished only by issuance of a Change Order.
- (h) If the Contractor fails to complete the Work within the Time for Completion or the Contract Completion Date, the Contractor shall be liable to the Owner in the amounts set forth in the Supplemental General Conditions, if any, not as a penalty, but as fixed, agreed and liquidated damages for delay until the Work is substantially or finally completed as the case may be. If liquidated damages are not so fixed in the Supplemental General Conditions, the Contractor shall be liable for any and all actual damages sustained as a result of delay. In addition to damages for delay, whether liquidated or actual, the Contractor shall also be liable for any and all actual damages sustained by the Owner as a result of any other breach of the Contract, including, but not limited to, Defective Work and abandonment of the Contract.
- (i) If liquidated damages are provided by the Supplemental General Conditions, the following provisions apply:
  - (1) If the Work is not substantially complete by the Time for Completion or Contract Completion Date, the Contractor shall owe to the Owner, not as a penalty but as Step One liquidated damages, the sum stated in the Supplemental General Conditions for Step One liquidated damages for each and every partial or total calendar day of delay in Substantial Completion.
  - (2) Once the Work is substantially complete, the accrual of Step One liquidated damages shall cease and the Contractor shall have thirty (30) calendar days, unless otherwise specified in the Contract Documents, in which to achieve Final Completion of the Work.
  - (3) If Final Completion of the Work is not achieved on or before the thirtieth (30th) calendar day, or the date specified in the Contract Documents, after Substantial Completion, and if the Owner has not granted any extension of time, the Contractor shall owe to the Owner, not as a penalty but as Step Two liquidated damages, the sum stated in the Supplemental General Conditions as Step Two liquidated damages for each and every partial or total calendar day of delay in Final Completion.

#### **43. INSPECTION FOR SUBSTANTIAL COMPLETION & FINAL COMPLETION**

- (a) The Contractor shall notify the Owner, in writing on the Certificate of Partial or Substantial Completion by the Contractor (Form AC-13.2a), of the date when the Work or designated portion thereof, will be, in his opinion, substantially complete and ready for inspection and testing to determine if it has reached Substantial Completion. The notice shall be given at least ten (10) days in advance of said date and shall be forwarded through the Architect/Engineer, who will attach his written endorsement as to whether or not he concurs with the Contractor's statement that the Work will be ready for inspection and testing on the date given. The Architect/Engineer's endorsement is a convenience to the Owner only and shall not relieve the Contractor of his responsibility in the matter nor shall the Architect/Engineer's endorsement be deemed to be evidence that the Work was substantially complete and ready for inspection and testing. Inspection and testing shall take place at a time(s) mutually agreeable to the Contractor, Owner and Architect/Engineer.

The inspection shall include a demonstration by the Contractor that all equipment, systems and operable components of the project function properly and in accordance with the Contract Documents. The Contractor shall furnish access for the inspection and testing as provided in Section 21 of these General Conditions. The inspection and testing shall determine whether Substantial Completion has been accomplished and shall result in a written list of unfinished Work and Defective Work, commonly referred to as a “punch list”, which must be finished and corrected to obtain Final Completion.

After successful completion of the testing and the Architect/Engineer determines that, in its opinion, the Work, either in whole or in part, is substantially complete, the Architect/Engineer shall notify the Owner, in writing on the Certificate of Partial or Substantial Completion by the Architect/Engineer (Form AC-13.1a), that the Work, or a specified portion thereof, is recommended to be declared substantially complete. The Owner shall notify the Contractor, in writing, of the date the Owner accepts the Work, or the specified portion thereof, as substantially complete or the Owner shall notify the Contractor of the deficiencies to be corrected or completed before such Work will be accepted as substantially complete.

- (b) The Contractor shall notify the Owner, in writing on the Certificate of Completion by the Contractor (Form AC-13.2), of the date when the Work has reached or will reach Final Completion and will be ready for final inspection and testing. The notice shall be given at least five (5) days in advance of said date and shall be forwarded through the Architect/Engineer, who will attach his endorsement as to whether or not he concurs in the Contractor’s statement that the Work will be ready for inspection and testing on the date given. That inspection and any necessary testing shall be conducted in the same manner as the inspection for Substantial Completion. When the Work is finally and totally complete, including the elimination of all defects, and the Owner has received all project close-out deliverables, the Work shall be finally accepted by the Owner and final payment shall be made in accordance with Section 36 of these General Conditions.
- (c) The Architect/Engineer shall conduct the inspections. The Owner may elect to have other persons of its choosing also participate in the inspections. If one or more Substantial or Final Completion reinspections are required, the Contractor shall reimburse the Owner for all costs of reinspection or, at the Owner’s option, the costs may be deducted from payments due to the Contractor.
- (d) A representative of the local Building Official will either be present at the Substantial and Final Completion inspections or otherwise inspect the completed Work and advise the Owner whether the Work meets the requirements of the applicable building code(s).
- (e) Approval of Work at or as a result of any inspection required herein shall not release the Contractor or his surety from responsibility for complying with the Contract.

#### **44. GUARANTEE OF WORK**

- (a) Except as otherwise specified, all Work shall be, and is hereby, guaranteed by the Contractor against defects resulting from the use of materials, equipment or workmanship, which are defective, inferior, or not in accordance with the terms of the Contract, for one (1) year from the date of Final Completion of the entire Project by the Owner. Equipment and facilities which have seasonal limitations on their operation (e.g. heating or air conditioning units) shall be guaranteed for one (1) full year from the

date of seasonally appropriate tests and acceptance, in writing, by the Owner. Where the Owner agrees to take Beneficial Occupancy of a portion or phase of the Work which has been determined to be substantially complete before the entire Work is finally completed, the guarantees for the materials, equipment and workmanship in that portion or phase shall begin on the date that the Owner takes Beneficial Occupancy, unless otherwise specified in the Supplemental General Conditions, Special Conditions, or by separate agreement.

- (b) Unless the Owner approves otherwise, the warranty period for new equipment shall begin with the contract substantial completion date, regardless of whether the Contractor has used said equipment in the performance, installation, or application of the Work.
- (c) If, within any guarantee period, Work which is not in accordance with the Contract, Defective Work, or inferior material, equipment or workmanship is noted by the Owner or Architect/Engineer which requires or renders necessary repairs or changes in connection with the guaranteed Work, the Contractor shall, promptly upon receipt of notice from the Owner, such notice being given not later than two weeks after the guarantee period expires, and without expense to the Owner:
  - (1) Place in satisfactory condition in every particular all of such guaranteed Work and correct all defects, inferior materials, equipment or workmanship therein;
  - (2) Make good all damage to the structure or Site or equipment or contents thereof, which, in the opinion of the Owner or the Architect/Engineer, is the result of the use of materials, equipment or workmanship which are inferior, defective or not in accordance with the terms of the Contract; and
  - (3) Make good any Work or materials or the equipment and contents of structures and/or Site disturbance that results from fulfilling the provisions of this Section.
- (d) In any case, when in fulfilling the requirements of the Contract and this guarantee or any other guaranty or warranty, the Contractor disturbs any work performed by a separate contractor, he shall restore such work to a condition satisfactory to the Architect/Engineer and Owner and guarantee such restored work to the same extent as if it was guaranteed under this Contract.
- (e) If the Contractor, after notice, fails to proceed promptly to comply with the terms of the guarantee as set forth in this Section, the Owner may have the defects or inferior materials, equipment or workmanship corrected and the Contractor and his surety shall be liable for all expense incurred.
- (f) All special warranties and guarantees applicable to definite parts of the Work that may be stipulated in or required by the Contract Documents shall be subject to the terms of this Section during the first year of the life of such special warranty or guarantee.
- (g) The guarantee of this Section shall be in addition to and not in lieu of all other warranties, express or implied, applicable to or arising from this Contract or by law.
- (h) Nothing contained in this Section shall be construed to establish a period of limitation with respect to any other obligation which the Contractor might have under the Contract Documents, including liability for Detective Work under Section 30. This Section relates only to the specific obligation of the Contractor as set forth in this Section to correct the Work and does not limit the time within which

his obligation to comply with the Contract Documents may be sought to be enforced, nor the time within which proceedings may be commenced to establish the Contractor's liability with respect to his other obligations under the Contract Documents.

- (i) In the event the Work of the Contractor is to be modified by another contractor, either before or after the Final Inspection provided by Section 43 of the General Conditions, the first Contractor shall remain responsible in all respects under this Section's Guarantee of Work and under any other warranties or guarantees, express or implied, applicable to or arising from this Contract or by law. However, the Contractor shall not be responsible for any defects in material or workmanship introduced by the contractor modifying his Work. The first Contractor and the contractor making the modifications shall each be solely responsible for his respective work. The contractor modifying the earlier Work shall be responsible for any damage to or defect introduced into the Work by his modification. If the first contractor claims that a subsequent contractor has introduced defects of materials and/or workmanship into his Work, it shall be the burden of the contractor making the claim to demonstrate clearly the nature and extent of such introduced defects and the other contractor's responsibility for those defects. Any contractor modifying the work of another shall have the same burden if he asserts that defects in his work were caused by the contractor whose work he is modifying.

**45. ASSIGNMENTS OF CONTRACTUAL OBLIGATIONS**

Neither party to the Contract shall assign the Contract in whole or any part without the written consent of the other, nor shall the Contractor assign any monies due or to become due to him hereunder, without the prior written consent of the Owner. No assignment shall relieve any party from its obligations under the Contract.

**46. CONTRACTUAL DISPUTES (§2.2-4363, Code of Virginia)**

Contractual claims, whether for money or for other relief, shall be submitted, in writing, no later than sixty (60) days after final payment; however, written notice of the Contractor’s intention to file such claim must be given at the time of the occurrence or beginning of the Work upon which the claim is based. The filing of a timely notice is a prerequisite to recovery under this Section. Although the Contractor may be required to submit certain classes of claims prior to final payment, and the Contractor is not prevented from filing claims during the pendency of the Work, the Owner shall not be obligated to render a final written decision on any claim until after final payment. All claims shall be submitted along with all practically available supporting evidence and documentation.

No written decision denying a claim or addressing issues related to the claim, if rendered prior to final payment, shall be considered a denial pursuant to this Section unless the written decision makes express reference to this Section and is signed by the Owner or his designee. The Contractor may not institute legal action prior to receipt of the Owner’s final written decision on the claim unless the Owner fails to render such a decision within ninety (90) days of submission of the claim or within ninety (90) days of final payment, whichever is later.

The decision of the Owner shall be final and conclusive unless the Contractor within six (6) months of the date of the final decision on a claim, initiates legal action as provided in §2.2-4364 of the Code of Virginia. Failure of the Owner to render a decision within 90 days shall not result in the Contractor being awarded the relief claimed nor shall it result in any other relief or penalty. The sole result of the Owner’s failure to render a decision within 90 days shall be the Contractor’s right to immediately institute legal action. No administrative appeals procedure pursuant to §2.2-4365 of the Code of Virginia has been established for contractual claims under this Contract. Venue for any litigation arising hereunder shall be in the Circuit Court for the County of Albemarle, Virginia.

**47. ASBESTOS**

- (a) This subsection applies to projects involving existing buildings where asbestos abatement is not a part of the Work, when the scope of the project has been reviewed and a comprehensive survey conducted by an individual licensed by the Virginia Department of Professional and Occupational Regulation to conduct building inspections for asbestos containing materials in buildings, and where the Owner has attempted to remove or encapsulate all asbestos containing material that may become friable or damaged during this Project.

Prior to commencement of Work, the results of the comprehensive survey or any other asbestos survey shall be made available to the Contractor, who shall be responsible for performing his Work

so as not to disturb any remaining asbestos, encapsulated or otherwise, identified in such survey or surveys.

If the Contractor discovers or inadvertently disturbs any material that he knows, should have known or has reason to believe, may contain asbestos that has not been previously identified, was overlooked during the removal, was deemed not to be friable or was encapsulated, the Contractor shall stop Work in the area containing or suspected to contain the asbestos, secure the area, and notify the Owner and the Architect/Engineer immediately by telephone or in person with written notice as soon as possible. The Owner will have the suspect material sampled.

If the sample is positive and must be disturbed in the course of the Work, the Owner shall have the material repaired or removed and shall pay for the bulk sample analysis.

Except as provided in §11-4.1 of the Code of Virginia, if the material disturbed is not within the Contractor's authorized Work and/or Work area or under this Contract, the Contractor shall pay for all associated sampling and abatement Costs.

- (b) If asbestos abatement is included as a part of the Work, the Contractor shall assure that the asbestos abatement work is accomplished by those duly licensed as described in Section 3 of these General Conditions and in accordance with the specific requirements of the Contract and all applicable laws and regulations.
- (c) If asbestos abatement is included as part of the Work, the licensed asbestos Subcontractor shall obtain the insurance required under Section 11(e) of these General Conditions.

#### **48. TRAINING, OPERATION AND MAINTENANCE OF EQUIPMENT**

- (a) As a part of the Work, the Contractor in conjunction with his Subcontractors and Suppliers shall provide the Owner's operations and maintenance personnel with adequate instruction and training in the proper operation and maintenance of any equipment, systems, and related controls provided or altered in the Work. The training requirements may be further defined in the specifications.
- (b) The Contractor shall provide the Owner with a minimum of two (2) copies of operating, maintenance and parts manuals for all equipment and systems provided in the Work. Further specific requirements may be indicated in the specifications.

#### **49. PROJECT MEETINGS**

- (a) The intention of this Section is that the Contractor, the Owner and the A/E have timely exchange of information and cooperate to accomplish the Work as required by the Contract Documents. The Contractor is responsible for managing the Work, obtaining approvals and requesting clarifications on a timely, reasonable basis. The Owner and its A/E are responsible for making a reasonable effort to provide timely responses to the Contractor.

(b) **Preconstruction Meeting:**

Prior to the start of construction and no later than 15 calendar days after the Notice to Proceed, a “Preconstruction” meeting shall be held with attendees to include the Owner’s Project Manager and Project Inspector, the Architect/Engineer’s project manager and representatives of each design discipline involved in the Project, the Contractor’s project manager and superintendent (and scheduler, if Contractor desires), and representatives of the Contractor’s major Subcontractors. The purpose of the meeting is to clarify and discuss the specifics related to, but not limited to, the following:

- (1) Persons involved from each entity and their chain of authority including the names of persons authorized to sign Change Orders and any limits to their authority.
- (2) Names, addresses, telephone numbers, FAX numbers, and email addresses to be used for Requests for Information (RFI), Requests for Clarification (RFC), Requests for Proposals (RFP), shop drawings, submittals, and notices.
- (3) Contractor’s proposed construction schedule and Owner’s sequencing requirements, if any.
- (4) Schedule of Values and Certificate for Payment (Form AC-12) requirements and procedures.
- (5) Procedures for shop drawings, product data and Submittals.
- (6) Procedures for handling Field Orders and Change Order Form AC-11.
- (7) Procedures for Contractor’s request for time extension, if any.
- (8) Construction Site requirements, procedures and clarifications to include:
  - Manner of conducting the Work presentation to be done by members of the project team, preferably Contractor’s superintendent and project manager.
  - Site specialties such as dust and erosion control, stormwater management, project signs, clean up and housekeeping, temporary facilities, utilities, security, and traffic.
  - Safety.
  - Layout of the Work.
  - Quality control, testing, inspections and notices required.
  - Site visits by the A/E and others.
  - Owner’s Project Inspector duties.
  - Running Punch List.
  - As-Built Drawings.
- (9) Procedures and documentation of differing or unforeseen Site conditions.
- (10) Monthly Pay Meeting.
- (11) Project Close-Out requirements and procedures.
- (12) Project records.

(c) **Monthly Pay Meeting:**

Section 36 establishes the requirement for a monthly pay meeting which will usually be held at or near the Site. In addition to Owner, A/E and Contractor representatives, the following representatives, at a minimum, should be available to attend portions of the meeting, as applicable or necessary:

- Owner's Project Inspector.
- Contractor's project superintendent.
- A/E representative of each discipline where Work was performed for the current pay request or where Work is projected to be performed in the coming month.
- A representative of each subcontractor who performed work included in the current pay request.
- A representative of each subcontractor who is projected to perform work in the coming month.

The following topics should be included, as a minimum, in the monthly pay meeting:

- (1) Observations of status, quality and workmanship of Work in progress.
  - (2) Validation of the Schedule of Values and Certificate for payment.
  - (3) Conformance with proposed construction schedule.
  - (4) Outstanding Requests for Information, Requests for Clarification and Requests for Proposal.
  - (5) Submittals with action pending.
  - (6) Status of pending Change Orders.
  - (7) Status of Running Punch List items.
  - (8) Work proposed for coming pay period.
  - (9) Discussions of any problems or potential problems which need attention.
- (d) **Other Meetings:**  
Requirements for other meetings, such as progress meetings, coordination meetings, preinstallation meetings and/or partnering meetings, may be included in the Contract Documents.

\*\*\*\*\* END OF GENERAL CONDITIONS \*\*\*\*\*

## SUPPLEMENTAL GENERAL CONDITIONS

The COUNTY OF ALBEMARLE CONSTRUCTION CONTRACT GENERAL CONDITIONS (Revised May 2018) are modified and supplemented as hereinafter described.

1. Section 11(B) Contractor's and Subcontractor's Insurance: Insurance Requirements
  - (a) Worker's Compensation: requires a minimum of **\$1,000,000**.
  - (b) General Liability: requires a minimum of **\$1,000,000**.
  - (c) Automobile Liability: requires a minimum of **\$1,000,000**.
  - (d) Umbrella Liability: requires a minimum of **\$1,000,000**.
  - (e) Environmental Pollution is not required by this solicitation
  - (f) Professional Liability is not required by this solicitation.
  - (g) Cyber Liability is not required by this solicitation
  
2. Section 12 – BUILDER'S RISK INSURANCE
  - (a) The requirements of this section of the General Conditions for builders risk insurance on the full value of the entire building are waived for this project. The Owner maintains insurance on the existing building (including fire, vandalism and extended coverage). **However, the Contractor shall provide builders risk insurance for the Work in an amount equal to one hundred percent (100%) of the Contract Price for the Work.** The loss, if any, is to be made adjustable with and payable to the Owner, in accordance with its interests, as they may appear. The Owner, its officers, employees and its agents, shall be named as loss payee in any policy of insurance issued. Written evidence of the insurance shall be filed with the Owner prior to execution of the Contract. In the event of cancellation of this insurance, not less than thirty (30) days prior written notice must be sent to the Owner. A copy of the policy of insurance shall be given to the Owner upon demand.
  
  - (b) Not used
  
  - (c) The Contractor is responsible for providing any desired coverage for Contractor's or Subcontractors' buildings, equipment, materials, tools or supplies that are on-site.
  
3. Section 42 - DAMAGES FOR DELAY, EXTENSION OF TIME  
Add the following paragraphs:
  - (j) It is imperative that the Work in this contract be substantially completed not later than **August 9, 2024** to give time for the Owner to furnish and equip the facility and meet other contractual obligations. The Contractor represents and agrees that he has taken into account in his bid the requirements of the bid documents, the location, the time allowed for the Work, local conditions, availability of materials, equipment, and labor, and any other factors which may affect performance of the Work. The Contractor agrees and warrants that he will achieve substantial completion of the Work not later than **August 9, 2024**.

- (1) Assuming timely execution of the Contract with applicable Bonds, Notice to Proceed will be given to the Contractor on or before **July 5, 2024** with construction to begin no earlier than **July 8 2024**.
- (k) Subject to the provisions of the General Conditions allowing for extension of time allowed for completion of the Work, if the work is not substantially completed by the specified date, the Contractor shall owe to the Owner, not as a penalty but as liquidated damages, the sum of **One Thousand Dollars (\$1,000.00)** per day for each and every calendar day for delay in substantial completion of the Work beyond **August 9, 2024**. Likewise, if the Work is not finally completed by the specified date, the Contractor shall owe to the Owner, not as a penalty but as liquidated damages, the sum of **Five Hundred Dollars (\$500.00)** per day for each and every calendar day of delay in final completion of the Work.
- (l) The Owner may withhold from the monthly Progress Payment, the current value of the liquidated damages. Failure of the Owner to withhold liquidated damages during ongoing operations that have exceeded the Contract Completion Date is not a waiver of the Owner's entitlement to damages as set forth in the Contract Documents.
- (m) Final accounting of liquidated damages will be administered through a deduction in the final amount owed the Contractor.

**SPECIAL CONDITIONS  
ALBEMARLE COUNTY PUBLIC SCHOOLS**

1. Worker Standards of Conduct/Dress – Hard hats, safety shoes, appropriate shirts and pants are required at all times. Smoking is prohibited on school property. There is to be no contact or harassment of any kind between workers, teachers and students. Only the project superintendent may contact the school staff if necessary. Violence, Swearing, Drugs, Alcohol, Firearms and Weapons are prohibited on school property. Any workers violating these standards of conduct shall be ordered off the site and not allowed to return.
2. Workers shall wear identification indicating the company that employs them while working in an occupied school, even during summer months.
3. Drawings and/or Specifications – Any Additional Instructions by Architect/Owner to explain drawing and specifications shall be binding on Contractor.
4. The Contractor (or his designated sub-contractor) shall obtain and pay the fees for all permits necessary for the construction of the project, unless specifically stated otherwise. The Owner will pay for the County Building Permit fees, and the Contractor shall obtain the permits. The Owner will pay for water and sewer connection fees, and the contractor shall obtain the permit. The Contractor shall pay for the tapping fee whether done by himself or pay the Service Authority to make tap. Fees for all bonds (excluding erosion control bonds) will be the sole responsibility of the Contractor. It is the responsibility of the Contractor to determine which permits are necessary. The Owner will pay for the permanent connection to franchised utility companies, electric service, and gas service. The Contractor shall coordinate and schedule all permanent utility service work.
5. Regarding asbestos work, the general contractor shall be responsible for submitting any required notices to all appropriate regulatory agencies, and shall do so within the required timeframe.
6. Contractor’s staging area, protective barriers and safety fencing, employee parking, loading access and stockpiling of soils (*where applicable*) shall be as shown on the plans or as approved by Owner.
7. Contractor’s staging area and general construction site shall be kept neat and clean so that grass is cut and debris and trash is removed on a weekly basis if not more frequently.
8. Safe access to the designated areas adjacent to the construction area must be maintained at all times for pedestrians and maintenance vehicles.
9. Liquidated Damages: Shall be in accordance with the Supplementary General Conditions.
10. Section 01200 Project Meetings and Section 01300 Submittals are to include the following:
  - 1) Bi-Monthly Job-Site meetings
  - 2) The Contractor’s project superintendent shall provide the Architect and Owner with copies of his daily report on a weekly basis including manpower per trade, job progress, weather and activities.

11. Application for Payment and payments shall be delayed when project is not in compliance with Erosion Control Plan, permits, or any related instructions given by Owner. Lack of Project Cleanliness may also delay payment. Weekly broom cleaning required for interior renovations.
12. The Contractor shall coordinate all construction operations and deliveries with the school activity schedule. If school is in session while construction is underway, deliveries to the construction site shall not be allowed between the hours **7:30 a.m. and 8:30 am** and **1:30 p.m. and 2:30 p.m.**
13. If school is in session while construction is underway, the Contractor shall allow for 5 days when work will be prohibited for student special testing in the school in the spring. These dates will be confirmed at the Pre-Construction meeting.
14. Contractors Work within the Existing and Functioning School Area shall be limited to when school is not in session (i.e. during summertime and/or after hours). Excessively noisy work or work producing noxious fumes adjacent to classrooms in session may also be subject to work after regular hours.
15. Hours of work will be limited for projects with exterior work areas, noisy loading or unloading, and work with close neighbors who could be adversely effected.
16. At the completion of the project and before the Final Application for Payment will be approved, Contractor shall provide the Owner written statement certifying that the work is asbestos free.
17. UL Labels are required on all electrical and mechanical equipment. If unlabeled equipment is delivered to the job site, Contractors shall remove and replace with properly labeled equipment or shall pay for UL field testing to properly label prior to payment being made such equipment.
18. Testing/Special Inspections - Owner shall obtain and pay for testing and special inspections services. The Contractor shall pay for any required re-testing due to failed initial tests. Special Inspectors instructions shall be binding on the Contractor. Contractor shall call the testing company designated by the Owner and coordinate any special inspections. Contractor shall provide the Special Inspector with any necessary equipment, such as ladders, scaffolding, etc. for inspection purposes. At the completion of the project and before the Final Application for Payment will be approved, all deficiencies on any special inspection reports, shall be remedied.
19. Building Inspections Department – The Contractor shall call for inspections (*in accordance with the local department's procedures or by no later than 4 p.m. the day prior the inspection is requested*). Requests for fire alarm inspections require several days advance notice. Fire alarm inspection requests shall be made and coordinated by the Contractor with assistance of all related trades such as fire alarm, mechanical and automatic control system subcontractors. A successful dry run test must be made and witnessed by the Owner's representative before calling a County Inspection.
20. Retainage shall be 5%, and will not be reduced until the HVAC Testing and Balancing report is approved by Architect and Owner. (*Note this may require a delay to provide appropriate outside air temperatures for both heating and cooling tests.*) All Owner training, Owner manuals, spare parts and warranties are also to be received and approved by Architect and Owner and before retainage is released.
21. Building security is the responsibility of the Contractor until final acceptance.

22. The Contractor shall provide approved, framed, operating and maintenance instruction, wiring diagrams and control diagrams as applicable:

Sprinkler System	Fire Alarm System	Telecommunication System
Heating	Ventilating System	Sound System
Fans	Pumps	Motors
Generator	Energy Management	Other Alarms

Any other items or systems required but not specifically listed.

23. Constructor to provide comprehensive training and equipment demonstration for the Owner’s designated representatives and the Contractor shall schedule at least 2 weeks in advance for Owner’s coordination review and approval.

24. Fire Protection System (Fire Sprinkler) shop drawings and hydraulic calculations shall be prepared, certified and stamped by a professional engineer, licensed in the state of Virginia, at the Contractor’s expense.

25. Cleaning during construction: Areas of work shall be cleaned broom clean at least weekly to minimize tracking dirt; Owners existing equipment and facility shall be protected from dust, splash or splatter and cleaned or replaced to return to pre-construction conditions.

26. Final Cleaning to be performed to the Owner’s satisfaction. If unsatisfactory cleaning is not remedied within 24 hour written notice to Contractor from Owner, Owner shall complete and deduct from Contractor’s final payment.

27. Weather Days: shall be counted cumulatively for the project duration and agreed upon monthly in the pay meeting notes, never to shorten the duration.

28. Temporary Facilities  
Power and Water is provided at the site, by Owner, so long as privilege is not abused.  
Contractor is to provide Temporary Toilet facility, do not use the restrooms.

29. Hazardous Materials: PCB or ACM materials may be found in window caulk, floor tiles, mastic behind display boards, mastic at piping insulation, science counter tops, and or window and canopy transit panels. Contractor to notify Owner if suspicious material is found on site, for Owner to coordinate removal (verify if Owner or contractor abates may vary by project.).

30. Contractor will complete and submit documentation necessary for input into Owner’s facilities and maintenance asset management system, FMX. Owner will provide a template document for contractor to submit the required information on prior to closing out the project. Necessary documentation to be completed on Owner’s form includes key information such as manufacturer, model numbers, serial numbers, expected life, and other key components for all major equipment that is installed. Other documentation may include paint colors, flooring manufacturers, and room specific interior upgrades for all new construction and renovation projects.

\*\*\* END OF SPECIAL CONDITIONS \*\*\*

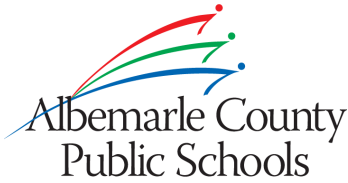

**CONTRACT #«number»**  
**«Company»**  
**«Address 1»**  
**«Address 2»**  
**«City», «State» «Postal Code»**  
**«corporate status, as confirmed by SCC»**  
**(Contractor)**

Project name:	_____
A/E, if applicable:	_____
A/E contract #:	_____
Project Mgr:	_____

**SCHOOL BOARD OF ALBEMARLE COUNTY, VIRGINIA,**  
 401 McIntire Rd.  
 Charlottesville, Virginia 22902  
**a body corporate under the laws of the Commonwealth of Virginia,**  
**(School Board or Owner)**

This Agreement (“Agreement” or “Contract”) made and entered into on this \_\_\_\_ day of \_\_\_\_\_, 20XX, between the Contractor as identified above and the School Board (collectively, the Parties), hereby agree, in consideration of the mutual covenants and stipulations set forth below:

- Scope of Work:** The Contractor shall furnish all labor, equipment, and materials and perform all work for the project as described in the Invitation to Bid (IFB) # \_\_\_\_\_, p. \_\_\_\_\_ and the Owner’s plans and specifications, including all work described in the Bid Form as Base Bid plus additives, (collectively, the Work) in strict accordance with the Contract Documents. In brief, the Contractor shall \_\_\_\_\_.
- Incorporation of documents and Order of Precedence:** To the extent that they do not conflict with the terms of this Agreement, the following documents are incorporated by reference in their entirety:
  - the Invitation to Bid, # \_\_\_\_\_;
  - the Bid Form submitted by the Contractor; (with Post Bid Modification if applicable)
  - the County of Albemarle Construction Contract General Conditions, as included in the IFB;
  - the Supplemental General Conditions, if any;
  - the Special Conditions attached to the Owner’s Invitation for Bids;
  - the Owner’s Project Plans and Specifications dated \_\_\_\_\_; and modifications shown as Addenda \_\_\_\_\_; and
  - the Project Manual dated \_\_\_\_\_ (which may include some or all of the above documents).

In the event that a conflict or ambiguity exists or is created between this Agreement, the IFB, and/or the Contractor’s submitted Bid Form, the terms of this Agreement first and the IFB second, if necessary, shall govern and supersede any such conflicting or ambiguous terms. The Supplemental General Conditions shall thereafter take precedence over the General Conditions.

- Payment/Consideration Schedule:** In consideration of the Work to be performed by Contractor, as set forth in the section entitled, “Scope of Work,” the School Board agrees to pay Contractor for completed and accepted work the total sum of \_\_\_\_\_ dollars (\$ \_\_\_\_\_) as calculated below:

Base bid:	\$ _____	
Additive 1:	\$ _____	for _____
Additive 2:	\$ _____	for _____
<b>Total:</b>	<b>\$ _____</b>	

4. Term: The Work shall be commenced on a date to be specified in a written order of the Owner and shall be Substantially Completed within [REDACTED] calendar days. The Work shall be finally completed within [REDACTED] days after the date of Substantial Completion of the Work or no later than the date of Final Completion of [REDACTED], whichever is sooner. Time is of the essence.
5. Non-Appropriation: The continuation of the terms, conditions, and provisions of this Agreement beyond June 30 (the end of the School Board's fiscal year) of any year, is subject to its approval and ratification by the School Board and appropriation by them of the necessary money to fund said contract for each succeeding year. If sufficient funds are not appropriated and budgeted in any fiscal year for payments due under this Agreement, the School Board shall immediately notify Contractor, and this Agreement shall terminate on the last day of the fiscal year for which appropriations were received without penalty or expense to the School Board of any kind whatsoever.
6. Preconditions to Obligation: The School Board shall not be obligated to purchase or pay for goods, services, or materials under this Agreement unless the School Board has ordered such goods, services, and/or materials and until the Contractor has delivered any ordered goods, services, and/or materials. The School Board may increase or decrease quantities of ordered goods, services, and materials as required and in its discretion.
7. Faith-based Organizations: The School Board does not discriminate against faith-based organizations in accordance with Code of Virginia §2.2-4343.1.
8. Nondiscrimination: Pursuant to Virginia Code §§ 2.2-4201 and 2.2-4311, during the performance of this Contract, Contractor agrees as follows:
  - A. Contractor will not discriminate against any employee or applicant for employment because of race, religion, color, sex, national origin, age, disability, or any other basis prohibited by state law relating to discrimination in employment, except where there is a bona fide occupational qualification reasonably necessary to the normal operation of Contractor. Contractor agrees to post in conspicuous places, available to employees and applicants for employment, notices setting forth the provisions of this Nondiscrimination clause, including the names of all contracting agencies with which the Contractor has contracts over \$10,000;
  - B. Contractor will, in all solicitations or advertisements for employees placed by or on behalf of Contractor, state that Contractor is an equal opportunity employer;
  - C. Notices, advertisements and solicitations placed in accordance with federal law, rule or regulation shall be deemed sufficient for the purpose of meeting the requirements of this section; and
  - D. Contractor shall include the provisions of the foregoing paragraphs A, B, and C in every subcontract or purchase order of over \$10,000, so that the provisions will be binding upon each subcontractor or vendor.
9. Drug-Free Workplace: Pursuant to Virginia Code Section § 2.2-4312, during the performance of this Contract, Contractor agrees to:
  - A. Provide a drug-free workplace for Contractor's employees.
  - B. Post in conspicuous places, available to employees and applicants for employment, a statement notifying employees that the unlawful manufacture, sale, distribution, dispensation, possession, or use of a controlled substance or marijuana is prohibited in Contractor's workplace and specifying the actions that will be taken against employees for violations of such prohibition.
  - C. State in all solicitations or advertisements for employees placed by or on behalf of Contractor that Contractor maintains a drug-free workplace.
  - D. Include the provisions of the foregoing clauses in every subcontract or purchase order over \$10,000, so that the provisions will be binding upon each subcontractor or vendor.

10. Compliance with Immigration Laws: Contractor does not and shall not during the performance of this Agreement knowingly employ an unauthorized alien as defined in the federal Immigration Reform and Control Act of 1986, pursuant to Virginia Code §2.2-4311.1.
11. Compliance with All Laws: Contractor shall comply with all federal, state, and local statutes, ordinances, and regulations now in effect or hereafter adopted, in the performance of scope of work set forth herein. Contractor represents that it possesses all necessary licenses and permits required to conduct its business and will acquire any additional licenses and permits necessary for performance of this Agreement prior to the initiation of work.
12. Business Entity Registration. Pursuant to Virginia Code § 2.2-4311.2, Contractor shall be registered and authorized to transact business in the Commonwealth as a domestic or foreign business entity if so required by Title 13.1 or Title 50 or as otherwise required by law. Contractor shall submit proof of a required registration to the School Board. Additionally, if required, Contractor shall not allow its existence to lapse or its certificate of authority or registration to transact business in the Commonwealth, if so required under Title 13.1 or Title 50 of the Code of Virginia, to be revoked or canceled at any time during the term of the Agreement.
13. Business License Requirement: If Contractor is a business located in Albemarle County, Virginia or at any time during the performance of this Agreement obtains situs for purposes of business license taxes, it shall be unlawful for such business to conduct or engage in such business, trade, or occupation without having first obtained the proper license from the Albemarle County Department of Finance. Contractor covenants that it has a business license where one is required to perform this Agreement.
14. Non-Assignment: All of the conditions and provisions in this Agreement shall extend to and bind the legal representatives, successors and assigns of the respective parties. Neither party to the Agreement shall assign or transfer their interest in the contract without the prior written consent of the other, which shall not be unreasonably withheld.
15. Audit: The Contractor shall maintain full and accurate records with respect to all matters covered under the Agreement including, without limitation, accounting records, written policies and procedures, time records, telephone records, reproduction cost records, travel and living expense records and any other supporting evidence necessary to substantiate charges related to the Agreement. Contractor's records shall be open to inspection and subject to audit and/or reproduction, during normal working hours by the School Board and its employees, agents or authorized representatives to the extent necessary to adequately permit evaluation and verification of any invoices, payments, or claims submitted by Contractor pursuant to this Agreement. Such records subject to examination shall also include, without limitation, those allocations as they may apply to costs associated with the contract. The School Board's employees, agents, or authorized representatives shall have access to the Contractor's facilities, shall have access to all necessary records, and shall be provided adequate and appropriate workspace, in order to conduct audits in compliance with this paragraph.
16. Termination with Cause: In the event that Contractor shall for any reason or through any cause be in default of the terms of this Agreement, the School Board may give Contractor written notice of such default by certified mail/return receipt requested at the address set forth in Section 20 herein. Unless otherwise provided, Contractor shall have ten (10) days from the date such notice is mailed in which to cure the default. Upon failure of Contractor to cure the default, the School Board may immediately cancel and terminate this Agreement as of the mailing date of the default notice. Upon termination, Contractor shall withdraw its personnel and equipment, cease performance of any further work under the Agreement, and turn over to the School Board any work in process for which payment has been made. In the event of violations of law, safety or health standards and regulations, this Agreement may be immediately cancelled and terminated by the School Board, and provisions herein with respect to opportunity to cure default shall not be applicable.

17. Termination without Cause: The School Board may at any time, and for any reason, terminate this Agreement by written notice to Contractor specifying the termination date, which shall be not less than thirty (30) days from the date such notice is mailed. In the event of such termination, Contractor shall be paid such amount as shall compensate Contractor for the work satisfactorily completed, and accepted by the School Board, at the time of termination. If the School Board terminates this Agreement without cause, Contractor shall withdraw its personnel and equipment, cease performance of any further work under this Agreement, and turn over to the School Board any work completed or in process for which payment has been made.
18. Choice of Laws and Venue: This Agreement shall be governed by the provisions hereof and by the laws of the Commonwealth of Virginia, excepting the law governing conflicts of laws. Disputes arising out of this Agreement shall be resolved in the courts of the Commonwealth of Virginia in and for Albemarle County.
19. Indemnification and Hold Harmless: Contractor hereby assumes the entire responsibility and liability for any and all damages to persons or property caused by or resulting from or arising out of any act or omission on the part of Contractor, its subcontractors, agents, or employees under or in connection with this Agreement or the performance or failure to perform any work required by this Agreement. Contractor shall indemnify and hold harmless the School Board and its agents, volunteers, servants, employees, and officials from and against any and all claims, losses, or expenses, including reasonable attorney's fees and litigation expenses suffered by any indemnified party or entity as the result of claims or suits due to, arising out of or in connection with (a) any and all such damages, real or alleged, (b) the violation of any law applicable to this Agreement, and (c) the performance of the work by Contractor or those for whom Contractor is legally liable. Upon written demand by the School Board, Contractor shall assume and defend at Contractor's sole expense any and all such suits or defense of claims made against the School Board, its agents, volunteers, servants, employees, or officials.
20. Notices: All notices and requests required or permitted hereunder shall be sent by United States certified mail, return receipt requested, and to be effective, shall be postmarked not later than the final date for giving of such notice, or such notices may be sent by commercial messenger service, in which event, to be effective, such notices shall be delivered to a commercial messenger service not later than the final date for giving such notice. Alternatively, notice can be sent electronically to the parties and email addresses listed below.

Notices for the School Board shall be addressed as follows:



Charlottesville, VA 22902

With a copy to:

Allison McNally  
Chief Procurement Officer  
401 McIntire Rd., Room 248  
Charlottesville, VA 22902  
[amcnally@albemarle.org](mailto:amcnally@albemarle.org)

Notices for Contractor shall be addressed as follows:



Such addresses may be changed at any time and from time to time by like written notice given by either party to the other.

21. Entire Agreement: This Agreement and the documents incorporated by reference and included expressly as Exhibits to this Agreement constitute the entire agreement between the Parties. This Agreement supersedes all prior written or oral agreements or proposals between the parties, regarding the subject matter of this Agreement. This Agreement may not be modified except in a writing signed by both parties that is expressly stated to be an amendment hereto.
22. Independent Contractor: Contractor shall be at all times an independent contractor and, as such, shall have and maintain complete control over all of its employees and operations. Neither Contractor nor anyone employed by it shall be, represent, act, purport to act, or be deemed to be an agent, representative, employee or servant of the School Board. Nothing in this section shall be deemed to absolve or otherwise limit the Contractor's liability and responsibility to safely and correctly perform its duties under this Agreement.
23. Waiver: No failure of the School Board to exercise any right or power given to it by law or by this Agreement or to insist upon strict compliance by Contractor with any of the provisions of this Agreement, and no custom or practice of the parties at variance with the terms hereof, shall constitute a waiver of the School Board's right to demand strict compliance with the terms of this Agreement.
24. Interpretation: Whenever the context hereof shall require, the singular shall include the plural, the plural the singular, and the use of any gender shall be applicable to all genders.
25. Severability: The provisions of this Agreement shall be deemed to be severable, and should any one or more of such provisions be declared or adjudged to be invalid or unenforceable, the remaining provisions shall be unaffected thereby and shall remain in full force and effect.
26. Contract Claims by Contractor: Prompt knowledge by the School Board of an existing or impending claim for damages or other relief may alter the plans, scheduling, or other action of the School Board and/or result in mitigation or elimination of the effects of the claim. Therefore, a written statement providing the School Board with notice of the Contractor's intention to file a claim which (i) describes the act or omission by the School Board or its agents that the Contractor contends caused it damages or entitles it to other relief; and (ii) provides a description of the nature and amount of the claim. Such written statement shall be submitted to the Purchasing Office of the Albemarle County Department of Finance within 20 days of the time of the occurrence or beginning of the work upon which the claim is based; provided, however, if such damage is deemed certain in the opinion of the Contractor to result from its acting on an order from the School Board, it shall immediately take written exception to the order. For purposes of this provision, "claim" shall include, without limitation, any request for an increase in the Agreement price or time and any request for equitable adjustment. Submission of a notice of claim as specified shall be mandatory, and failure to submit such notice shall be a conclusive waiver to such claim for damages or other relief by the Contractor. Neither an oral notice or statement, nor an untimely notice or statement will be sufficient to satisfy the requirements herein. The School Board will review the claim and render a final decision in writing within thirty (30) days of receipt of Contractor's written request for a final decision. Such decision shall be final and binding to the fullest extent allowed by law.
27. Claims for Extra Compensation: If Contractor encounters work and services not included in this Agreement or any supplement thereto but which in the opinion of Contractor is necessary for the successful completion of the Agreement and requires extra compensation, Contractor shall, before it begins the work on which it bases its claim, promptly notify the Purchasing Office of the Albemarle County Department of Finance in writing of its intention to perform the work and to make claim for extra compensation. Notification by Contractor under the terms of this paragraph shall not be construed as proving the validity of the claim. No claim for extra compensation will be filed or considered unless notification is given as herein set forth. Upon notification, the School Board shall promptly review any claim for extra compensation. If a claim is accepted by the School Board, it shall be paid as extra work under the terms of a supplemental agreement executed by the parties *before such work is begun*. The amounts claimed as extra compensation by Contractor shall be separately itemized, become a part of the claim, and serve as documentation thereto. The amounts

itemized shall be in sufficient detail to enable the School Board to analyze the need for the extra work and the costs claimed for the work.

28. Payments to Subcontractors:

- a. This is a construction contract under the VPPA. Therefore, Contractor shall pay all subcontractors in the manner provided in Virginia Code Section 2.2-4354(1).
- b. Contractor shall pay all subcontractors in the manner provided in Virginia Code Section 2.2-4354(2-5).

29. Insurance: Contractor shall purchase and maintain, at its sole expense, and from a company or companies authorized to do business within the Commonwealth of Virginia, insurance policies protecting from claims which may arise out of or result from Contractor's performance or non-performance of services under this Contract or the performance or non-performance of services under this Contract by anyone directly or indirectly employed by Contractor or for whose acts it may be liable. Such policies shall remain in full force and effect at all times during the term of this Agreement and shall contain the types of coverages and minimum limits which are required by the Supplemental General Conditions, Special General Conditions, or General Conditions, which shall, for this provision "Insurance" only, take precedence (in order of precedence as listed here) over this Agreement and other documents incorporated by reference. A certificate of insurance conforming to the requirements of the Supplemental, Special, and General Conditions shall be submitted prior to the execution of this Agreement.

30. Payment/Performance Bonds: Contractor shall furnish to the School Board a payment bond and a performance bond on forms provided by the School Board in conformity with Virginia Code §§ 2.2-4337 and 2.2-4339 each payable to the School Board and each in the sum of the Agreement amount. The performance bond shall be conditioned upon the faithful performance of the Agreement in strict conformity with the terms and conditions of the Agreement, and the payment bond shall be conditioned upon the prompt payment for all such material furnished or labor supplied or performed in the prosecution of the Work. Each of the bonds shall be executed by one or more surety companies selected by Contractor which are licensed and legally authorized to conduct the business of insurance, including surety, within the Commonwealth of Virginia. The performance and payment bonds shall be amended if necessary, as determined by the School Board, to reflect changes to the scope of the Work created by Change Orders and any amendments to this Agreement.

31. School Contractor Certification: Pursuant to Virginia Code § 22.1-296.1, Contractor certifies by his signature below that any and all persons who will provide services for or on behalf of the Contractor on public school property have not been convicted of a felony; any offense involving the sexual molestation, physical or sexual abuse or rape of a child; or any offense for which registration is required as defined in Virginia Code § 9.1-902. This Certification shall be binding throughout the contract term and that it will provide immediate notice to the School Board of any event that renders this certification untrue.

Contractor hereby acknowledges that any person making a materially false statement regarding any such offense shall be guilty of a class 1 misdemeanor and, upon conviction, the fact of such conviction shall be grounds for the revocation of this Agreement and, when relevant, the revocation of any license required to provide such services.

[Signature Page Follows]

**SCHOOL BOARD ACCEPTANCE**  
**The School Board of Albemarle County, Virginia**

**CONTRACTOR'S ACCEPTANCE**  
**[Contractor]**

SIGNATURE \_\_\_\_\_

SIGNATURE \_\_\_\_\_

NAME (type/print) Allison McNally

NAME (type/print) \_\_\_\_\_

TITLE Chief Procurement Officer

TITLE \_\_\_\_\_

DATE \_\_\_\_\_

DATE \_\_\_\_\_

**POST BID MODIFICATION**

**DATE:**

**PROJECT TITLE:**

**IFB NO.:**

**OWNER:**

**CONTRACTOR:**

As allowed by Section 12(c) of the Instructions to Bidders and by §2.2-4318, Code of Virginia, negotiations were conducted with the lowest responsive and responsible bidder, \_\_\_\_\_, hereinafter called the Contractor. The following clarifications, amendments, deletions, revisions, substitutions, and/or modifications to the Contract Documents were made along with corresponding adjustments in the Contractor’s bid amount for furnishing all labor and materials and performing all work necessary for construction of this project in accordance with the modified contract documents:

<b>Item</b>	<b>AMOUNT</b>
<b>TOTAL</b>	

**END OF POST BID MODIFICATION**

# STANDARD PERFORMANCE BOND FOR CONSTRUCTION CONTRACTS

**KNOW ALL BY THESE PRESENT:** That \_\_\_\_\_, the Contractor (“Principal”) whose principal place of business is located at \_\_\_\_\_ and \_\_\_\_\_ (“Surety”) are held and firmly bound unto the County of Albemarle, Virginia, and/or The School Board of Albemarle County, Virginia, the Owner (“Obligee”) in the amount of \_\_\_\_\_ for the payment whereof Principal and Surety bind themselves, their heirs, executors, administrators, successors and assigns, jointly and severally, firmly by these presents.

**WHEREAS,**

Principal has by written agreement dated \_\_\_\_\_, entered into a contract with Obligee for \_\_\_\_\_ which contract (the “Contract”) is by reference expressly made a part hereof;

**NOW THEREFORE, THE CONDITION OF THIS OBLIGATION** is such that, if the Principal shall promptly and faithfully perform said Contract in strict conformity with the plans, specifications and conditions of the Contract, then this obligation shall be null and void; otherwise it shall remain in full force and effect.

Provided, that any alterations which may be made in the terms of the Contract, or in the Work to be done under it, or the giving by the Obligee of any extension of the time for the performance of the Contract, or any other alterations, extensions or forbearance on the part of either or both of the Obligee or the Principal to the other shall not in any way release the Principal and the Surety, or either of them, their heirs, executors, administrators, successors or assigns from their liability hereunder, notice to the Surety of any such alterations, extension, or forbearance being hereby waived.

No action shall be brought on this bond unless brought within one year after: (a) completion of the Contract and all Work thereunder, including expiration of all warranties and guarantees, or (b) discovery of the defect or breach of warranty or guarantee if the action be for such.

The Surety represents to the Principal and to the Obligee that it is legally authorized to do business in the Commonwealth of Virginia.

**Signed and sealed** this \_\_\_\_\_ day of \_\_\_\_\_.

**PRINCIPAL**

\_\_\_\_\_

BY:

\_\_\_\_\_  
**(Please sign above and print name below)**

TITLE:

\_\_\_\_\_

ADDRESS:

\_\_\_\_\_

\_\_\_\_\_

\_\_\_\_\_

PHONE:

\_\_\_\_\_

**SURETY**

BY:

\_\_\_\_\_  
**(Please sign above and print name below)**

ADDRESS:

\_\_\_\_\_

\_\_\_\_\_

\_\_\_\_\_

PHONE:

\_\_\_\_\_

BOND NO.:

\_\_\_\_\_

ADDRESS OF SURETY'S HOME OFFICE:

\_\_\_\_\_

\_\_\_\_\_

\_\_\_\_\_

# STANDARD LABOR AND MATERIAL PAYMENT BOND

**KNOW ALL BY THESE PRESENT:** That \_\_\_\_\_, the Contractor (“Principal”) whose principal place of business is located at \_\_\_\_\_ and \_\_\_\_\_ (“Surety”) are held and firmly bound unto the County of Albemarle, Virginia, and/or The School Board of Albemarle County, Virginia, the Owner (“Obligee”) in the amount of \_\_\_\_\_ for the payment whereof Principal and Surety bind themselves, their heirs, executors, administrators, successors and assigns, jointly and severally, firmly by these presents.

**WHEREAS,**

Principal has by written agreement dated \_\_\_\_\_, entered into a contract with Obligee for \_\_\_\_\_ which contract (the “Contract”) is by reference expressly made a part hereof;

**NOW THEREFORE, THE CONDITION OF THIS OBLIGATION** is such that, if the Principal shall promptly make payment to all claimants as hereinafter defined, for labor performed and material furnished in the prosecution of the Work provided for in the Contract, then this obligation shall be void; otherwise it shall remain in full force and effect, subject, however, to the following conditions.

The Principal and Surety, jointly and severally, hereby agree with Obligee as follows:

1. A claimant is defined as one having a direct contract with the Principal or with a subcontractor of the Principal for labor, material, or both for use in the performance of the Contract. A “subcontractor” of the Principal, for the purposes of this bond only, includes not only those subcontractors having a direct contractual relationship with the Principal, but also any other contractor who undertakes to participate in the Work which the Principal is to perform under the aforesaid Contract, whether there are one or more intervening subcontractors contractually positioned between it and the Principal (for example, a subcontractor). “Labor” and “material” shall include, but not be limited to, public utility services and reasonable rentals of equipment, but only for periods when the equipment rented is actually used at the work site.
2. Subject to the provisions of paragraph 3, any claimant who has performed labor or furnished material in accordance with the Contract documents in the prosecution of the Work provided in the Contract, who has not been paid in full therefor before the expiration of ninety (90) days after the day on which such claimant performed the last of such labor or furnished the last of such materials for which he claims payment, may bring an action on this bond to recover any amount due him for such labor or material, and may prosecute such action to final judgment

and have execution on the judgment. The Obligee need not be a party to such action and shall not be liable for the payment of any costs, fees or expenses of any such suit.

3. Any claimant who has a direct contractual relationship with any subcontractor of the Principal from whom the Principal has not required a subcontractor payment bond, but who has no contractual relationship, express or implied, with the Principal, may bring an action on this bond only if he has given written notice to the Principal within one hundred eighty (180) days from the day on which the claimant performed the last of the labor or furnished the last of the materials for which he claims payment, stating with substantial accuracy the amount claimed and the name of the person for whom the Work was performed or to whom the material was furnished. Notice to the Principal shall be served by registered or certified mail, postage prepaid, in an envelope addressed to the Principal at any place where his office is regularly maintained for the transaction of business. Claims for sums withheld as retainages with respect to labor performed or materials furnished shall not be subject to the time limitations stated in this paragraph 3.
4. No suit or action shall be commenced hereunder by any claimant;
  - a. Unless brought within one year after the day on which the person bringing such action last performed labor or last furnished or supplied materials, it being understood, however, that if any limitation embodied in this bond is prohibited by any law controlling the construction hereof, the limitation embodied within this bond shall be deemed to be amended so as to be equal to the minimum period of limitation permitted by such law.
  - b. Other than in a Virginia court of competent jurisdiction, with venue as provided by statute, or in the United States District Court for the district in which the project, or any part thereof is situated.
5. The amount of this bond shall be reduced by and to the extent of any payment or payments made in good faith hereunder.

**Signed and sealed** this \_\_\_\_\_ day of \_\_\_\_\_, \_\_\_\_\_.

**PRINCIPAL**

\_\_\_\_\_

BY:

\_\_\_\_\_  
**(Please sign above and print name below)**

TITLE:

\_\_\_\_\_

ADDRESS:

\_\_\_\_\_

\_\_\_\_\_

\_\_\_\_\_

PHONE:

\_\_\_\_\_

**SURETY**

BY:

\_\_\_\_\_  
**(Please sign above and print name below)**

ADDRESS:

\_\_\_\_\_

\_\_\_\_\_

\_\_\_\_\_

PHONE:

\_\_\_\_\_

BOND NO.:

\_\_\_\_\_

ADDRESS OF SURETY'S HOME OFFICE:

\_\_\_\_\_

\_\_\_\_\_

\_\_\_\_\_



<b>CHANGE ORDER- (Construction or A/E Contract Modification)</b>	
<b>COUNTY OF ALBEMARLE, VIRGINIA</b>	
<b>CONTRACT NO.:</b>	<b>CONTRACTOR:</b>
0	
<b>CHANGE ORDER NO.:</b>	
<b>PROJECT TITLE:</b>	<b>PURCHASE ORDER NO.:</b>
0	
<b>FULL ACCOUNT CODE:</b>	<b>PROJECT MANAGER:</b>
<b>DESCRIPTION/JUSTIFICATION OF CHANGE ORDER:</b>	<b>AMOUNT:</b>
<b>Total Amount of PCOs</b>	<b>\$0.00</b>
<i>Contractor Proposal including Itemized Costs must be fully documented and attached to this form.</i>	
Original Contract Value	\$0.00
Net change by previously authorized Change Orders	\$0.00
Contract Sum prior to this Change Order	\$0.00
Contract Sum will be decreased/increased by this Change Order in the amount of	\$0.00
New Contract Sum including this Change Order will be	\$0.00
Percent of all Change Orders to Original Contract Value:	#DIV/0!
Does the sum of Change Orders exceed 25 % of the Original Contract Value and/or exceeds \$50,000.00? If yes, attach Executive approval	
Is a portion of this change caused by AE error and/or omission?	
Description of AE error and/or omission (if applicable):	
<p>Failure to include a change for time shall waive any change to the time allowed by the Contract for completion of the Work unless the parties mutually agree in writing to postpone a determination of the change to time resulting from the Change Order. Such determination may not be postponed more than 45 days from the approval of this Change Order by the Owner.</p>	
Contract Time will be increased by (Calendar Days):	
Date of Contract Completion as of the date of this Change Order therefore is:	1/0/1900
<p>By signing this Change Order, the Contractor agrees to release and waive any and all claims related to this Change Order.</p>	
<b>(1) Architect/Engineer</b>	Date:
<b>(2) Contractor (If applicable)</b>	Date:
<b>(3) Department Approval</b>	Date:
<b>(4) Chief of Procurement</b>	Date:

# GENERAL CONTRACTOR ESTIMATE FOR CHANGE ORDER

**GC-1**

IFB Number:       General Contractor:   
 Project:       Change Description:   
 Owner:       COR/PCO #:

GENERAL CONTRACTOR DIRECT COSTS											
Scope Description				Direct Labor				Direct Material		Direct Equipment	
Item No.	Description	Quantity	Qty Units	Direct Labor Hours Per Unit	Total Direct Labor Hours	Hourly Wage Rate, Excl. Taxes & Ins.	Total Labor Cost	Material Cost Per Unit	Total Material Cost	Equipment Cost Per Unit	Total Equipment Cost
A	B	C	D	E	F = C x E	G	H = F x G	I	J = C x I	K	L = C x K
1.01					0.00		\$0.00		\$0.00		\$0.00
1.02					0.00		\$0.00		\$0.00		\$0.00
1.03					0.00		\$0.00		\$0.00		\$0.00
1.04					0.00		\$0.00		\$0.00		\$0.00
1.05					0.00		\$0.00		\$0.00		\$0.00
1.06					0.00		\$0.00		\$0.00		\$0.00
1.07					0.00		\$0.00		\$0.00		\$0.00
1.08					0.00		\$0.00		\$0.00		\$0.00
1.09	<b>Subtotal from Estimate Continuation Sheets</b>						\$0.00		\$0.00		\$0.00
1.97	<b>Subtotal (S/T) Direct Costs:</b>					<b>Subtotal Labor</b>	<b>\$0.00</b>	<b>Subtotal Mat'l</b>	<b>\$0.00</b>	<b>Subtotal Equip.</b>	<b>\$0.00</b>
1.98	<b>Taxes/Insurance:</b>			FICA, FUI, SUI, & Workmens' Comp. at <span style="background-color: yellow; display: inline-block; width: 50px; height: 15px;"></span>		% of Item 1.97H =	\$0.00	Sales Tax @ 5.3%	\$0.00	Sales Tax @ 5.3%	\$0.00
1.99	<b>Total Direct Costs</b>					<b>Total Labor</b>	<b>\$0.00</b>	<b>Total Mat'l</b>	<b>\$0.00</b>	<b>Total Equip.</b>	<b>\$0.00</b>

SUBCONTRACT COSTS		
Item No.	Subcontractor Name (List totals from attached SC-1 forms)	Total Cost
A	B	C
2.01		
2.02		
2.03		
2.04		
2.05		
2.06		
2.07		
2.08		
2.09		
2.99	<b>Total Subcontract Costs</b>	<b>\$0.00</b>

SUMMARY		
Item No.	Description	Total Cost
3.01	Total Direct Labor Cost	Item 1.99H \$0.00
3.02	Total Direct Material Cost	Item 1.99J \$0.00
3.03	Total Equipment Cost	Item 1.99L \$0.00
3.04	Subtotal	3.01+3.02+3.03 \$0.00
3.05	Overhead and Profit	* 10% x Item 3.04 \$0.00
3.06	Subtotal	3.04+3.05 \$0.00
3.07	Subcontractor Cost	Item 2.99 \$0.00
3.08	GC Markup on Subcontractors	** 10% x Item 3.07 \$0.00
3.09	Subtotal	3.06+3.07+3.08 \$0.00
3.10	Additional Bond Cost	
3.99	<b>Total Change Order Cost</b>	(3.09+3.10) <b>\$0.00</b>

**Submitted By**

Name: \_\_\_\_\_

Signature: \_\_\_\_\_

Title: \_\_\_\_\_

Date: \_\_\_\_\_

I have reviewed the costs proposed and find them to be reasonable (as proposed) (as marked).

A/E Signature: \_\_\_\_\_

**Note:** Mark-up is capped in conformance with the provisions of Section 38(d) of the Construction Contract General Conditions.

\*Limited to 10% on subcontracted work.

\*\*Limited to a total of 10%, shared (cumulative total) if multiple tier subs, on subcontracted work.

# SUBCONTRACTOR ESTIMATE FOR CHANGE ORDER

SC-1

IFB Number:   
 Project:   
 Owner:

General Contractor:   
 Subcontractor:   
 Subcontractor Trade:   
 COR/PCO #:

Change Description:

SUBCONTRACTOR DIRECT COSTS											
Scope Description				Direct Labor				Direct Material		Direct Equipment	
Item No.	Description	Quantity	Qty Units	Direct Labor Hours Per Unit	Total Direct Labor Labor Hours	Hourly Wage Rate, Excl. Taxes & Ins.	Total Labor Cost	Material Cost Per Unit	Total Material Cost	Equipment Cost Per Unit	Total Equipment Cost
A	B	C	D	E	F = C x E	G	H = F x G	I	J = C x I	K	L = C x K
1.01					0.00		\$0.00		\$0.00		\$0.00
1.02					0.00		\$0.00		\$0.00		\$0.00
1.03					0.00		\$0.00		\$0.00		\$0.00
1.04					0.00		\$0.00		\$0.00		\$0.00
1.05					0.00		\$0.00		\$0.00		\$0.00
1.06					0.00		\$0.00		\$0.00		\$0.00
1.07					0.00		\$0.00		\$0.00		\$0.00
1.08					0.00		\$0.00		\$0.00		\$0.00
1.09	<b>Subtotal from Estimate Continuation Sheets</b>						\$0.00		\$0.00		\$0.00
1.97	<b>Subtotal (S/T) Direct Costs:</b>					<b>Subtotal Labor</b>	<b>\$0.00</b>	<b>Subtotal Mat'l</b>	<b>\$0.00</b>	<b>Subtotal Equip.</b>	<b>\$0.00</b>
1.98	<b>Taxes/Insurance:</b> FICA, FUI, SUI, & Workmens' Comp. at <span style="background-color: yellow; border: 1px solid black; display: inline-block; width: 50px; height: 15px;"></span>					% of Item 1.97H	\$0.00	Sales Tax @ 5.3%	\$0.00	Sales Tax @ 5.3%	\$0.00
1.99	<b>Total Direct Costs</b>					<b>Total Labor</b>	<b>\$0.00</b>	<b>Total Mat'l</b>	<b>\$0.00</b>	<b>Total Equip.</b>	<b>\$0.00</b>

SUB-SUBCONTRACT COSTS		
Item No.	Sub-Subcontractor Name (List totals from attached SS-1 forms)	Total Cost
A	B	C
2.01		
2.02		
2.03		
2.04		
2.05		
2.06		
2.99	<b>Total Sub-Subcontract Costs</b>	<b>\$0.00</b>

SUMMARY			
Item No.	Description		Total Cost
3.01	Total Direct Labor Cost	Item 1.99H	\$0.00
3.02	Total Direct Material Cost	Item 1.99J	\$0.00
3.03	Total Equipment Cost	Item 1.99L	\$0.00
3.04	Subtotal	3.01+3.02+3.03	\$0.00
3.05	Overhead and Profit	* 10% x Item 3.04	\$0.00
3.06	Total Subcontractor Cost	3.04+3.05	\$0.00
3.07	Sub-Subcontractor Cost **	Item 2.99	\$0.00
3.99	<b>S/C Cost Report'd to GC ***</b>	3.06+3.07	<b>\$0.00</b>

Submitted By

Name: \_\_\_\_\_  
 Signature: \_\_\_\_\_  
 Title: \_\_\_\_\_  
 Date: \_\_\_\_\_

**Note:** Mark-up is capped in conformance with the provisions of Section 38(d) of the Construction Contract General Conditions.

\* Limited to 10% on self-performed work.

\*\* Limited to a total of 10%, shared (cumulative total) if multiple tier subs, on subcontracted work. Total mark-up on subcontracted work is calculated on the GC-1 form.

\*\*\* The subcontractor cost carried forward to GC-1 form does not include mark-up on sub-subcontractor costs. This mark-up is calculated on the GC-1 form. The GC and its subcontractors shall determine the mark-up to be distributed among the various subcontractors involved in the work.



# SUB-SUBCONTRACTOR ESTIMATE FOR CHANGE ORDER

**SS-1**

IFB Number:   
 Project:   
 Owner:

General Contractor:   
 Subcontractor:   
 Sub-Subcontractor:   
 Sub-Subcontractor Trade:   
 COR/PCO #:

Change Description:

SUB-SUBCONTRACTOR DIRECT COSTS											
Scope Description				Direct Labor				Direct Material		Direct Equipment	
Item No.	Description	Quantity	Qty Units	Direct Labor Hours Per Unit	Total Direct Labor Labor Hours	Hourly Wage Rate, Excl. Taxes & Ins.	Total Labor Cost	Material Cost Per Unit	Total Material Cost	Equipment Cost Per Unit	Total Equipment Cost
A	B	C	D	E	F = C x E	G	H = F x G	I	J = C x I	K	L = C x K
1.01					0.00		\$0.00		\$0.00		\$0.00
1.02					0.00		\$0.00		\$0.00		\$0.00
1.03					0.00		\$0.00		\$0.00		\$0.00
1.04					0.00		\$0.00		\$0.00		\$0.00
1.05					0.00		\$0.00		\$0.00		\$0.00
1.06					0.00		\$0.00		\$0.00		\$0.00
1.07					0.00		\$0.00		\$0.00		\$0.00
1.08					0.00		\$0.00		\$0.00		\$0.00
1.09	<b>Subtotal from Estimate Continuation Sheets</b>						\$0.00		\$0.00		\$0.00
1.97	<b>Subtotal (S/T) Direct Costs:</b>					<b>Subtotal Labor</b>	<b>\$0.00</b>	<b>Subtotal Mat'l</b>	<b>\$0.00</b>	<b>Subtotal Equip.</b>	<b>\$0.00</b>
1.98	<b>Taxes/Insurance:</b> FICA, FUI, SUI, & Workmens' Comp. at <span style="background-color: yellow; border: 1px solid black; display: inline-block; width: 60px; height: 15px;"></span>					% of Item 1.97H	\$0.00	Sales Tax @ 5.3%	\$0.00	Sales Tax @ 5.3%	\$0.00
1.99	<b>Total Direct Costs</b>					<b>Total Labor</b>	<b>\$0.00</b>	<b>Total Mat'l</b>	<b>\$0.00</b>	<b>Total Equip.</b>	<b>\$0.00</b>

SUMMARY		
Item No.	Description	Total Cost
3.01	Total Direct Labor Cost <span style="float: right;">Item 1.99H</span>	\$0.00
3.02	Total Direct Material Cost <span style="float: right;">Item 1.99J</span>	\$0.00
3.03	Total Equipment Cost <span style="float: right;">Item 1.99L</span>	\$0.00
3.04	Subtotal <span style="float: right;">3.01+3.02+3.03</span>	\$0.00
3.05	Overhead and Profit <span style="float: right;">* 10% x Item 3.04</span>	\$0.00
3.99	<b>Total Sub-Subcontractor</b>	<b>\$0.00</b>

**Submitted By**

Name: \_\_\_\_\_  
 Signature: \_\_\_\_\_  
 Title: \_\_\_\_\_  
 Date: \_\_\_\_\_

Note: Materials prices are in conformance with the provisions of Section 38(d) of the Construction Contract General Conditions.  
 \*Limited to 10% on self-performed work.





ITEM NO.	ITEM DESCRIPTION	TOTAL VALUE	VALUE OF WORK COMPLETED			PERCENT COMPLETE	NOTES / COMMENTS
			PREVIOUS VALUE TO DATE	VALUE THIS REPORT	CURRENT VALUE TO DATE		
		\$ -	\$ -	\$ -	\$ -	0%	
		\$ -	\$ -	\$ -	\$ -	0%	
		\$ -	\$ -	\$ -	\$ -	0%	
		\$ -	\$ -	\$ -	\$ -	0%	
		\$ -	\$ -	\$ -	\$ -	0%	
		\$ -	\$ -	\$ -	\$ -	0%	
		\$ -	\$ -	\$ -	\$ -	0%	
		\$ -	\$ -	\$ -	\$ -	0%	
		\$ -	\$ -	\$ -	\$ -	0%	
		\$ -	\$ -	\$ -	\$ -	0%	
		\$ -	\$ -	\$ -	\$ -	0%	
		\$ -	\$ -	\$ -	\$ -	0%	
		\$ -	\$ -	\$ -	\$ -	0%	
		\$ -	\$ -	\$ -	\$ -	0%	
	Do not insert rows below this point !	\$ -	\$ -	\$ -	\$ -	0%	
<b>TOTAL ORIGINAL CONTRACT</b>		<b>\$ -</b>	<b>\$ -</b>	<b>\$ -</b>	<b>\$ -</b>	<b>0%</b>	



CHNG ORD. NO.	ITEM DESCRIPTION	TOTAL VALUE	VALUE OF WORK COMPLETED			PERCENT COMPLETE	NOTES / COMMENTS
			PREVIOUS VALUE TO DATE	VALUE THIS REPORT	CURRENT VALUE TO DATE		
		\$ -	\$ -	\$ -	\$ -	0%	
		\$ -	\$ -	\$ -	\$ -	0%	
		\$ -	\$ -	\$ -	\$ -	0%	
		\$ -	\$ -	\$ -	\$ -	0%	
		\$ -	\$ -	\$ -	\$ -	0%	
		\$ -	\$ -	\$ -	\$ -	0%	
		\$ -	\$ -	\$ -	\$ -	0%	
		\$ -	\$ -	\$ -	\$ -	0%	
		\$ -	\$ -	\$ -	\$ -	0%	
		\$ -	\$ -	\$ -	\$ -	0%	
		\$ -	\$ -	\$ -	\$ -	0%	
		\$ -	\$ -	\$ -	\$ -	0%	
		\$ -	\$ -	\$ -	\$ -	0%	
		\$ -	\$ -	\$ -	\$ -	0%	
	Do not insert rows below this point !	\$ -	\$ -	\$ -	\$ -	0%	
<b>TOTAL APPROVED CHANGE ORDERS</b>		\$ -	\$ -	\$ -	\$ -	<b>0%</b>	

**AFFIDAVIT OF PAYMENT OF CLAIMS**

**By:**

This day \_\_\_\_\_ personally appeared before me, \_\_\_\_\_, a Notary Public in and for the City/County of \_\_\_\_\_, \_\_\_\_\_ and, being by me first duly sworn, states that all subcontractors and suppliers of labor and materials have been paid all sums due them for work performed or materials furnished in the performance of the Contract between the County of Albemarle, Virginia, and/or The School Board of Albemarle County, Virginia, Owner, and \_\_\_\_\_, Contractor, dated \_\_\_\_\_, 20\_\_\_\_, for the construction of \_\_\_\_\_, \_\_\_\_\_, or arrangements have been made by the Contractor satisfactory to such subcontractors and suppliers with respect to payments of such sums as may be due them by the Contractor.

\_\_\_\_\_  
(Contractor Name)

By: \_\_\_\_\_

Print Name: \_\_\_\_\_

Title: \_\_\_\_\_

**ARCHITECT/ENGINEER'S CERTIFICATE OF SUBSTANTIAL COMPLETION**

**Date:** \_\_\_\_\_

County of Albemarle, Virginia, and/or  
The School Board of Albemarle County, Virginia  
c/o Facilities & Environmental Services – Facilities Planning & Construction Division  
401 McIntire Road  
Charlottesville, Virginia 22902-4596

**Project Title:** \_\_\_\_\_

**RFQ/Contract No.:** \_\_\_\_\_

In accordance with the requirements of the Contract Between Owner and Architect/Engineer and based upon the knowledge gained in the performance of the architectural/engineering services provided in said Contract and the reports of the Owner's Inspection and Testing entities, the undersigned Architect/Engineer states that the following portions of the project named above are substantially complete in accordance with the requirements of the Contract Documents and are recommended for use of their intended purpose (*indicate portions which are ready for use and, if applicable, occupancy*):

\_\_\_\_\_  
\_\_\_\_\_  
\_\_\_\_\_  
\_\_\_\_\_  
\_\_\_\_\_

All applicable tests, certificates and regulatory inspections required by the Contract Documents and any local, state or federal regulations have been performed with respect to the substantially completed portions of the project and the Owner has been provided with a copy of each report, except for the following:

\_\_\_\_\_  
\_\_\_\_\_  
\_\_\_\_\_  
\_\_\_\_\_

A tentative list of unfinished Work and defective Work, referred to as the "punch list," is attached hereto. The list may not be all-inclusive, and the failure to include an item in it does not alter the responsibility of the Contractor to complete all the Work in accordance with the Contract Documents. The items in the tentative list shall be completed or corrected by the Contractor within \_\_\_\_\_ days of the above date of Substantial Completion.

\_\_\_\_\_  
(A/E Firm Name)

By: \_\_\_\_\_

Print Name: \_\_\_\_\_

Title: \_\_\_\_\_

Attachment: Punch List

**CERTIFICATE OF FINAL COMPLETION BY ARCHITECT/ENGINEER**

**Date:** \_\_\_\_\_

County of Albemarle, Virginia, and/or  
The School Board of Albemarle County, Virginia  
c/o Facilities & Environmental Services – Facilities Planning & Construction Division  
401 McIntire Road  
Charlottesville, Virginia 22902-4596

**Project Title:** \_\_\_\_\_

**RFQ/Contract No.:** \_\_\_\_\_

In accordance with the requirements of the Contract Between the Owner and the Architect/Engineer for Professional Services and based upon the knowledge gained in the performance of the services required in said Agreement, the undersigned hereby states that the above named project was fully completed in accordance with the requirements of the Contract Documents on \_\_\_\_\_ (Month) \_\_\_\_\_ (Day), \_\_\_\_\_ (Year).

All applicable tests, certificates and regulatory inspections required by the Contract Documents and any local, state or federal regulations have been performed and the Owner has been provided with a copy of each report.

Final as-built drawings have been prepared by the Architect/Engineer and submitted to the Owner in accordance with the requirements of the Contract Documents. The Owner has been provided with a copy of all warranties and guarantees, including the starting date(s) of all warranties and guarantees, written and unwritten, required by the Contract Documents.

\_\_\_\_\_  
(A/E Firm Name)

By: \_\_\_\_\_

Print Name: \_\_\_\_\_

Title: \_\_\_\_\_

**CERTIFICATE OF PARTIAL OR SUBSTANTIAL COMPLETION BY CONTRACTOR**

**Date:** \_\_\_\_\_

County of Albemarle, Virginia, and/or  
The School Board of Albemarle County, Virginia  
c/o Facilities & Environmental Services – Facilities Planning & Construction Division  
401 McIntire Road  
Charlottesville, Virginia 22902-4596

**Project Title:** \_\_\_\_\_

**RFQ/Contract No.:** \_\_\_\_\_

In accordance with the requirements of the Agreement between the Owner and the Contractor, the undersigned Contractor hereby states that portions of the above named project are substantially completed in accordance with the requirements of the Contract Documents as modified by approved change orders. Those portions of the project now substantially complete are:

\_\_\_\_\_  
\_\_\_\_\_  
\_\_\_\_\_

All applicable tests, certificates and regulatory inspections required by the Contract Documents and any local, state or federal regulations have been performed with respect to the substantially completed portions of the project and the Owner has been provided with a copy of each report.

As-built marked up prints of the substantially completed portions of the project have been provided to the Architect/Engineer as required by the Contract Documents.

The Owner has been provided with a copy of all warranties and guarantees, including the starting date(s) of all warranties and guarantees, written and unwritten, required by the Contract Documents with respect to the completed portions of the project, except as follows:

\_\_\_\_\_  
\_\_\_\_\_  
\_\_\_\_\_

All training, operating instructions and maintenance manuals required by the Contract Documents have been provided to the Owner, except as follows:

\_\_\_\_\_  
\_\_\_\_\_  
\_\_\_\_\_

This certificate does not constitute an acceptance of Work not in accordance with the Contract Documents nor is it a release of CONTRACTOR’S obligation to complete the Work in accordance with the Contract Documents.

\_\_\_\_\_  
(Contractor Name)

By: \_\_\_\_\_

Print Name: \_\_\_\_\_

Title: \_\_\_\_\_

**CERTIFICATE OF FINAL COMPLETION BY CONTRACTOR**

**Date:** \_\_\_\_\_

County of Albemarle, Virginia, and/or  
The School Board of Albemarle County, Virginia  
c/o Facilities & Environmental Services – Facilities Planning & Construction Division  
401 McIntire Road  
Charlottesville, Virginia 22902-4596

**Project Title:** \_\_\_\_\_

**RFQ/Contract No.:** \_\_\_\_\_

In accordance with the requirements of the Contract Between Owner and Contractor (Form AC-9) the undersigned Contractor hereby states that the above named project has been fully completed in accordance with the requirements of the Contract Documents as modified by approved change orders.

All applicable tests, certificates and regulatory inspections required by the Contract Documents and any local, state or federal regulations have been performed with respect to the completed project and the Owner has been provided with a copy of each report.

As-built marked up prints of the completed project have been provided to the Architect/Engineer as required by the Contract Documents.

The Owner has been provided with a copy of all warranties and guarantees, including the starting date(s) of all warranties and guarantees, written and unwritten, required by the Contract Documents.

All training, operating instructions and maintenance manuals required by the Contract Documents have been provided to the Owner.

\_\_\_\_\_  
(Contractor Name)

By: \_\_\_\_\_

Print Name: \_\_\_\_\_

Title: \_\_\_\_\_

Copy: Architect/Engineer



# Code of Conduct

## Albemarle County School District Food Service Department

**Policy Name:** Written Code of Conduct

**Regulations:** 2 CFR Part 200.318, formerly 7 CFR Part 3016.36(b)(3), State Procurement Code and Regulations, and Albemarle County School District Department of Purchasing.

**Procedures:** The Albemarle County School District seeks to conduct all procurement procedures:

- in compliance with stated regulations; and
- to prohibit conflicts of interest and actions of employees engaged in the selection, award and administration of contracts.

No employee, officer, or agent may participate in the selection, award, or administration of a contract supported by a federal, state, or local award if he or she has a real or apparent conflict of interest. Such a conflict of interest would arise when the employee, officer, or agent, any member of his or her immediate family, his or her partner, or an organization which employs or is about to employ any of the parties indicated herein, has a financial or other interest in or a tangible personal benefit from a firm considered for a contract.

The officers, employees, and agents of the non-federal entity may neither solicit nor accept gratuities, favors, or anything of monetary value from contractors or parties to subcontracts. However, non-federal entities may set standards for situations in which the financial interest is not substantial or the gift is an unsolicited item of nominal value.

The standards of conduct must provide for disciplinary actions to be applied for violations of such standards by officers, employees, or agents of the non-federal entity. Based on the severity of the infraction, the penalties could include a written reprimand to their personnel file, a suspension with or without pay, or termination.

For questions and concerns regarding procurement solicitations, contract evaluations, and award, contact:

Director of School Food Service, Christina Pitsenberger 434-295-0566

All contracts, awarded by a recipient including small purchases, shall contain the following provisions as applicable:

1. *Equal Employment Opportunity*—All contracts shall contain a provision requiring compliance with E.O. 11246, “Equal Employment Opportunity,” as amended by E.O. 11375, “Amending Executive Order 11246 Relating to Equal Employment Opportunity,” and as supplemented by regulations at 41 CFR part 60, “Office of Federal Contract Compliance Programs, Equal Employment Opportunity, Department of Labor.”

2. *Copeland “Anti-Kickback” Act (18 U.S.C. 874 and 40 U.S.C. 276c)*—All contracts and subgrants in excess of \$2000 for construction or repair awarded by recipients and subrecipients shall include a provision for compliance with the Copeland “Anti-Kickback” Act (18 U.S.C. 874), as supplemented by Department of Labor regulations (29 CFR part 3, “Contractors and Subcontractors on Public Building or Public Work Financed in Whole or in Part by Loans or Grants from the United States”). The Act provides that each contractor or subrecipient shall be prohibited from inducing, by any means, any person employed in the construction, completion, or repair of public work, to give up any part of the compensation to which he is otherwise entitled. The recipient shall report all suspected or reported violations to the Federal awarding agency.

4. *Contract Work Hours and Safety Standards Act (40 U.S.C. 327-333)*—Where applicable, all contracts awarded by recipients in excess of \$2000 for construction contracts and in excess of \$2500 for other contracts that involve the employment of mechanics or laborers shall include a provision for compliance with Sections 102 and 107 of the Contract Work Hours and Safety Standards Act (40 U.S.C. 327-333), as supplemented by Department of Labor regulations (29 CFR part 5). Under Section 102 of the Act, each contractor shall be required to compute the wages of every mechanic and laborer on the basis of a standard work week of 40 hours. Work in excess of the standard work week is permissible provided that the worker is compensated at a rate of not less than 1½ times the basic rate of pay for all hours worked in excess of 40 hours in the work week. Section 107 of the Act is applicable to construction work and provides that no laborer or mechanic shall be required to work in surroundings or under working conditions which are unsanitary, hazardous or dangerous. These requirements do not apply to the purchases of supplies or materials or articles ordinarily available on the open market, or contracts for transportation or transmission of intelligence.

5. *Rights to Inventions Made Under a Contract or Agreement*—Contracts or agreements for the performance of experimental, developmental, or research work shall provide for the rights of the Federal Government and the recipient in any resulting invention in accordance with 37 CFR part 401, “Rights to Inventions Made by Nonprofit Organizations and Small Business Firms Under Government Grants, Contracts and Cooperative Agreements,” and any implementing regulations issued by the awarding agency.

6. *Clean Air Act (42 U.S.C. 7401 et. seq.) and the Federal Water Pollution Control Act (33 U.S.C. 1251 et seq.), as amended*—Contracts and subgrants of amounts in excess of \$100,000 shall contain a provision that requires the recipient to agree to comply with all applicable standards, orders or regulations issued pursuant to the Clean Air Act (42 U.S.C. 7401 et seq.) and the Federal Water Pollution Control Act as amended (33 U.S.C. 1251 et seq.). Violations shall be reported to the Federal awarding agency and the Regional Office of the Environmental Protection Agency (EPA).

7. *Byrd Anti-Lobbying Amendment (31 U.S.C. 1352)*—Contractors who apply or bid for an award of \$100,000 or more shall file the required certification. Each tier certifies to the tier above that it will not and has not used Federal appropriated funds to pay any person or organization for influencing or attempting to influence an officer or employee of any agency, a member of Congress, officer or employee of Congress, or an employee of a member of Congress in connection with obtaining any Federal contract, grant or any other award covered by 31 U.S.C. 1352. Each tier shall also disclose any lobbying with non-Federal funds that takes place in connection with obtaining any Federal award. Such disclosures are forwarded from tier to tier up to the recipient.

8. *Debarment and Suspension (E.O.s 12549 and 12689)*—All parties doing business with the Department of Agriculture should consult the Department's regulations for debarment and suspension found at 7 CFR 3017. No contract shall be made to parties listed on the General Services Administration's List of Parties Excluded from Federal Procurement or Nonprocurement Programs in accordance with E.O.s 12549 and 12689, “Debarment and Suspension.” This list contains the names of parties debarred, suspended, or otherwise excluded by agencies, and contractors declared ineligible under statutory or regulatory authority other than E.O. 12549. Contractors with awards that exceed the small purchase threshold shall provide the required certification regarding its exclusion status and that of its principal employees

#### Buy American Provision

All solicitations that involve the purchasing of a food component shall include a requirement that the SFA purchase domestic commodities to the maximum extent practicable and shall include procedures for limited exceptions. The SFA shall include following language in solicitations:

The LEA participates in the National School Lunch Program and School Breakfast Program and is required to use the nonprofit food service funds, to the maximum extent practicable, to buy domestic commodities or products for Program meals. A ‘domestic commodity or product’ is defined as one that is either produced in the U.S. or is processed in the U.S. substantially using agricultural commodities that are produced in the U.S. as provided in 7 CFR 210.21(d).

## **Agnor Hurt Elementary School Specifications**

**Provide one each two compartment convection steamer, - Basis of design - Cleveland Model 24CGA10.2 with the following features:**

1. Heavy Duty stainless steel 14 gauge construction
2. 10 pan capacity
3. Must have two independent cooking compartments with high efficiency gas power burner generators
4. Must have ball valve drain control. No drain solenoid.
5. Must have compensating timers.
6. Must have two piece compartment door design.
7. Provide Optipure WBT-QT11-CR water filter system
8. 3<sup>rd</sup> year parts and labor warranty
9. Provide Dormont 1675NPKIT48 Gas connector kit
10. Natural gas

Vendor to remove existing steamer and take to loading dock. Vendor to receive, deliver, uncrate and install new steamer and filter. Vendor to provide all final electrical, gas, water and drain connections.

**Provide a double deck combi oven consisting of (2) Each Gas, 6 pan, boiler based combi ovens - Basis of design - Cleveland Convotherm Model C4eT-6.20GB with the following features and scope of work:**

1. Disappearing door features which enables oven door to be slid back beside the oven. This allows the door to be out of the way when loading and unloading the oven for safety, labor savings, efficiency, and convenience.
1. Hands free fully automatic cleaning system with Eco, regular, and express modes. Cleaning chemicals must be in liquid form, and include a cleaner (Convoclean) and a neutralizer (Convocare). No manual handling of sprays or pucks will be allowed for safety and labor saving reasons. Automatic cleaning system will also go into a forced rinse for three minutes if the cleaning cycle is interrupted for any reason such as power outage. This will insure that no cleaning chemicals are ever allowed to remain in the cooking cavity. System to also have single-dose dispensing option.
2. Advanced Closed System +.
3. Crisp and Tasty demoisturizing feature with five moisture removal settings that can be programmed into recipes.

4. Easy Touch controls with 9" full screen, 399 cooking profiles with up to 20 steps for each recipe, Press and Go quick select buttons, and tray timer - oven load management for different products at the same time.
5. USB port for easy downloading or uploading of recipes.
6. Capacity of (6) 18" x 26" sheet pans or (12) 12" x 20" x 2-1/2" deep full size steam table pans.
7. Retractable hand shower for spraying and cleaning oven compartment.
8. Antibacterial door handle which contains silver ions to stop the growth of microorganisms.
9. BakePro- five levels of traditional baking.
10. HumidityPro – five levels of humidity settings,
11. Auto reversing fan for even cooking with five speeds.
12. Vented double glass door with hinged inner glass that snaps out for easy cleaning.
13. Multi- point core temperature probe that uses the lowest reading to control the cooking process.
14. Two each Optipure Model QT1+CR filter systems
15. (12) wire shelves.
16. (12) CWB-10 wire frying baskets - 12" x 20".
17. Provide stacking kit with 13.8" base, model 3431606 which is compatible with chemical drawer
18. Provide model 3471200 chemical drawer
19. Provide (2) each 11000115805 Installation Kits (one per combi deck)
20. Three year parts and labor warranty.
21. Natural gas

Vendor to remove existing double deck convection ovens and take to loading dock. Vendor to receive, deliver, uncrate and install new double deck combi and filter. Vendor to provide all final electrical, water and drain connections.

# SteamCraft® Gemini™ 10

TWO COMPARTMENT FLOOR MODEL DESIGN. PRESSURELESS  
CONVECTION STEAMER, TWIN, INDEPENDENT GAS-FIRED GENERATORS

Project \_\_\_\_\_  
 Item \_\_\_\_\_  
 Quantity \_\_\_\_\_  
 FCSI Section 11400 \_\_\_\_\_  
 Approved \_\_\_\_\_  
 Date \_\_\_\_\_

SteamCraft® Generator Style High Speed Convection Steamers

## Models

- 24-CGA-10.2



## Standard Features

- Cooking Capacity for up to ten 12" x 20" x 2 1/2" deep Cafeteria Pans, five each compartment.
- Totally independent cooking compartments, each has its' own generator, gas valve and water level controls - no shared components
- Exclusive High Efficiency Gas Power Burner (forced air) Generator: Produces more steam for faster cooking while lowering operating costs (72M BTU's per compartment)
- Easy Access Cleaning Port: Each generator has a delimiting port located on the outside, top of the unit
- Generator Steam Standby Mode: Holds generator at a steaming temperature, allows unit to start cooking quickly
- Each compartment has one, 60-Minute Electro-Mechanical Timer with "SureCook" load compensating feature. Manual Bypass Switch for constant steaming.
- Durable 14 Gauge, 304 Stainless Steel construction for cooking cavity and steam generator
- Exclusive Two-Piece Compartment door: Slammable, self-adjusting door provides and airtight seal, reversable door gasket for extended life
- Exclusive Gemini Drain/Power Control System: Simple, reliable 1/2" ball valve style drain automatically turns power ON/OFF
- Exclusive Brass Steam Jets distribute even-high velocity steam throughout cooking compartment for faster cooking times
- Easy, Front -Access Generator Controls comes with a pullout drawer for simple servicing of unit
- 6" Stainless Steel Adjustable Legs with Flanged Feet
- Approvals: CSA (AGA, CSA) and U.L./NSF#4
- Compartment Steam Shut-Off Switch when compartment door is opened

## Short Form Specifications

Shall be Two Compartments, Cleveland Convection Steamer series SteamCraft® Gemini™ 10, Model 24-CGA-10.2, Twin Gas Atmospheric Steam Generator, 72M BTU's input per compartment. Independent steam generator, gas valve and water level control system. Automatic Generator Blowdown. Steam Generator with Automatic Water Fill on start up. Exclusive remote probe-type water level controls. Exclusive Brass "Steam Jet" distribution system. Two-piece free-floating compartment door. Type 430 Stainless Steel exterior and cooking compartments. Pullout service drawer for controls and Gemini Drain/Power Control System. Exclusive Cold Water Condenser design. Choice of Compartment Controls. Manual By Pass for continuous steaming.

## Options & Accessories

- Electronic Timer with Compensating Feature (ETC)
- Propane Gas (PG)
- Dissolve® Descale Solution, 6 one gallon container w/ quart markings (106174)
- Water Filters
- Hinged Right Door, controls on right

KE004046-23

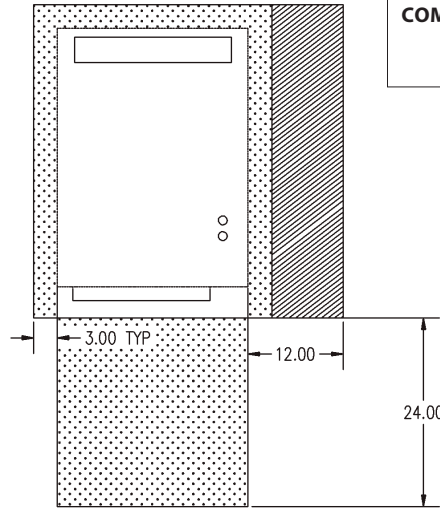
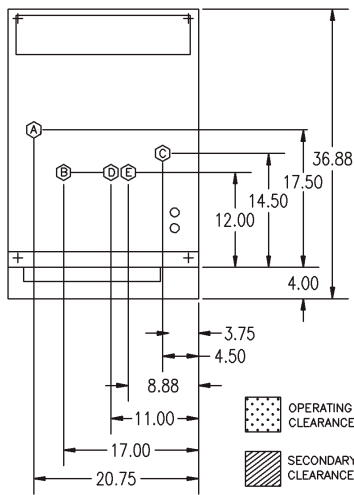

**COMPARTMENT HAS CAPACITY FOR:**

- Five, 12" x 20" x 2 1/2" deep Cafeteria Pans

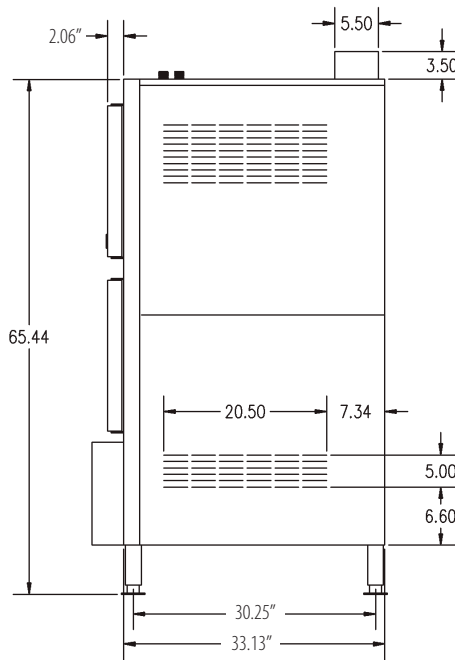
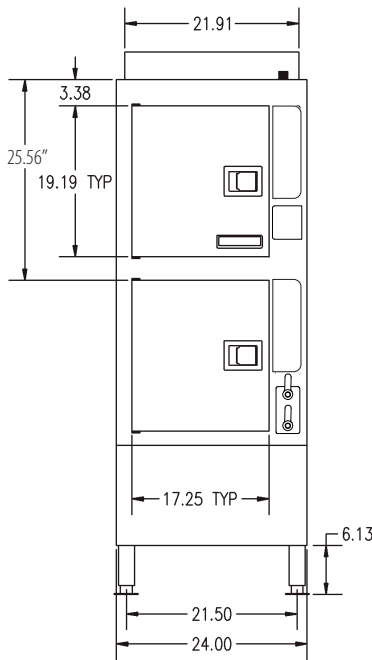

WATER QUALITY REQUIREMENTS (Boilers, Generators)	
TTDS:	50-250 ppm
Hardness:	50 - 200 mm (3 - 12 gpg)
pH value:	7.0 - 8.5
CL (Chloride):	max 50 ppm
Cl2 (free chlorine):	max 0.1 ppm
SiO2 (silica):	max 13 ppm
NH2Cl: (mono-chloramine)	max 0.1 ppm
Total Alkalinity:	50 - 100 ppm

A GAS			B ELECTRIC	CD COLD WATER	CLEARANCE	D DRAINAGE
1 1/4" IPS line size, 3/8" connection			120V-1Phase, 60 Hz. 2 Blowers & Controls 150 watts each  ** Do not connect to GFI outlet. See note below.	35 psi minimum 60 psi maximum  1/2" IPS-M NPT for Generator  1/2" IPS-M NPT for Condenser	Right - 3", Left - 3", Rear - 3"  (12" on control side if adjoining wall or equipment is over 30" high for service access)  <b>Contact factory for variances to clearances.</b>	1/2" IPS-M  Do not connect other units to this drain  Drain must not be located beneath the steamer itself  Preferred floor drain location should be a minimum distance (from the unit) of at least 12" from the left side, 12" from the right side, 6" from the front and 6" from the rear.  Do not use PVC pipe
NATURAL	PROPANE	BTU				
Piping 3/8" N.P.T.	Piping 3/8" N.P.T.	72,000 each				
Supply pressure	Supply pressure	Generator,				
4.50" W.C. Min.	11.00" W.C. Min.	144,000 total				
14.00" W.C. Max.	14.00" W.C. Max.					
Manufacturer must be notified if unit will be used above 2,000 feet						

**NOTES:**  
 \*\*DO NOT CONNECT TO GFI OUTLET. CLEVELAND RANGE RECOMMENDS GAS FIRED 120 VOLT STEAMERS BE HARD WIRED DIRECTLY TO ELECTRICAL SYSTEM.  
 Cleveland Range reserves right of design improvement or modification, as warranted.  
 Many regional, state and local codes exist and it is the responsibility of the owner and installer to comply with the codes.  
 Cleveland Range equipment is built to comply with applicable standards for manufacturers. Included among those approval agencies are U.L./NSF#4 and CSA (AGA, CGA).

(NOT TO SCALE)

# Combi steamer

Project \_\_\_\_\_  
 Item \_\_\_\_\_  
 Quantity \_\_\_\_\_  
 FCSI section \_\_\_\_\_  
 Approval \_\_\_\_\_  
 Date \_\_\_\_\_

C4eT 6.20 GB

## Model

Convotherm 4 easyTouch

- easyTouch
- 7 slide rails
- Gas
- Boiler
- Right-hinged door



## Key features

- ACS+ operating modes: Steam, combi-steam, hot air
- ACS+ extra functions:
  - Crisp&Tasty - 5 moisture-removal settings
  - BakePro - 5 levels of traditional baking
  - HumidityPro - 5 humidity settings
  - Controllable fan - 5 speed settings
- easyTouch 9" full-touch screen
- ConvoClean+ fully automatic cleaning system with eco, regular and express modes - with optional single-dose dispensing
- Ethernet interface (LAN)
- HygienicCare
- USB port integrated in the control panel
- TriColor indicator ring - indicates the current operating status
- Steam generated by high-performance boiler outside the cooking chamber
- Right-hinged door

## Standard features

- ACS+ (Advanced Closed System +) operating modes:
  - Steam (86-266°F) with guaranteed steam saturation
  - Combi-steam (86-482°F) with automatic humidity adjustment
  - Hot air (86-482°F) with optimized heat transfer
- HygienicCare - food safety provided by antibacterial surfaces:
  - easyTouch control panel
  - Door handle and recoil hand shower
- easyTouch user interface:
  - 9" full-touch screen
  - Press&Go - automatic cooking with quick-select buttons
  - TrayTimer - oven-load management for different products at the same time
  - Regenerate+ - flexible multi-mode retherm function
  - ecoCooking - energy-save function
  - Low-temperature cooking / Delta-T cooking
  - Cook&Hold - cook and hold in one process
  - 399 cooking profiles each containing up to 20 steps
  - On-screen help with topic-based video function
  - Start-time preset
- Multi-point core temperature probe
- Door handle with safety latch and slam function
- Data storage for HACCP and pasteurization figures
- Preheat and Cool down function

## Options

- Disappearing door – more space and added safety (see page 2)
- ConvoGrill with grease management function (upon request)
- ConvoSmoke - built in food-smoking
- Available in various voltages
- Sous-vide probe, external connection
- Core temperature probe, external connection

## Accessories

- ConvoLink HACCP and cooking-profile management PC software
- Signal tower - indicates the operating status from a distance
- Banquet system (optionally as a package or individually): Plate rack, mobile shelf rack, transport trolley, thermal cover
- Equipment stands in various sizes and designs
- Racks for cooking and baking
- Stacking kits
- Cleaning products for the fully automatic ConvoClean+ cleaning system and the semi-automatic cleaning system



**Front view**

(disappearing door optional)

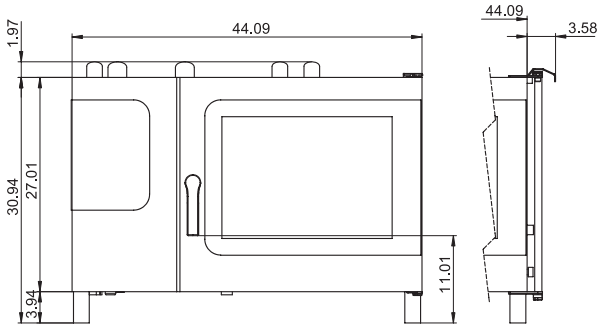

**Connection positions**

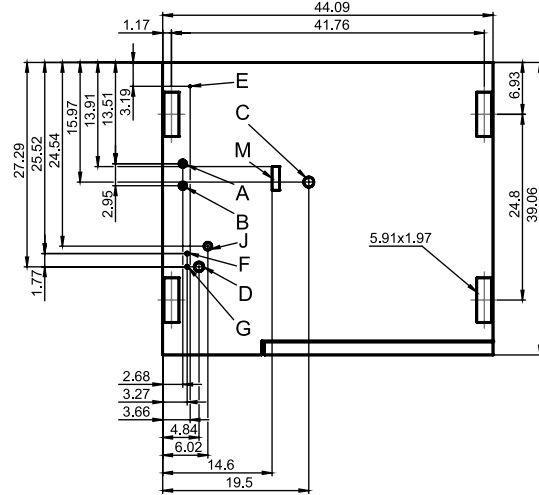

**View from above with wall clearances**

(disappearing door optional)

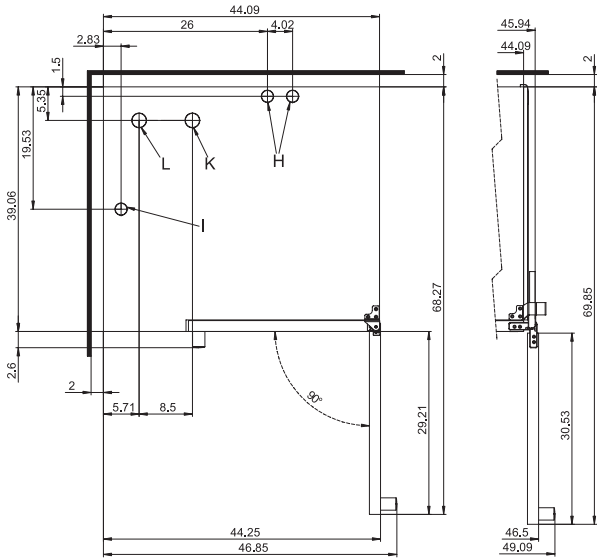

- A** Water connections (for boiler)
- B** Water connections (for cleaning, recoil hand shower)
- C** Drain connection (2" I. D.)
- D** Electrical connection
- E** Electrical ground
- F** Rinse-aid connection
- G** Cleaning-agent connection
- H** Air vent (2" I. D.)
- I** Ventilation port
- J** Gas connection
- K** Exhaust outlet (cooking compartment heating element)
- M** Safety overflow 3.2" x 1"

**Installation requirements**

Max. absolute appliance inclination during operation\* max. 2° (3.4%)

\* Adjustable appliance feet as standard.

**Dimensions and weights**

**Dimensions including packaging**

Width x Height x Depth 53" x 39.8" x 44.9"

**Weight**

Net weight without options\* / accessories 437 lbs

Packaging weight 66 lbs

**Safety clearances\*\***

Rear	2"
Right (right-hinged door)	2"
Right (disappearing door pushed back)	5"
Left (18" clearance recommended for service)	2"
Top***	39"

\* Max. weight of options: 42 lbs.

\*\* Minimum clearance from heat sources: 20".

\*\*\* Depends on the type of exhaust system and the ceiling's characteristics.

### Loading capacity

**Max. number of food containers**

[Unit has 7 slide rails; rail spacing 2.68" max.]

Steam table pans (12"x20"x1")	12
Steam table pans (12"x20"x2.5")	12
Wire shelves, full size (20"x26")	6
Sheet pans, full size (18"x26")*	6
Sheet pans, half size (12"x20")*	12
Frying baskets, half size (12"x20")	12
Plates (optional plate rack)	27

**Max. loading weight**

Per combi steamer	132 lbs
Per shelf level	33 lbs

\* Wire shelves required.

### Electrical supply

**120V 1PH 60Hz \***

Rated power consumption	0.6 kW
Rated current	7.5 A
Power supply wire gauge	14 AWG
Conductor insulation rating	194°F / 90°C

\* Prepared for connection to an energy optimizing system.

### Water connections

**Water supply**

Water supply Two 3/4" I. D. GHT-M (garden hose adapter). The appliance is designed for a permanent hookup to the water supply that uses a connecting hose with a minimum diameter of 1/2"

Flow pressure 22 - 87 PSI / 1.5 - 6 bar

**Drain**

Drain version Permanent hookup (recommended) or funnel waste trap

Type 2" I. D. (comes elbow-shaped as standard)

Slope for drainpipe min. 3.5% (2°)

### Water quality

**Water connection A\* for boiler, Water connection B\* for cleaning, recoil hand shower**

General requirements	Drinking water, typically untreated water
TDS	70 - 360 ppm
Hardness	70 - 360 ppm (4 - 21 gpg)
pH value	6.5 - 8.5
Cl <sup>-</sup> (chloride)	max. 60 ppm
Cl <sub>2</sub> (free chlorine)	max. 0.2 ppm
SO <sub>4</sub> <sup>2-</sup> (sulfate)	max. 150 ppm
Fe (iron)	max. 0.1 ppm
SiO <sub>2</sub> (silica)	max. 13 ppm
NH <sub>2</sub> Cl (monochloramine)	max. 0.4 ppm
Temperature	max. 104°F / max. 40°C

\* See connection positions diagram, p. 2.

NOTICE: The owner/operator/purchaser must ensure that the water quality requirements are met. Otherwise the original equipment warranty is void.

### Emissions

**Heat emission**

Latent	3400 BTU/h
Sensitive	3900 BTU/h

<b>Drain temperature</b>	max. 140°F / 60°C
--------------------------	-------------------

<b>Decibel rating</b>	max. 70 dBA
-----------------------	-------------

### Water consumption

**Water connections A, B**

Average consumption for cooking**	1.90 gph
Required flow rate	3.96 gpm

\*\* Incl. water required for cooling the wastewater.

NOTICE: See connection positions diagram, p. 2.

### Gas specifications

Type of gas	Natural gas, propane
Gas connection	1/2" NPT

**Flow pressure**

Natural gas	5.5 - 14" WC
Propane	11 - 14" WC

**Heat output** For Natural gas, propane

Convection burner	68200 BTU/h
Boiler burner	61400 BTU/h

**Please note:**

- Please refer to the Installation manual for further technical data and for instructions on installation and setup.
- Convotherm reserves the right of design improvement or modification, as warranted.
- There are numerous federal, national and local laws, regulations and standards. It is the responsibility of the owner and installer to observe these laws, regulations and standards (e.g. fire regulations and health and safety standards).
- Convotherm combi steamers are built to comply with the applicable standards for manufacturers.

### ACCESSORIES

(For more detailed information, please refer to the Accessories brochure.)

#### Stacking kit

Combinations allowed	6.20 on 6.20
	6.20 on 10.20

**If combining two gas units**

Select the "stacking kit for Convotherm 4 gas units"

**If combining one electrical unit and one gas unit in a stacking kit**

Select the "stacking kit for Convotherm 4 electrical units" if:

Bottom combi steamer	EB/ES
Top combi steamer	GB/GS

Select the "stacking kit for Convotherm 4 gas units" if:

Bottom combi steamer	GB/GS
Top combi steamer	EB/ES

#### Equipment stand

Standard support surface height	26.38"
---------------------------------	--------

9758235\_04 ENG\_USA 05/15. © 2015 Manitowoc. Please note that the product is being continuously improved and that, as a result, these specifications are subject to change without notice.

## **Baker Butler Elementary School Specifications**

**Provide a double deck combi oven consisting of (2) Each Gas, 6 pan, boiler based combi ovens – Basis of design - Cleveland Convotherm Model C4eT-6.20GB with the following features and scope of work:**

1. Disappearing door features which enables oven door to be slid back beside the oven. This allows the door to be out of the way when loading and unloading the oven for safety, labor savings, efficiency, and convenience.
2. Hands free fully automatic cleaning system with Eco, regular, and express modes. Cleaning chemicals must be in liquid form, and include a cleaner (Convoclean) and a neutralizer (Convocare). No manual handling of sprays or pucks will be allowed for safety and labor saving reasons. Automatic cleaning system will also go into a forced rinse for three minutes if the cleaning cycle is interrupted for any reason such as power outage. This will insure that no cleaning chemicals are ever allowed to remain in the cooking cavity. System to also have single-dose dispensing option.
3. Advanced Closed System +.
4. Crisp and Tasty demisting feature with five moisture removal settings that can be programmed into recipes.
5. Easy Touch controls with 9" full screen, 399 cooking profiles with up to 20 steps for each recipe, Press and Go quick select buttons, and tray timer - oven load management for different products at the same time.
6. USB port for easy downloading or uploading of recipes.
7. Capacity of (6) 18" x 26" sheet pans or (12) 12" x 20" x 2-1/2" deep full size steam table pans.
8. Retractable hand shower for spraying and cleaning oven compartment.
9. Antibacterial door handle which contains silver ions to stop the growth of microorganisms.
10. BakePro- five levels of traditional baking.
11. HumidityPro – five levels of humidity settings,
12. Auto reversing fan for even cooking with five speeds.
13. Vented double glass door with hinged inner glass that snaps out for easy cleaning.
14. Multi- point core temperature probe that uses the lowest reading to control the cooking process.
15. Two each Optipure Model QT1+CR filter systems
16. (12) wire shelves.

17. (12) CWB-10 wire frying baskets - 12" x 20".
18. Provide stacking kit with 13.8" base, model 3431606 which is compatible with chemical drawer
19. Provide model 3471200 chemical drawer
20. Provide (2) each 11000115805 Installation Kits (one per combi deck)
21. Provide (2) each gas quick disconnect hoses
22. Three year parts and labor warranty.
23. Natural gas

Vendor to remove existing double deck convection ovens and take to loading dock. Vendor to receive, deliver, uncrate and install new double deck combi and filter. Vendor to provide all final electrical, gas, water and drain connections.

# Combi steamer

Project \_\_\_\_\_  
 Item \_\_\_\_\_  
 Quantity \_\_\_\_\_  
 FCSI section \_\_\_\_\_  
 Approval \_\_\_\_\_  
 Date \_\_\_\_\_

C4eT 6.20 GB

## Model

Convotherm 4 easyTouch

- easyTouch
- 7 slide rails
- Gas
- Boiler
- Right-hinged door



## Key features

- ACS+ operating modes: Steam, combi-steam, hot air
- ACS+ extra functions:
  - Crisp&Tasty - 5 moisture-removal settings
  - BakePro - 5 levels of traditional baking
  - HumidityPro - 5 humidity settings
  - Controllable fan - 5 speed settings
- easyTouch 9" full-touch screen
- ConvoClean+ fully automatic cleaning system with eco, regular and express modes - with optional single-dose dispensing
- Ethernet interface (LAN)
- HygienicCare
- USB port integrated in the control panel
- TriColor indicator ring - indicates the current operating status
- Steam generated by high-performance boiler outside the cooking chamber
- Right-hinged door

## Standard features

- ACS+ (Advanced Closed System +) operating modes:
  - Steam (86-266°F) with guaranteed steam saturation
  - Combi-steam (86-482°F) with automatic humidity adjustment
  - Hot air (86-482°F) with optimized heat transfer
- HygienicCare - food safety provided by antibacterial surfaces:
  - easyTouch control panel
  - Door handle and recoil hand shower
- easyTouch user interface:
  - 9" full-touch screen
  - Press&Go - automatic cooking with quick-select buttons
  - TrayTimer - oven-load management for different products at the same time
  - Regenerate+ - flexible multi-mode retherm function
  - ecoCooking - energy-save function
  - Low-temperature cooking / Delta-T cooking
  - Cook&Hold - cook and hold in one process
  - 399 cooking profiles each containing up to 20 steps
  - On-screen help with topic-based video function
  - Start-time preset
- Multi-point core temperature probe
- Door handle with safety latch and slam function
- Data storage for HACCP and pasteurization figures
- Preheat and Cool down function

## Options

- Disappearing door – more space and added safety (see page 2)
- ConvoGrill with grease management function (upon request)
- ConvoSmoke - built in food-smoking
- Available in various voltages
- Sous-vide probe, external connection
- Core temperature probe, external connection

## Accessories

- ConvoLink HACCP and cooking-profile management PC software
- Signal tower - indicates the operating status from a distance
- Banquet system (optionally as a package or individually): Plate rack, mobile shelf rack, transport trolley, thermal cover
- Equipment stands in various sizes and designs
- Racks for cooking and baking
- Stacking kits
- Cleaning products for the fully automatic ConvoClean+ cleaning system and the semi-automatic cleaning system



**Front view**

(disappearing door optional)

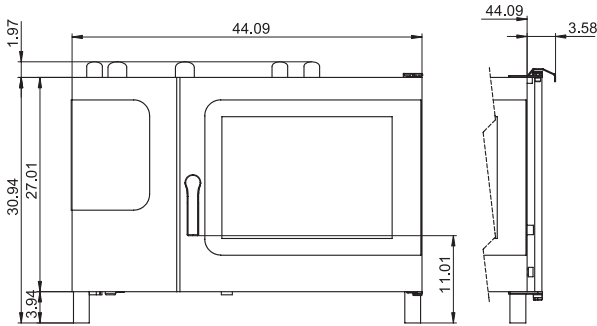

**Connection positions**

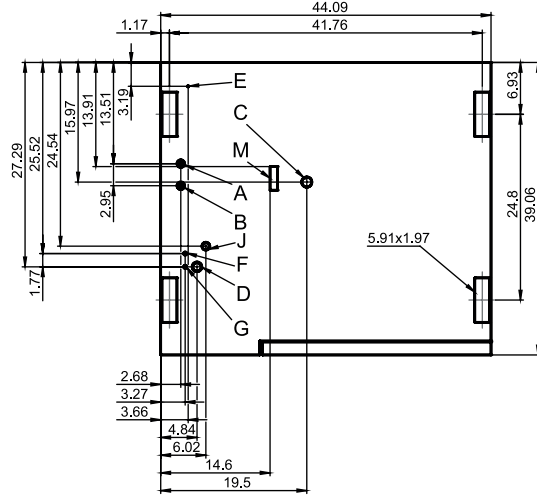

**View from above with wall clearances**

(disappearing door optional)

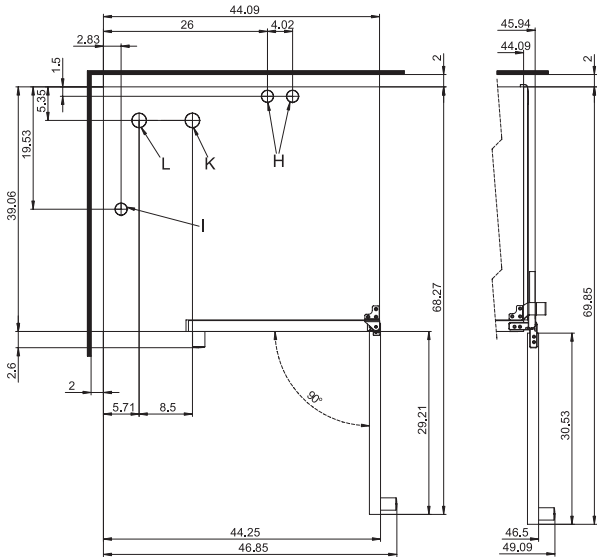

- A** Water connections (for boiler)
- B** Water connections (for cleaning, recoil hand shower)
- C** Drain connection (2" I. D.)
- D** Electrical connection
- E** Electrical ground
- F** Rinse-aid connection
- G** Cleaning-agent connection
- H** Air vent (2" I. D.)
- I** Ventilation port
- J** Gas connection
- K** Exhaust outlet (cooking compartment heating element)
- M** Safety overflow 3.2" x 1"

**Installation requirements**

Max. absolute appliance inclination during operation\*      max. 2° (3.4%)

\* Adjustable appliance feet as standard.

**Dimensions and weights**

**Dimensions including packaging**

Width x Height x Depth      53" x 39.8" x 44.9"

**Weight**

Net weight without options\* / accessories      437 lbs

Packaging weight      66 lbs

**Safety clearances\*\***

Rear	2"
Right (right-hinged door)	2"
Right (disappearing door pushed back)	5"
Left (18" clearance recommended for service)	2"
Top***	39"

\* Max. weight of options: 42 lbs.

\*\* Minimum clearance from heat sources: 20".

\*\*\* Depends on the type of exhaust system and the ceiling's characteristics.

### Loading capacity

**Max. number of food containers**

[Unit has 7 slide rails; rail spacing 2.68" max.]

Steam table pans (12"x20"x1")	12
Steam table pans (12"x20"x2.5")	12
Wire shelves, full size (20"x26")	6
Sheet pans, full size (18"x26")*	6
Sheet pans, half size (12"x20")*	12
Frying baskets, half size (12"x20")	12
Plates (optional plate rack)	27

**Max. loading weight**

Per combi steamer	132 lbs
Per shelf level	33 lbs

\* Wire shelves required.

### Electrical supply

**120V 1PH 60Hz \***

Rated power consumption	0.6 kW
Rated current	7.5 A
Power supply wire gauge	14 AWG
Conductor insulation rating	194°F / 90°C

\* Prepared for connection to an energy optimizing system.

### Water connections

**Water supply**

Water supply	Two 3/4" I. D. GHT-M (garden hose adapter). The appliance is designed for a permanent hookup to the water supply that uses a connecting hose with a minimum diameter of 1/2"
Flow pressure	22 - 87 PSI / 1.5 - 6 bar

**Drain**

Drain version	Permanent hookup (recommended) or funnel waste trap
Type	2" I. D. (comes elbow-shaped as standard)
Slope for drainpipe	min. 3.5% (2°)

### Water quality

**Water connection A\* for boiler, Water connection B\* for cleaning, recoil hand shower**

General requirements	Drinking water, typically untreated water
TDS	70 - 360 ppm
Hardness	70 - 360 ppm (4 - 21 gpg)
pH value	6.5 - 8.5
Cl <sup>-</sup> (chloride)	max. 60 ppm
Cl <sub>2</sub> (free chlorine)	max. 0.2 ppm
SO <sub>4</sub> <sup>2-</sup> (sulfate)	max. 150 ppm
Fe (iron)	max. 0.1 ppm
SiO <sub>2</sub> (silica)	max. 13 ppm
NH <sub>2</sub> Cl (monochloramine)	max. 0.4 ppm
Temperature	max. 104°F / max. 40°C

\* See connection positions diagram, p. 2.

NOTICE: The owner/operator/purchaser must ensure that the water quality requirements are met. Otherwise the original equipment warranty is void.

### Emissions

**Heat emission**

Latent	3400 BTU/h
Sensitive	3900 BTU/h

<b>Drain temperature</b>	max. 140°F / 60°C
--------------------------	-------------------

<b>Decibel rating</b>	max. 70 dBA
-----------------------	-------------

### Water consumption

**Water connections A, B**

Average consumption for cooking**	1.90 gph
Required flow rate	3.96 gpm

\*\* Incl. water required for cooling the wastewater.

NOTICE: See connection positions diagram, p. 2.

### Gas specifications

Type of gas	Natural gas, propane
Gas connection	1/2" NPT

**Flow pressure**

Natural gas	5.5 - 14" WC
Propane	11 - 14" WC

**Heat output** For Natural gas, propane

Convection burner	68200 BTU/h
Boiler burner	61400 BTU/h

**Please note:**

- Please refer to the Installation manual for further technical data and for instructions on installation and setup.
- Convotherm reserves the right of design improvement or modification, as warranted.
- There are numerous federal, national and local laws, regulations and standards. It is the responsibility of the owner and installer to observe these laws, regulations and standards (e.g. fire regulations and health and safety standards).
- Convotherm combi steamers are built to comply with the applicable standards for manufacturers.

### ACCESSORIES

(For more detailed information, please refer to the Accessories brochure.)

#### Stacking kit

Combinations allowed	6.20 on 6.20
	6.20 on 10.20

**If combining two gas units**

Select the "stacking kit for Convotherm 4 gas units"

**If combining one electrical unit and one gas unit in a stacking kit**

Select the "stacking kit for Convotherm 4 electrical units" if:

Bottom combi steamer	EB/ES
Top combi steamer	GB/GS

Select the "stacking kit for Convotherm 4 gas units" if:

Bottom combi steamer	GB/GS
Top combi steamer	EB/ES

#### Equipment stand

Standard support surface height	26.38"
---------------------------------	--------

9758235\_04 ENG\_USA 05/15. © 2015 Manitowoc. Please note that the product is being continuously improved and that, as a result, these specifications are subject to change without notice.

## **Brownsville Elementary School Specifications**

**Provide a double deck combi oven consisting of (2) Each Electric, 6 pan, boiler based combi ovens - Basis of design - Cleveland Convotherm Model C4eT-6.20EB with the following features and scope of work:**

1. Disappearing door features which enables oven door to be slid back beside the oven. This allows the door to be out of the way when loading and unloading the oven for safety, labor savings, efficiency, and convenience.
2. Hands free fully automatic cleaning system with Eco, regular, and express modes. Cleaning chemicals must be in liquid form, and include a cleaner (Convoclean) and a neutralizer (Convocare). No manual handling of sprays or pucks will be allowed for safety and labor saving reasons. Automatic cleaning system will also go into a forced rinse for three minutes if the cleaning cycle is interrupted for any reason such as power outage. This will insure that no cleaning chemicals are ever allowed to remain in the cooking cavity. System to also have single-dose dispensing option.
3. Advanced Closed System +.
4. Crisp and Tasty demisting feature with five moisture removal settings that can be programmed into recipes.
5. Easy Touch controls with 9" full screen, 399 cooking profiles with up to 20 steps for each recipe, Press and Go quick select buttons, and tray timer - oven load management for different products at the same time.
6. USB port for easy downloading or uploading of recipes.
7. Capacity of (6) 18" x 26" sheet pans or (12) 12" x 20" x 2-1/2" deep full size steam table pans.
8. Retractable hand shower for spraying and cleaning oven compartment.
9. Antibacterial door handle which contains silver ions to stop the growth of microorganisms.
10. BakePro- five levels of traditional baking.
11. HumidityPro – five levels of humidity settings,
12. Auto reversing fan for even cooking with five speeds.
13. Vented double glass door with hinged inner glass that snaps out for easy cleaning.
14. Multi- point core temperature probe that uses the lowest reading to control the cooking process.
15. Two each Optipure Model QT1+CR filter systems
16. (12) wire shelves.

17. (12) CWB-10 wire frying baskets - 12" x 20".
18. Provide stacking kit with 13.8" base, model 3431606 which is compatible with chemical drawer
19. Provide model 3471200 chemical drawer
20. Provide (2) each 11000115806 Installation Kits (one per combi deck)
21. Three year parts and labor warranty.
22. 208 volts, 3 phase

Vendor to remove existing double deck convection ovens and take to place in the school requested. Vendor to receive, deliver, uncrate and install new double deck combi and filter. Vendor to provide all final electrical, water and drain connections.

# Combi steamer

Project \_\_\_\_\_  
 Item \_\_\_\_\_  
 Quantity \_\_\_\_\_  
 FCSI section \_\_\_\_\_  
 Approval \_\_\_\_\_  
 Date \_\_\_\_\_

## Model

Convotherm 4 easyTouch

- easyTouch
- 7 slide rails
- Electrical
- Boiler
- Right-hinged door



## Key features

- ACS+ operating modes: Steam, combi-steam, hot air
- ACS+ extra functions:
  - Crisp&Tasty - 5 moisture-removal settings
  - BakePro - 5 levels of traditional baking
  - HumidityPro - 5 humidity settings
  - Controllable fan - 5 speed settings
- easyTouch 9" full-touch screen
- ConvoClean+ fully automatic cleaning system with eco, regular and express modes - with optional single-dose dispensing
- Ethernet interface (LAN)
- HygienicCare
- USB port integrated in the control panel
- TriColor indicator ring - indicates the current operating status
- Steam generated by high-performance boiler outside the cooking chamber
- Right-hinged door
- KNLZ listed for ventless operation, local codes prevail as in NFPA 96-1994

## Standard features

- ACS+ (Advanced Closed System +) operating modes:
  - Steam (86-266°F) with guaranteed steam saturation
  - Combi-steam (86-482°F) with automatic humidity adjustment
  - Hot air (86-482°F) with optimized heat transfer
- HygienicCare - food safety provided by antibacterial surfaces:
  - easyTouch control panel
  - Door handle and recoil hand shower
- easyTouch user interface:
  - 9" full-touch screen
  - Press&Go - automatic cooking with quick-select buttons
  - TrayTimer - oven-load management for different products at the same time
  - Regenerate+ - flexible multi-mode retherm function
  - ecoCooking - energy-save function
  - Low-temperature cooking / Delta-T cooking
  - Cook&Hold - cook and hold in one process
  - 399 cooking profiles each containing up to 20 steps
  - On-screen help with topic-based video function
  - Start-time preset
- Multi-point core temperature probe
- Door handle with safety latch and slam function
- Data storage for HACCP and pasteurization figures
- Preheat and Cool down function

## Options

- Steam and vapor removal – built-in condenser (upon request)
- Disappearing door – more space and added safety (see page 2)
- ConvoGrill with grease management function (upon request)
- ConvoSmoke - built in food-smoking
- Marine version (see separate data sheet)
- Available in various voltages
- Sous-vide probe, external connection
- Core temperature probe, external connection

## Accessories

- ConvoLink HACCP and cooking-profile management PC software
- Signal tower - indicates the operating status from a distance
- Banquet system (optionally as a package or individually): Plate rack, mobile shelf rack, transport trolley, thermal cover
- Equipment stands in various sizes and designs
- Racks for cooking and baking
- Stacking kits
- Cleaning products for the fully automatic ConvoClean+ cleaning system and the semi-automatic cleaning system

Commercial combination oven with integral systems for limiting the emissions of grease laden air  
 This product conforms to the ventless operation recommendations set forth by NFPA96 using EPA202 test method



Front view

(disappearing door optional)

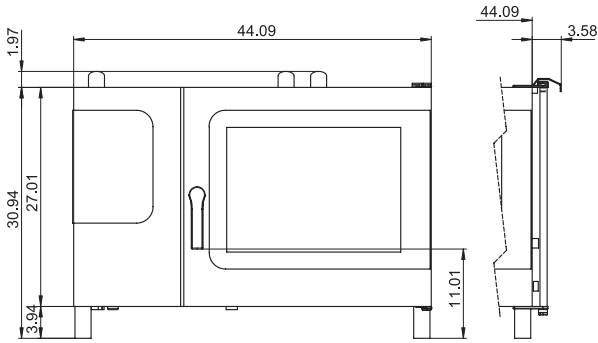

Connection positions

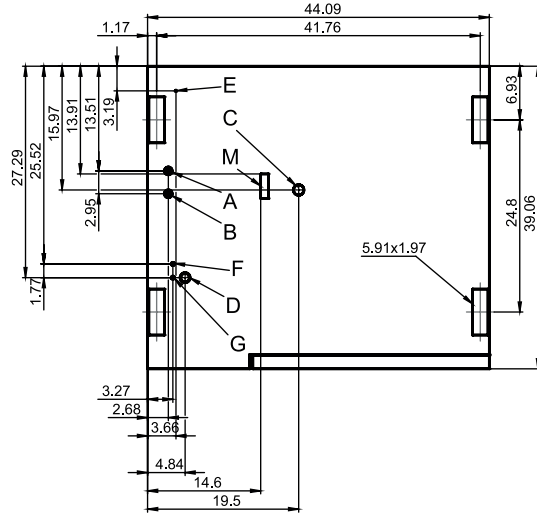

View from above with wall clearances

(disappearing door optional)

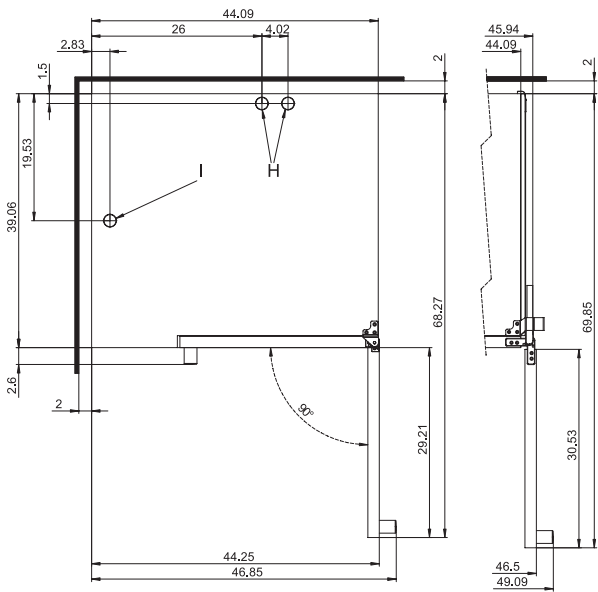

- A Water connections (for boiler)
- B Water connections (for cleaning, recoil hand shower)
- C Drain connection (2" I. D.)
- D Electrical connection
- E Electrical ground
- F Rinse-aid connection
- G Cleaning-agent connection
- H Air vent (2" I. D.)
- I Ventilation port
- M Safety overflow 3.2" x 1"

Dimensions and weights

Dimensions including packaging

Width x Height x Depth 53" x 39.8" x 44.9"

Weight

Net weight without options\* / accessories 392 lbs  
 Packaging weight 66 lbs

Safety clearances\*\*

Rear 2"  
 Right (right-hinged door) 2"  
 Right (disappearing door pushed back) 5"  
 Left (18" clearance recommended for service) 2"  
 Top\*\*\* 20"

\* Max. weight of options: 42 lbs.

\*\* Minimum clearance from heat sources: 20".

\*\*\* Depends on the type of exhaust system and the ceiling's characteristics.

Installation requirements

Max. absolute appliance inclination during operation\* max. 2° (3.4%)

\* Adjustable appliance feet as standard.

9758233\_04 ENG\_USA 05/15. © 2015 Manitowoc. Please note that the product is being continuously improved and that, as a result, these specifications are subject to change without notice.

## Loading capacity

### Max. number of food containers

[Unit has 7 slide rails; rail spacing 2.68" max.]

Steam table pans (12"x20"x1")	12
Steam table pans (12"x20"x2.5")	12
Wire shelves, full size (20"x26")	6
Sheet pans, full size (18"x26")*	6
Sheet pans, half size (12"x20")*	12
Frying baskets, half size (12"x20")	12
Plates (optional plate rack)	27

### Max. loading weight

Per combi steamer	132 lbs
Per shelf level	33 lbs

\* Wire shelves required.

## Electrical supply

### 208V 3PH 60Hz / 240V 3PH 60Hz \*

Rated power consumption	15.9 / 21.0 kW
Rated current	44.1 / 50.6 A
Power supply wire gauge	6 AWG
Conductor insulation rating	194°F / 90°C

### 440V 3PH 60Hz / 480V 3PH 60Hz \*

Rated power consumption	16.3 / 19.3 kW
Rated current	21.4 / 23.3 A
Power supply wire gauge	8 AWG
Conductor insulation rating	194°F / 90°C

When using the ConvoSmoke option, the only available voltage options are:

### 208V 3PH 60Hz \*

Rated power consumption	15.9 kW
Rated current	44.1 A
Power supply wire gauge	6 AWG
Conductor insulation rating	194°F / 90°C

### 240V 3PH 60Hz \*

Rated power consumption	21.0 kW
Rated current	50.6 A
Power supply wire gauge	6 AWG
Conductor insulation rating	194°F / 90°C

\* Prepared for connection to an energy optimizing system.

## Water connections

### Water supply

Water supply	Two 3/4" I. D. GHT-M (garden hose adapter). The appliance is designed for a permanent hookup to the water supply that uses a connecting hose with a minimum diameter of 1/2"
Flow pressure	22 - 87 PSI / 1.5 - 6 bar

### Drain

Drain version	Permanent hookup (recommended) or funnel waste trap
Type	2" I. D. (comes elbow-shaped as standard)
Slope for drainpipe	min. 3.5% (2°)

## Water quality

### Water connection A\* for boiler, Water connection B\* for cleaning, recoil hand shower

General requirements	Drinking water, typically untreated water
TDS	70 - 360 ppm
Hardness	70 - 360 ppm (4 - 21 gpg)
pH value	6.5 - 8.5
Cl <sup>-</sup> (chloride)	max. 60 ppm
Cl <sub>2</sub> (free chlorine)	max. 0.2 ppm
SO <sub>4</sub> <sup>2-</sup> (sulfate)	max. 150 ppm
Fe (iron)	max. 0.1 ppm
SiO <sub>2</sub> (silica)	max. 13 ppm
NH <sub>2</sub> Cl (monochloramine)	max. 0.4 ppm
Temperature	max. 104°F / max. 40°C

\* See connection positions diagram, p. 2.

NOTICE: The owner/operator/purchaser must ensure that the water quality requirements are met. Otherwise the original equipment warranty is void.

Emissions

Heat emission

Latent	3400 BTU/h
Sensitive	4300 BTU/h

Drain temperature	max. 140°F / 60°C
-------------------	-------------------

Decibel rating	max. 70 dBA
----------------	-------------

Water consumption

Water connections A, B

Average consumption for cooking**	1.90 gph
Required flow rate	3.96 gpm

\*\* Incl. water required for cooling the wastewater.

NOTICE: See connection positions diagram, p. 2.

Please note:

- Please refer to the Installation manual for further technical data and for instructions on installation and setup.
- Convotherm reserves the right of design improvement or modification, as warranted.
- There are numerous federal, national and local laws, regulations and standards. It is the responsibility of the owner and installer to observe these laws, regulations and standards (e.g. fire regulations and health and safety standards).
- Convotherm combi steamers are built to comply with the applicable standards for manufacturers.

ACCESSORIES

(For more detailed information, please refer to the Accessories brochure.)

Stacking kit

Combinations allowed	6.20 on 6.20
	6.20 on 10.20

If combining two electrical units

Select the "stacking kit for Convotherm 4 electrical units"

If combining one electrical unit and one gas unit in a stacking kit

Select the "stacking kit for Convotherm 4 electrical units" if:

Bottom combi steamer	EB/ES
Top combi steamer	GB/GS

Select the "stacking kit for Convotherm 4 gas units" if:

Bottom combi steamer	GB/GS
Top combi steamer	EB/ES

Equipment stand

Standard support surface height	26.38"
---------------------------------	--------

## **Burley Middle School Specifications**

**Provide One (1) Each Double Deck Gas Convection Oven,- Basis of design - Garland Model MCO-GS-20-S with the following features:**

1. Stainless steel front, sides, top and legs.
2. Safe door feature.
3. 13 rack position guides.
4. 6 racks per deck.
5. 24" high interior.
6. 60/40 door design with dependent doors.
7. Stainless steel doors with windows.
8. .6 H.P. two speed motors.
9. Master 200 solid state controls.
10. Porcelain oven cavity with coved corners.
11. Provide low profile casters
12. Natural gas
13. Three year parts and labor warranty.
14. Five year door warranty
15. Dormont 16100KIT48 gas connector kit

Vendor to remove old and take to loading dock or place in school where required, vendor to deliver new equipment, uncrate, set in place and make all gas and electric final connections and start up ovens.

# Master Gas Convection Oven 200 Solid State Control

Project \_\_\_\_\_  
Item \_\_\_\_\_  
Quantity \_\_\_\_\_  
CSI Section 11400  
Approved \_\_\_\_\_  
Date \_\_\_\_\_

## Models

- MCO-GS-10-S      • MCO-GD-10-S      • MCO-GS-10-ESS (Energy Star)
- MCO-GS-20-S      • MCO-GD-20-S      • MCO-GS-20-ESS (Energy Star)



Model MCO-GS-10-S  
Shown with optional casters

## Standard Features

- Master 200 Solid State Control with 150°F (66°C) to 500° (260°C) temperature range and electromechanical timer
- Direct spark with 100% safety shut off
- 2-speed fan control (high & low) with .6 HP fan motor
- Total of 60,000 BTU (17.6 kW) loading per oven cavity
- Natural or propane gas
- Stainless steel front, sides, top, and legs
- 60/40 dependent door design with double pane thermal window in both doors and interior lighting
- Full Length, stainless steel positive door closure
- Patented "Safety Door System"
- Porcelain enameled oven interior with coved corners
- 24" cooking cavity height w/6 chrome plated oven racks on 13-position rack guides
- Double deck models available, suffix -20-S
- Deep depth models available prefix MCO-GD
- Energy Star models available, suffix -ESS

## Warranty

- 2 year limited part & 1 year labor warranty (USA & Canada only)
- 2 year limited part & labor warranty (USA Kindergarten to grade 12 schools only)
- 5 year limited door warranty, excluding window (USA & Canada only)

## Options & Accessories

- 80,000 BTU (23.4kW) burner package (natural gas)
- Stainless steel solid door or doors (specify) – No Charge
- Extra oven racks
- Swivel casters, (4) w/front brakes
- 4 Low profile casters, w/front brakes (double ovens only)
- Stainless steel open base with rack guides and shelf
- Direct connect vent
- Back enclosure (stainless steel)
- 3/4" gas flex hose & quick disconnect
- 208 or 240 volt, single phase motor (please specify)
- Maximum security package available contact factory for details

## Specifications

- Garland Master Full-Size Standard Depth, prefix MCO-GS or Deep Depth, prefix MCO-GD, gas convection oven.
- 60,000 BTU (17.6 kW)/cavity, .6 HP fan motor with two speed fan control. Electronic/spark ignition. Natural or propane-gas. Master 200 solid state control with digital timer.
- Porcelain enameled oven interior with coved corners, Six (6) oven racks and 13-position rack guides.
- All model interiors are 29" (736mm) W by 24" (610mm) H, depth is 24" (610mm) for standard depth and 28" (711mm) for deep depth. Stainless steel front, sides, top, and legs. 60/40 dependent door design with double pane thermal window in both doors and interior lighting.
- Models with suffix -20-S are double deck units. Specify voltage if other than 115 volt, 60 Hz, 1 phase.
- Models with suffix -20-ESS are double deck units. Specify voltage if other than 115 volt, 60 Hz, 1 phase.
- UL, CUL Gas-Fired and NSF Listed.
- Energy Star approved (Standard depth model only)



# Master Gas Convection Oven 200 Solid State Control

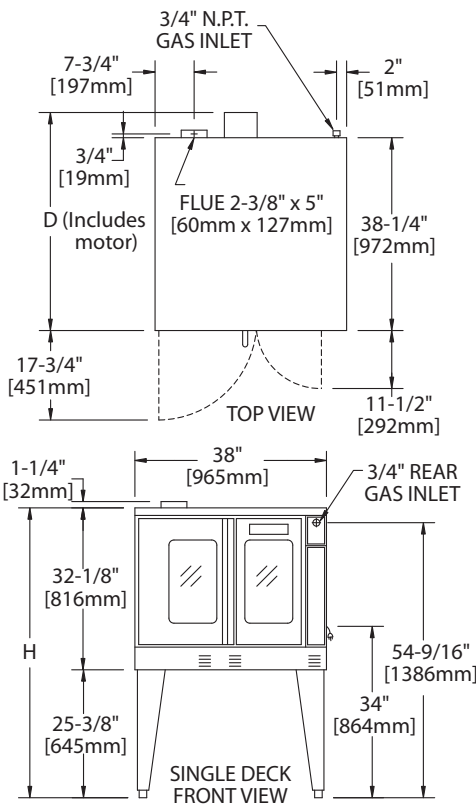

Gas Input Ratings shown here are for installations up to 2,000 ft. (610m) above sea level. Specify altitudes over 2,000 ft. Please specify gas type when ordering.

**INSTALLATION NOTE:**

**Combustible Wall Clearances:**  
 Sides: 1" (25mm) Back: 3" (76mm)

**\*Note:** Installations beside units with high heat sources it is recommended to leave 6" (152mm) on the right side of oven. Refer to the installation manual for more details.

**Combustible Wall Clearances:**  
 Crated: 47" (1194mm) Uncrated: 32 1/2" (826mm)

**Manifold Operating Pressure:**  
 Natural: 4.5" WC (11 mbar) Propane: 10" WC (25 mbar) Max 13.8" WC @ 70°F

**Note:** Data applies only to North America

**PLEASE NOTE:**

Standard electrical specifications include motor requirements (120V units) 115V, .6 HP, 2-speed motor; 1430 and 1670 rpm, (240V units) 200-240V, .6 HP, 2-speed motor; 1430 and 1670 rpm, 60 Hz. A 6 ft. line cord is provided for each 120V deck with a (NEMA#5-15P) plug.

SINGLE-DECK MODELS	INT. DIMENSIONS: In mm			EXT. DIMENSIONS: In mm			SHIP WT.	SHIP DIM.
	W	H	D	W	H*	D	lbs/kg	cubic Ft.
Standard Depth**	29 (736)	24 (610)	24 (610)	38 (965)	57-1/2 (1461)	41-1/4(1048)	515/230	64
Deep Depth	29 (736)	24 (610)	28 (711)	38 (965)	57-1/2 (1461)	44-1/2(1130)	545/245	64

DOUBLE-DECK MODELS	INT. DIMENSIONS: In mm			EXT. DIMENSIONS In mm			SHIP WT.	SHIP DIM.
	W	H	D	W	H*	D	2@lbs/kg	Cubic Ft.
Standard Depth**	29 (736)	24 (610)	24 (610)	38 (965)	70-1/2 (1791)	41-1/4(1048)	1030/465	128
Deep Depth	29 (736)	24 (610)	28 (711)	38 (965)	70-1/2 (1791)	44-1/2(1130)	1090/490	128

\*Height with or without standard casters. Height with low profile casters (double deck) is 68-1/2" (1740mm).

MODELS	INPUT RATINGS, NAT & PRO			ELECTRICAL SPECIFICATIONS	
	BTU/hr	kW Equiv.	Gas inlet	120V/1Ph.	240V/1Ph.
Single Deck	60,000	17.6	(1)@3/4" NPT	(1)@9.8A	(1)@5.2A
Double Deck	120,000	35.2	(1)@1" NPT	(2)@9.8A	(2)@5.2A

\*\* Energy Star Approved available on Standard depth models (MCO-GS-10-ESS, MCO-GS-20-ESS)

Welbilt reserves the right to make changes to the design or specifications without prior notice.

## **Greer Elementary School Specifications**

**Provide (1) one each – Basis of design - Cleveland Model 24CEA-10 with the following features:**

1. Two independent, fully insulated steam generators mounted in rear.
2. Both generators to each have two 8 KW Fire Bar heating elements.
3. 14 gauge stainless steel construction for doors, cooking cavities, and steam generators.
4. Electro-mechanical controls.
5. Reversible gaskets.
6. Two generator cleaning ports located on top of unit.
7. Provide (1) each QT11-CR Optipure filter
8. Three year parts and labor warranty
9. 480 volt, 3 phase, 32 K.W.

Vendor to remove existing steamer and take to loading dock. Vendor to receive, deliver, uncrate and install new steamer and filter. Vendor to provide all final electrical, water and drain connections.

# SteamCraft® Gemini™ 10

TWO COMPARTMENT FLOOR MODEL DESIGN PRESSURELESS CONVECTION STEAMER TWIN ELECTRIC STEAM GENERATORS, 16 KW EACH

Project \_\_\_\_\_  
 Item \_\_\_\_\_  
 Quantity \_\_\_\_\_  
 FCSI Section 11400 \_\_\_\_\_  
 Approved \_\_\_\_\_  
 Date \_\_\_\_\_

SteamCraft® Generator Style High Speed Convection Steamers

## Models

- 24-CEA-10



Shown with optional Electronic Timer

## Standard Features

- Cooking Capacity for up to ten 12" x 20" x 2 1/2" deep Cafeteria Pans, five each compartment.
- Innovative PowerPak Electric Steam Generator: Twin Vertical Atmospheric Electric Steam Generators operate independently. Two 8 KW Fire Bar Heating Elements per generator. Strong 14 Gauge Stainless Steel Construction. Large 5 gallon generator reservoir for each compartment for high speed steam cooking production. Two fully insulated rear mounted independent steam generators.
- Each steam-cooking compartment is independently operated and controlled by a separate stainless steel steam generator.
- Easy Access Generator Cleaning Port: Two Generator Cleaning Ports located on the outside, top of the unit.
- Instant Steam Stand By Mode: Hold generator at a steaming temperature. Allows unit to start cooking instantly.
- Durable 14 Gauge, Stainless Steel Construction: For compartment door, cavity and steam generator.
- Two 60 Minute Electro-Mechanical Timers and Switches for manual operation: Audible signal for cooking time completion. (MCS)
- Main Power On/Off Switch: Automatically fills generator with water, and then starts heating elements in generator.
- Exclusive Steam Cooking Distribution System: Exclusive Brass Steam Jets produce a high velocity convection steam without fans. Coved Corner design in cooking compartment distributes heat evenly, and is easy to clean. Creased top & bottom enhance drainage. Cold Water Condenser for each compartment maintains a dry steam. Fully Insulated cooking compartment for thermal efficiency. Removable Stainless Steel Slide Racks.
- Automatic Generator Drain: Contains a "Water Jet" Spray Rinse Drain Cleaning Cycle to keep drain clear.
- Exclusive Automatic Probe for Water Level Control: Separate from the generator for easy access, contains a high velocity rinse cycle to eliminate mineral build up.
- Exclusive "Cool to the Touch" Two-Piece Compartment Door Design: Free floating inner door with reversible gasket provides an air tight seal. Stainless Steel Slam/Latch Door Latch mechanism for reliability.
- Condensate Drip Trough: Provide under lower compartment door to collect condensate.
- Left Hand Door Hinging: Compartment Doors hinged on the left, controls on the right.
- NSF Certified 6" Stainless Steel Legs with adjustable flanged feet for a one inch level adjustment.
- Compartment Door Steam Shut Off Switch (SCS)

## Short Form Specifications

Shall be Two Compartments, Cleveland Convection Steamer series SteamCraft® Gemini™ 10, Model 24-CEA-10, Twin Electric Atmospheric Steam Generator, 32 KW input. Remote Probe Type Water Level Controls. Steam Generator with Automatic Water Fill on start up. Automatic Generator Blowdown, Two each 16.5 KW Fire Bar Heating Elements. Choice of Compartment Controls, Manual By Pass Operation Mode, Exclusive Cold Water Condenser design, Type 430 Stainless Steel exterior and cooking compartments.

## Options & Accessories

- Right hand Door Hinging, Controls on the Right (DHR)
- Electronic Timer with Compensating Load Feature (ETC)
- 10" Stainless Steel Legs (LF10)
- Dissolve® Descale Solution, 6 one gallon container w/quart markings (106174)
- Cafeteria Pans in depths of 1", 2 1/2" and 4"
- Low Wattage Option, 8 KW each compartment (LWO)
- Water Filters

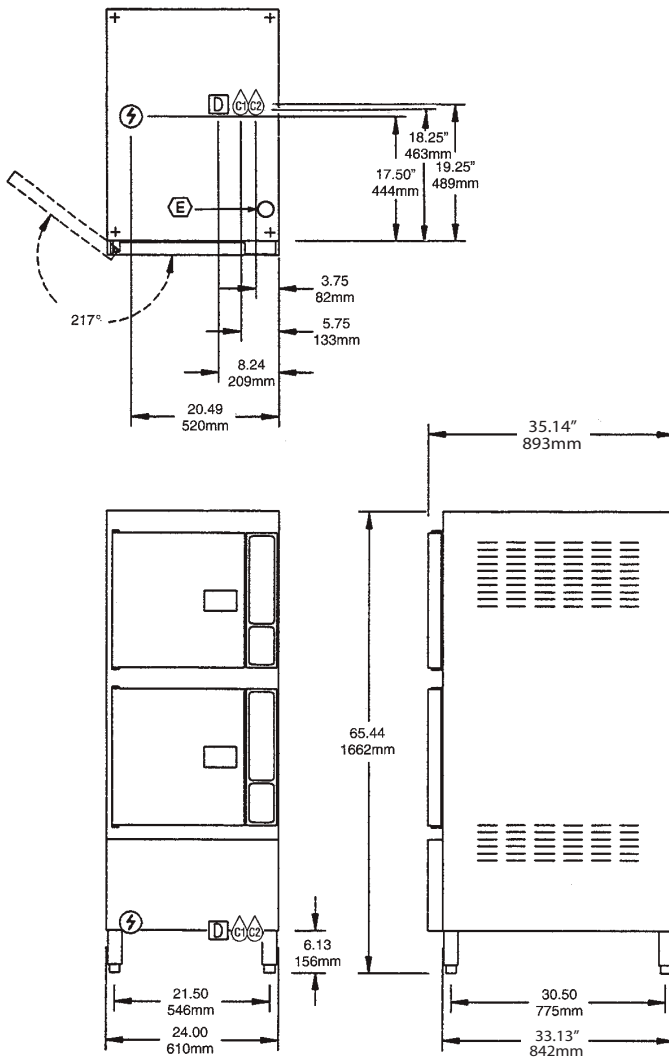

**COMPARTMENT HAS CAPACITY FOR:**

- Five, 12" x 20" x 2 1/2" deep Cafeteria Pans

**WATER QUALITY REQUIREMENTS (Boilers, Generators)**

TTDS:	50-250 ppm
Hardness:	50 - 200 mm (3 - 12 gpg)
pH value:	7.0 - 8.5
CL (Chloride):	max 50 ppm
Cl <sub>2</sub> (free chlorine):	max 0.1 ppm
SiO <sub>2</sub> (silica):	max 13 ppm
NH <sub>2</sub> Cl:	max 0.1 ppm (mono-chloramine)
Total Alkalinity:	50 - 100 ppm
Water Pressure	35 - 80 PSI
Temperature:	max 104°F

ELECTRIC ⚡		COLD WATER ⒸⒹ	DRAINAGE Ⓓ	CLEARANCE																																																														
<b>STANDARD ELECTRIC</b> <table border="1"> <tr><th>Volts</th><th>Watts</th><th>Ph</th><th>Amps</th><th>Wire</th></tr> <tr><td>208</td><td>32,600</td><td>3</td><td>91.7</td><td>3</td></tr> <tr><td>220</td><td>27,393</td><td>3</td><td>72.9</td><td>3</td></tr> <tr><td>240</td><td>32,600</td><td>3</td><td>79.5</td><td>3</td></tr> <tr><td>440</td><td>27,393</td><td>3</td><td>36.4</td><td>3</td></tr> <tr><td>480</td><td>32,600</td><td>3</td><td>39.8</td><td>3</td></tr> </table>		Volts	Watts	Ph	Amps	Wire	208	32,600	3	91.7	3	220	27,393	3	72.9	3	240	32,600	3	79.5	3	440	27,393	3	36.4	3	480	32,600	3	39.8	3	<b>LOW WATTAGE OPTION</b> <table border="1"> <tr><th>Volts</th><th>Watts</th><th>Ph</th><th>Amps</th><th>Wire</th></tr> <tr><td>208</td><td>16,600</td><td>3</td><td>47.3</td><td>3</td></tr> <tr><td>220</td><td>13,948</td><td>3</td><td>37.6</td><td>3</td></tr> <tr><td>240</td><td>16,600</td><td>3</td><td>41.0</td><td>3</td></tr> <tr><td>440</td><td>13,948</td><td>3</td><td>18.8</td><td>3</td></tr> <tr><td>480</td><td>16,600</td><td>3</td><td>20.5</td><td>3</td></tr> </table>		Volts	Watts	Ph	Amps	Wire	208	16,600	3	47.3	3	220	13,948	3	37.6	3	240	16,600	3	41.0	3	440	13,948	3	18.8	3	480	16,600	3	20.5	3	35 psi minimum 60 psi maximum Ⓒ 1/2" Dia. NPT for Generator (for water treatment connection) Ⓓ 1/2" Dia. NPT for Condenser	1 1/2" dia. Do not connect other units to this drain Drain must not be located beneath the steamer itself. Preferred floor drain location should be a minimum distance (from the unit) of at least 12" from the left side, 12" from the right side, 6" from the front and 6" from the rear Do not use PVC pipe	Right - 3", Left - 3", Rear - 3" (12" on control side if adjoining wall or equipment is over 30" high for service access) <b>Contact factory for variances to clearances.</b>
Volts	Watts	Ph	Amps	Wire																																																														
208	32,600	3	91.7	3																																																														
220	27,393	3	72.9	3																																																														
240	32,600	3	79.5	3																																																														
440	27,393	3	36.4	3																																																														
480	32,600	3	39.8	3																																																														
Volts	Watts	Ph	Amps	Wire																																																														
208	16,600	3	47.3	3																																																														
220	13,948	3	37.6	3																																																														
240	16,600	3	41.0	3																																																														
440	13,948	3	18.8	3																																																														
480	16,600	3	20.5	3																																																														

TOTAL CAPACITY (2 Compartments)	UTILITY CONNECTIONS
10 — 12" x 20" x 2 1/2" Cafeteria Pans or 20 — 12" x 20" x 1" Cafeteria Pans or 6 — 12" x 20" x 4" Cafeteria Pans	Ⓐ Electrical Supply Ⓑ Cold Water Supply for Condenser 3/8" Dia. NPT Ⓒ Cold Water Supply for Generator and Water Injection. 3/8" Dia. NPT (for water treatment conn.) Unit comes with a 50 Mesh Water Strainer (installation required) Ⓓ Drain: 1.50" Dia. Ⓔ Inlet for Generator Deliming Solution

**NOTES:**

Cleveland Range reserves right of design improvement or modification, as warranted.  
 Many regional, state and local codes exist and it is the responsibility of the owner and installer to comply with the codes.  
 Cleveland Range equipment is built to comply with applicable standards for manufacturers. Included among those approval agencies are U.L./NSF#4 and CSA (AGA, CGA).

(NOT TO SCALE)

## **Journey Middle School Specifications**

**Provide (1) one each – Basis of design - Cleveland Model 24CEA-10 with the following features:**

1. Two independent, fully insulated steam generators mounted in rear.
2. Both generators to each have two 8 KW Fire Bar heating elements.
3. 14 gauge stainless steel construction for doors, cooking cavities, and steam generators.
4. Electro-mechanical controls.
5. Reversible gaskets.
6. Two generator cleaning ports located on top of unit.
7. Provide (1) each QTI1-CR Optipure filter
8. Three year parts and labor warranty
9. 480 volt, 3 phase, 32 K.W.

Vendor to remove existing steamer and take to loading dock. Vendor to receive, deliver, uncrate and install new steamer and filter. Vendor to provide all final electrical, water and drain connections.

# SteamCraft® Gemini™ 10

TWO COMPARTMENT FLOOR MODEL DESIGN PRESSURELESS CONVECTION STEAMER TWIN ELECTRIC STEAM GENERATORS, 16 KW EACH

Project \_\_\_\_\_  
 Item \_\_\_\_\_  
 Quantity \_\_\_\_\_  
 FCSI Section 11400 \_\_\_\_\_  
 Approved \_\_\_\_\_  
 Date \_\_\_\_\_

SteamCraft® Generator Style High Speed Convection Steamers

## Models

- 24-CEA-10



Shown with optional Electronic Timer

## Standard Features

- Cooking Capacity for up to ten 12" x 20" x 2 1/2" deep Cafeteria Pans, five each compartment.
- Innovative PowerPak Electric Steam Generator: Twin Vertical Atmospheric Electric Steam Generators operate independently. Two 8 KW Fire Bar Heating Elements per generator. Strong 14 Gauge Stainless Steel Construction. Large 5 gallon generator reservoir for each compartment for high speed steam cooking production. Two fully insulated rear mounted independent steam generators.
- Each steam-cooking compartment is independently operated and controlled by a separate stainless steel steam generator.
- Easy Access Generator Cleaning Port: Two Generator Cleaning Ports located on the outside, top of the unit.
- Instant Steam Stand By Mode: Hold generator at a steaming temperature. Allows unit to start cooking instantly.
- Durable 14 Gauge, Stainless Steel Construction: For compartment door, cavity and steam generator.
- Two 60 Minute Electro-Mechanical Timers and Switches for manual operation: Audible signal for cooking time completion. (MCS)
- Main Power On/Off Switch: Automatically fills generator with water, and then starts heating elements in generator.
- Exclusive Steam Cooking Distribution System: Exclusive Brass Steam Jets produce a high velocity convection steam without fans. Coved Corner design in cooking compartment distributes heat evenly, and is easy to clean. Creased top & bottom enhance drainage. Cold Water Condenser for each compartment maintains a dry steam. Fully Insulated cooking compartment for thermal efficiency. Removable Stainless Steel Slide Racks.
- Automatic Generator Drain: Contains a "Water Jet" Spray Rinse Drain Cleaning Cycle to keep drain clear.
- Exclusive Automatic Probe for Water Level Control: Separate from the generator for easy access, contains a high velocity rinse cycle to eliminate mineral build up.
- Exclusive "Cool to the Touch" Two-Piece Compartment Door Design: Free floating inner door with reversible gasket provides an air tight seal. Stainless Steel Slam/Latch Door Latch mechanism for reliability.
- Condensate Drip Trough: Provide under lower compartment door to collect condensate.
- Left Hand Door Hinging: Compartment Doors hinged on the left, controls on the right.
- NSF Certified 6" Stainless Steel Legs with adjustable flanged feet for a one inch level adjustment.
- Compartment Door Steam Shut Off Switch (SCS)

## Short Form Specifications

Shall be Two Compartments, Cleveland Convection Steamer series SteamCraft® Gemini™ 10, Model 24-CEA-10, Twin Electric Atmospheric Steam Generator, 32 KW input. Remote Probe Type Water Level Controls. Steam Generator with Automatic Water Fill on start up. Automatic Generator Blowdown, Two each 16.5 KW Fire Bar Heating Elements. Choice of Compartment Controls, Manual By Pass Operation Mode, Exclusive Cold Water Condenser design, Type 430 Stainless Steel exterior and cooking compartments.

## Options & Accessories

- Right hand Door Hinging, Controls on the Right (DHR)
- Electronic Timer with Compensating Load Feature (ETC)
- 10" Stainless Steel Legs (LF10)
- Dissolve® Descale Solution, 6 one gallon container w/quart markings (106174)
- Cafeteria Pans in depths of 1", 2 1/2" and 4"
- Low Wattage Option, 8 KW each compartment (LWO)
- Water Filters

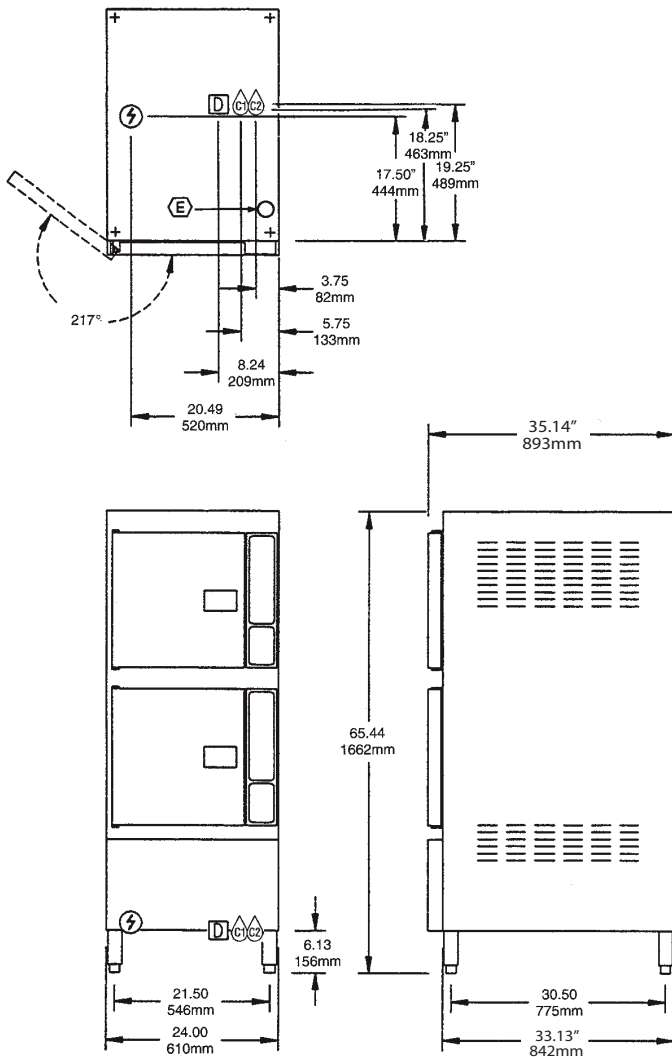
**COMPARTMENT HAS CAPACITY FOR:**

- Five, 12" x 20" x 2 1/2" deep Cafeteria Pans

**WATER QUALITY REQUIREMENTS (Boilers, Generators)**

TTDS:	50-250 ppm
Hardness:	50 - 200 mm (3 - 12 gpg)
pH value:	7.0 - 8.5
CL (Chloride):	max 50 ppm
Cl <sub>2</sub> (free chlorine):	max 0.1 ppm
SiO <sub>2</sub> (silica):	max 13 ppm
NH <sub>2</sub> Cl:	max 0.1 ppm (mono-chloramine)
Total Alkalinity:	50 - 100 ppm
Water Pressure	35 - 80 PSI
Temperature:	max 104°F

ELECTRIC ⚡		COLD WATER ⓄⓄ	DRAINAGE Ⓛ	CLEARANCE																																																														
<b>STANDARD ELECTRIC</b> <table border="1"> <thead> <tr> <th>Volts</th> <th>Watts</th> <th>Ph</th> <th>Amps</th> <th>Wire</th> </tr> </thead> <tbody> <tr> <td>208</td> <td>32,600</td> <td>3</td> <td>91.7</td> <td>3</td> </tr> <tr> <td>220</td> <td>27,393</td> <td>3</td> <td>72.9</td> <td>3</td> </tr> <tr> <td>240</td> <td>32,600</td> <td>3</td> <td>79.5</td> <td>3</td> </tr> <tr> <td>440</td> <td>27,393</td> <td>3</td> <td>36.4</td> <td>3</td> </tr> <tr> <td>480</td> <td>32,600</td> <td>3</td> <td>39.8</td> <td>3</td> </tr> </tbody> </table>		Volts	Watts	Ph	Amps	Wire	208	32,600	3	91.7	3	220	27,393	3	72.9	3	240	32,600	3	79.5	3	440	27,393	3	36.4	3	480	32,600	3	39.8	3	<b>LOW WATTAGE OPTION</b> <table border="1"> <thead> <tr> <th>Volts</th> <th>Watts</th> <th>Ph</th> <th>Amps</th> <th>Wire</th> </tr> </thead> <tbody> <tr> <td>208</td> <td>16,600</td> <td>3</td> <td>47.3</td> <td>3</td> </tr> <tr> <td>220</td> <td>13,948</td> <td>3</td> <td>37.6</td> <td>3</td> </tr> <tr> <td>240</td> <td>16,600</td> <td>3</td> <td>41.0</td> <td>3</td> </tr> <tr> <td>440</td> <td>13,948</td> <td>3</td> <td>18.8</td> <td>3</td> </tr> <tr> <td>480</td> <td>16,600</td> <td>3</td> <td>20.5</td> <td>3</td> </tr> </tbody> </table>		Volts	Watts	Ph	Amps	Wire	208	16,600	3	47.3	3	220	13,948	3	37.6	3	240	16,600	3	41.0	3	440	13,948	3	18.8	3	480	16,600	3	20.5	3	35 psi minimum 60 psi maximum Ⓞ 1/2" Dia. NPT for Generator (for water treatment connection) Ⓞ 1/2" Dia. NPT for Condenser	1 1/2" dia. Do not connect other units to this drain Drain must not be located beneath the steamer itself. Preferred floor drain location should be a minimum distance (from the unit) of at least 12" from the left side, 12" from the right side, 6" from the front and 6" from the rear Do not use PVC pipe	Right - 3", Left - 3", Rear - 3" (12" on control side if adjoining wall or equipment is over 30" high for service access) <b>Contact factory for variances to clearances.</b>
Volts	Watts	Ph	Amps	Wire																																																														
208	32,600	3	91.7	3																																																														
220	27,393	3	72.9	3																																																														
240	32,600	3	79.5	3																																																														
440	27,393	3	36.4	3																																																														
480	32,600	3	39.8	3																																																														
Volts	Watts	Ph	Amps	Wire																																																														
208	16,600	3	47.3	3																																																														
220	13,948	3	37.6	3																																																														
240	16,600	3	41.0	3																																																														
440	13,948	3	18.8	3																																																														
480	16,600	3	20.5	3																																																														

TOTAL CAPACITY (2 Compartments)	UTILITY CONNECTIONS
10 — 12" x 20" x 2 1/2" Cafeteria Pans or 20 — 12" x 20" x 1" Cafeteria Pans or 6 — 12" x 20" x 4" Cafeteria Pans	Ⓜ Electrical Supply Ⓛ Drain: 1.50" Dia. Ⓞ Cold Water Supply for Condenser 3/8" Dia. NPT Ⓞ Inlet for Generator Deliming Solution Ⓞ Cold Water Supply for Generator and Water Injection. 3/8" Dia. NPT (for water treatment conn.) Unit comes with a 50 Mesh Water Strainer (installation required)

**NOTES:**

Cleveland Range reserves right of design improvement or modification, as warranted.  
 Many regional, state and local codes exist and it is the responsibility of the owner and installer to comply with the codes.  
 Cleveland Range equipment is built to comply with applicable standards for manufacturers. Included among those approval agencies are U.L./NSF#4 and CSA (AGA, CGA).

(NOT TO SCALE)

## **Lakeside Middle School Specifications**

**Provide a double deck combi oven consisting of (2) Each Gas, 6 pan, boiler based combi ovens- Basis of design - Cleveland Convotherm Model C4eT-6.20GB with the following features and scope of work:**

1. Disappearing door features which enables oven door to be slid back beside the oven. This allows the door to be out of the way when loading and unloading the oven for safety, labor savings, efficiency, and convenience.
2. Hands free fully automatic cleaning system with Eco, regular, and express modes. Cleaning chemicals must be in liquid form, and include a cleaner (Convoclean) and a neutralizer (Convocare). No manual handling of sprays or pucks will be allowed for safety and labor saving reasons. Automatic cleaning system will also go into a forced rinse for three minutes if the cleaning cycle is interrupted for any reason such as power outage. This will insure that no cleaning chemicals are ever allowed to remain in the cooking cavity. System to also have single-dose dispensing option.
3. Advanced Closed System +.
4. Crisp and Tasty demoinsturizing feature with five moisture removal settings that can be programmed into recipes.
5. Easy Touch controls with 9" full screen, 399 cooking profiles with up to 20 steps for each recipe, Press and Go quick select buttons, and tray timer - oven load management for different products at the same time.
6. USB port for easy downloading or uploading of recipes.
7. Capacity of (6) 18" x 26" sheet pans or (12) 12" x 20" x 2-1/2" deep full size steam table pans.
8. Retractable hand shower for spraying and cleaning oven compartment.
9. Antibacterial door handle which contains silver ions to stop the growth of microorganisms.
10. BakePro- five levels of traditional baking.
11. HumidityPro – five levels of humidity settings,
12. Auto reversing fan for even cooking with five speeds.
13. Vented double glass door with hinged inner glass that snaps out for easy cleaning.
14. Multi- point core temperature probe that uses the lowest reading to control the cooking process.
15. Two each Optipure Model QT1+CR filter systems
16. (12) wire shelves.

17. (12) CWB-10 wire frying baskets - 12" x 20".
18. Provide stacking kit with 13.8" base, model 3431606 which is compatible with chemical drawer
19. Provide model 3471200 chemical drawer
20. Provide (2) each 11000115805 Installation Kits (one per combi deck)
21. Provide (2) each gas quick disconnect hoses
22. Three year parts and labor warranty.
23. Natural gas

Vendor to remove existing double deck convection ovens and take to loading dock or place within school requested. Vendor to receive, deliver, uncrate and install new double deck combi and filter. Vendor to provide all final electrical, gas, water and drain connections.

# Combi steamer

Project \_\_\_\_\_  
 Item \_\_\_\_\_  
 Quantity \_\_\_\_\_  
 FCSI section \_\_\_\_\_  
 Approval \_\_\_\_\_  
 Date \_\_\_\_\_

C4eT 6.20 GB

## Model

Convotherm 4 easyTouch

- easyTouch
- 7 slide rails
- Gas
- Boiler
- Right-hinged door



## Key features

- ACS+ operating modes: Steam, combi-steam, hot air
- ACS+ extra functions:
  - Crisp&Tasty - 5 moisture-removal settings
  - BakePro - 5 levels of traditional baking
  - HumidityPro - 5 humidity settings
  - Controllable fan - 5 speed settings
- easyTouch 9" full-touch screen
- ConvoClean+ fully automatic cleaning system with eco, regular and express modes - with optional single-dose dispensing
- Ethernet interface (LAN)
- HygienicCare
- USB port integrated in the control panel
- TriColor indicator ring - indicates the current operating status
- Steam generated by high-performance boiler outside the cooking chamber
- Right-hinged door

## Standard features

- ACS+ (Advanced Closed System +) operating modes:
  - Steam (86-266°F) with guaranteed steam saturation
  - Combi-steam (86-482°F) with automatic humidity adjustment
  - Hot air (86-482°F) with optimized heat transfer
- HygienicCare - food safety provided by antibacterial surfaces:
  - easyTouch control panel
  - Door handle and recoil hand shower
- easyTouch user interface:
  - 9" full-touch screen
  - Press&Go - automatic cooking with quick-select buttons
  - TrayTimer - oven-load management for different products at the same time
  - Regenerate+ - flexible multi-mode retherm function
  - ecoCooking - energy-save function
  - Low-temperature cooking / Delta-T cooking
  - Cook&Hold - cook and hold in one process
  - 399 cooking profiles each containing up to 20 steps
  - On-screen help with topic-based video function
  - Start-time preset
- Multi-point core temperature probe
- Door handle with safety latch and slam function
- Data storage for HACCP and pasteurization figures
- Preheat and Cool down function

## Options

- Disappearing door – more space and added safety (see page 2)
- ConvoGrill with grease management function (upon request)
- ConvoSmoke - built in food-smoking
- Available in various voltages
- Sous-vide probe, external connection
- Core temperature probe, external connection

## Accessories

- ConvoLink HACCP and cooking-profile management PC software
- Signal tower - indicates the operating status from a distance
- Banquet system (optionally as a package or individually): Plate rack, mobile shelf rack, transport trolley, thermal cover
- Equipment stands in various sizes and designs
- Racks for cooking and baking
- Stacking kits
- Cleaning products for the fully automatic ConvoClean+ cleaning system and the semi-automatic cleaning system



**Front view**

(disappearing door optional)

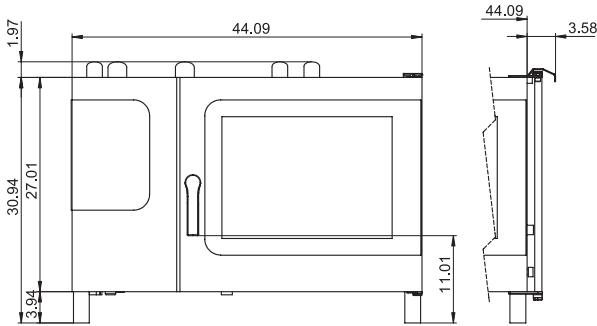

**Connection positions**

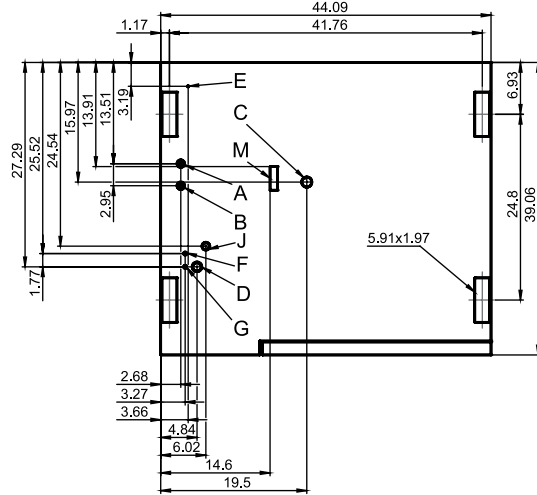

**View from above with wall clearances**

(disappearing door optional)

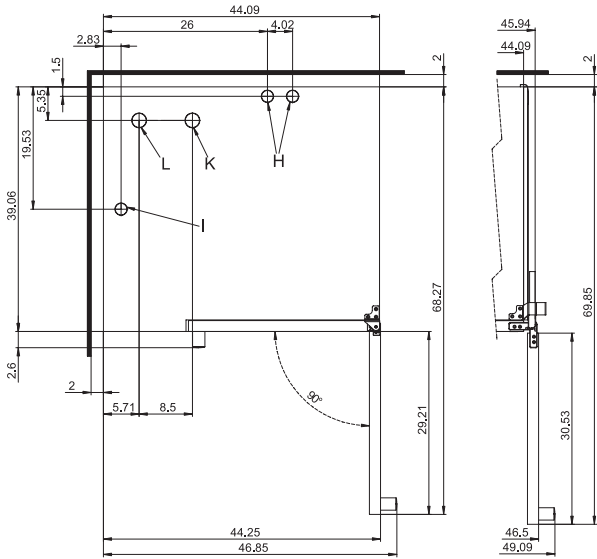

- A** Water connections (for boiler)
- B** Water connections (for cleaning, recoil hand shower)
- C** Drain connection (2" I. D.)
- D** Electrical connection
- E** Electrical ground
- F** Rinse-aid connection
- G** Cleaning-agent connection
- H** Air vent (2" I. D.)
- I** Ventilation port
- J** Gas connection
- K** Exhaust outlet (cooking compartment heating element)
- M** Safety overflow 3.2" x 1"

**Installation requirements**

Max. absolute appliance inclination during operation\*      max. 2° (3.4%)

\* Adjustable appliance feet as standard.

**Dimensions and weights**

**Dimensions including packaging**

Width x Height x Depth      53" x 39.8" x 44.9"

**Weight**

Net weight without options\* / accessories      437 lbs

Packaging weight      66 lbs

**Safety clearances\*\***

Rear	2"
Right (right-hinged door)	2"
Right (disappearing door pushed back)	5"
Left (18" clearance recommended for service)	2"
Top***	39"

\* Max. weight of options: 42 lbs.

\*\* Minimum clearance from heat sources: 20".

\*\*\* Depends on the type of exhaust system and the ceiling's characteristics.

### Loading capacity

**Max. number of food containers**

[Unit has 7 slide rails; rail spacing 2.68" max.]

Steam table pans (12"x20"x1")	12
Steam table pans (12"x20"x2.5")	12
Wire shelves, full size (20"x26")	6
Sheet pans, full size (18"x26")*	6
Sheet pans, half size (12"x20")*	12
Frying baskets, half size (12"x20")	12
Plates (optional plate rack)	27

**Max. loading weight**

Per combi steamer	132 lbs
Per shelf level	33 lbs

\* Wire shelves required.

### Electrical supply

**120V 1PH 60Hz \***

Rated power consumption	0.6 kW
Rated current	7.5 A
Power supply wire gauge	14 AWG
Conductor insulation rating	194°F / 90°C

\* Prepared for connection to an energy optimizing system.

### Water connections

**Water supply**

Water supply	Two 3/4" I. D. GHT-M (garden hose adapter). The appliance is designed for a permanent hookup to the water supply that uses a connecting hose with a minimum diameter of 1/2"
Flow pressure	22 - 87 PSI / 1.5 - 6 bar

**Drain**

Drain version	Permanent hookup (recommended) or funnel waste trap
Type	2" I. D. (comes elbow-shaped as standard)
Slope for drainpipe	min. 3.5% (2°)

### Water quality

**Water connection A\* for boiler, Water connection B\* for cleaning, recoil hand shower**

General requirements	Drinking water, typically untreated water
TDS	70 - 360 ppm
Hardness	70 - 360 ppm (4 - 21 gpg)
pH value	6.5 - 8.5
Cl <sup>-</sup> (chloride)	max. 60 ppm
Cl <sub>2</sub> (free chlorine)	max. 0.2 ppm
SO <sub>4</sub> <sup>2-</sup> (sulfate)	max. 150 ppm
Fe (iron)	max. 0.1 ppm
SiO <sub>2</sub> (silica)	max. 13 ppm
NH <sub>2</sub> Cl (monochloramine)	max. 0.4 ppm
Temperature	max. 104°F / max. 40°C

\* See connection positions diagram, p. 2.

NOTICE: The owner/operator/purchaser must ensure that the water quality requirements are met. Otherwise the original equipment warranty is void.

### Emissions

<b>Heat emission</b>	
Latent	3400 BTU/h
Sensitive	3900 BTU/h
<b>Drain temperature</b>	max. 140°F / 60°C
<b>Decibel rating</b>	max. 70 dBA

### Water consumption

<b>Water connections A, B</b>	
Average consumption for cooking**	1.90 gph
Required flow rate	3.96 gpm

\*\* Incl. water required for cooling the wastewater.

NOTICE: See connection positions diagram, p. 2.

### Gas specifications

Type of gas	Natural gas, propane
Gas connection	1/2" NPT
<b>Flow pressure</b>	
Natural gas	5.5 - 14" WC
Propane	11 - 14" WC
<b>Heat output</b>	
For Natural gas, propane	
Convection burner	68200 BTU/h
Boiler burner	61400 BTU/h

**Please note:**

- Please refer to the Installation manual for further technical data and for instructions on installation and setup.
- Convotherm reserves the right of design improvement or modification, as warranted.
- There are numerous federal, national and local laws, regulations and standards. It is the responsibility of the owner and installer to observe these laws, regulations and standards (e.g. fire regulations and health and safety standards).
- Convotherm combi steamers are built to comply with the applicable standards for manufacturers.

### ACCESSORIES

(For more detailed information, please refer to the Accessories brochure.)

#### Stacking kit

Combinations allowed	6.20 on 6.20
	6.20 on 10.20

**If combining two gas units**

Select the "stacking kit for Convotherm 4 gas units"

**If combining one electrical unit and one gas unit in a stacking kit**

Select the "stacking kit for Convotherm 4 electrical units" if:

Bottom combi steamer	EB/ES
Top combi steamer	GB/GS

Select the "stacking kit for Convotherm 4 gas units" if:

Bottom combi steamer	GB/GS
Top combi steamer	EB/ES

#### Equipment stand

Standard support surface height	26.38"
---------------------------------	--------

9758235\_04 ENG\_USA 05/15. © 2015 Manitowoc. Please note that the product is being continuously improved and that, as a result, these specifications are subject to change without notice.

## Monticello High School Specifications

**Provide one each two compartment convection steamer,- Basis of design - Cleveland Model 24CGA10.2 with the following features:**

1. Heavy Duty stainless steel 14 gauge construction
2. 10 pan capacity
3. Must have two independent cooking compartments with high efficiency gas power burner generators
4. Must have ball valve drain control. No drain solenoid.
5. Must have compensating timers.
6. Must have two piece compartment door design.
7. Provide Optipure WBT-QT11-CR water filter system
8. 3<sup>rd</sup> year parts and labor warranty
9. Provide Dormont 1675NPKIT48 Gas connector kit
10. Natural gas

Vendor to remove existing steamer and take to loading dock or place in school requested. Vendor to receive, deliver, uncrate and install new steamer and filter. Vendor to provide all final electrical, gas, water and drain connections.

# SteamCraft® Gemini™ 10

TWO COMPARTMENT FLOOR MODEL DESIGN. PRESSURELESS  
CONVECTION STEAMER, TWIN, INDEPENDENT GAS-FIRED GENERATORS

Project \_\_\_\_\_  
 Item \_\_\_\_\_  
 Quantity \_\_\_\_\_  
 FCSI Section 11400 \_\_\_\_\_  
 Approved \_\_\_\_\_  
 Date \_\_\_\_\_

SteamCraft® Generator Style High Speed Convection Steamers

## Models

- 24-CGA-10.2



## Standard Features

- Cooking Capacity for up to ten 12" x 20" x 2 1/2" deep Cafeteria Pans, five each compartment.
- Totally independent cooking compartments, each has its' own generator, gas valve and water level controls - no shared components
- Exclusive High Efficiency Gas Power Burner (forced air) Generator: Produces more steam for faster cooking while lowering operating costs (72M BTU's per compartment)
- Easy Access Cleaning Port: Each generator has a delimiting port located on the outside, top of the unit
- Generator Steam Standby Mode: Holds generator at a steaming temperature, allows unit to start cooking quickly
- Each compartment has one, 60-Minute Electro-Mechanical Timer with "SureCook" load compensating feature. Manual Bypass Switch for constant steaming.
- Durable 14 Gauge, 304 Stainless Steel construction for cooking cavity and steam generator
- Exclusive Two-Piece Compartment door: Slammable, self-adjusting door provides and airtight seal, reversable door gasket for extended life
- Exclusive Gemini Drain/Power Control System: Simple, reliable 1/2" ball valve style drain automatically turns power ON/OFF
- Exclusive Brass Steam Jets distribute even-high velocity steam throughout cooking compartment for faster cooking times
- Easy, Front -Access Generator Controls comes with a pullout drawer for simple servicing of unit
- 6" Stainless Steel Adjustable Legs with Flanged Feet
- Approvals: CSA (AGA, CSA) and U.L./NSF#4
- Compartment Steam Shut-Off Switch when compartment door is opened

## Short Form Specifications

Shall be Two Compartments, Cleveland Convection Steamer series SteamCraft® Gemini™ 10, Model 24-CGA-10.2, Twin Gas Atmospheric Steam Generator, 72M BTU's input per compartment. Independent steam generator, gas valve and water level control system. Automatic Generator Blowdown. Steam Generator with Automatic Water Fill on start up. Exclusive remote probe-type water level controls. Exclusive Brass "Steam Jet" distribution system. Two-piece free-floating compartment door. Type 430 Stainless Steel exterior and cooking compartments. Pullout service drawer for controls and Gemini Drain/Power Control System. Exclusive Cold Water Condenser design. Choice of Compartment Controls. Manual By Pass for continuous steaming.

## Options & Accessories

- Electronic Timer with Compensating Feature (ETC)
- Propane Gas (PG)
- Dissolve® Descale Solution, 6 one gallon container w/ quart markings (106174)
- Water Filters
- Hinged Right Door, controls on right

KE004046-23

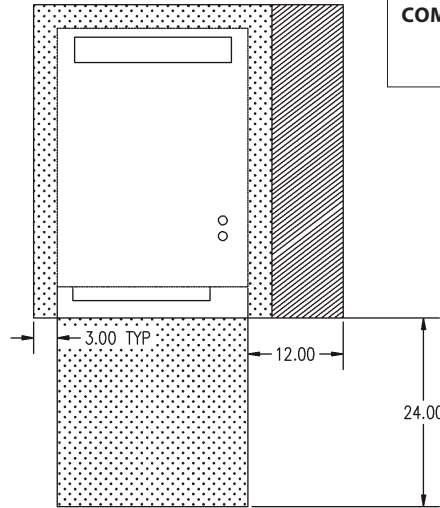
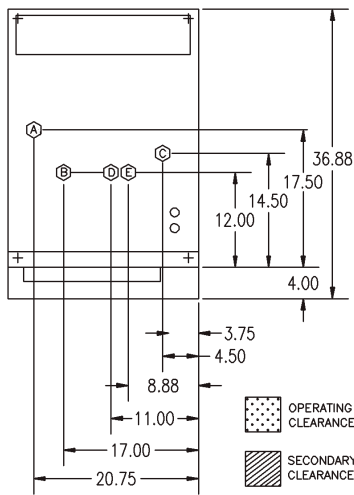

**COMPARTMENT HAS CAPACITY FOR:**

- Five, 12" x 20" x 2 1/2" deep Cafeteria Pans

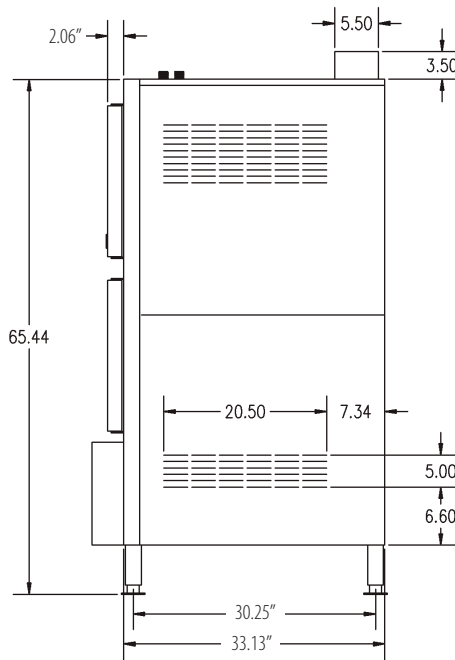
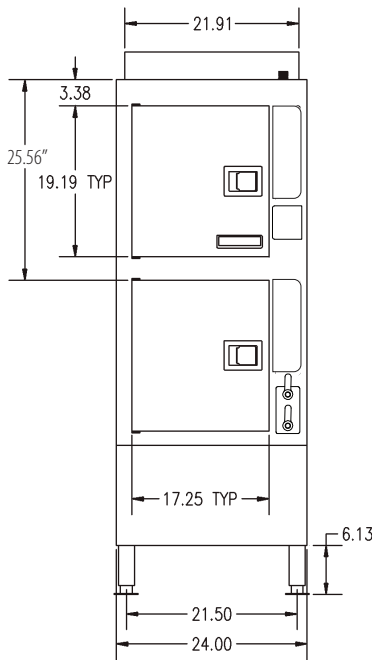

WATER QUALITY REQUIREMENTS (Boilers, Generators)	
TTDS:	50-250 ppm
Hardness:	50 - 200 mm (3 - 12 gpg)
pH value:	7.0 - 8.5
CL (Chloride):	max 50 ppm
Cl2 (free chlorine):	max 0.1 ppm
SiO2 (silica):	max 13 ppm
NH2Cl: (mono-chloramine)	max 0.1 ppm
Total Alkalinity:	50 - 100 ppm

A GAS			B ELECTRIC	CD COLD WATER	CLEARANCE	D DRAINAGE
1 1/4" IPS line size, 3/8" connection			120V-1Phase, 60 Hz. 2 Blowers & Controls 150 watts each  ** Do not connect to GFI outlet. See note below.	35 psi minimum 60 psi maximum  1/2" IPS-M NPT for Generator  1/2" IPS-M NPT for Condenser	Right - 3", Left - 3", Rear - 3"  (12" on control side if adjoining wall or equipment is over 30" high for service access)  <b>Contact factory for variances to clearances.</b>	1/2" IPS-M  Do not connect other units to this drain Drain must not be located beneath the steamer itself Preferred floor drain location should be a minimum distance (from the unit) of at least 12" from the left side, 12" from the right side, 6" from the front and 6" from the rear. Do not use PVC pipe
NATURAL	PROPANE	BTU				
Piping 3/8" N.P.T.	Piping 3/8" N.P.T.	72,000 each				
Supply pressure	Supply pressure	Generator,				
4.50" W.C. Min.	11.00" W.C. Min.	144,000 total				
14.00" W.C. Max.	14.00" W.C. Max.					
Manufacturer must be notified if unit will be used above 2,000 feet						

**NOTES:**  
 \*\*DO NOT CONNECT TO GFI OUTLET. CLEVELAND RANGE RECOMENDS GAS FIRED 120 VOLT STEAMERS BE HARD WIRED DIRECTLY TO ELECTRICAL SYSTEM.  
 Cleveland Range reserves right of design improvement or modification, as warranted.  
 Many regional, state and local codes exist and it is the responsibility of the owner and installer to comply with the codes.  
 Cleveland Range equipment is built to comply with applicable standards for manufacturers. Included among those approval agencies are U.L./NSF#4 and CSA (AGA, CGA).

(NOT TO SCALE)

## **Mountain View Elementary School Specifications**

**Provide a double deck combi oven consisting of (2) Each Gas, 6 pan, boiler based combi ovens- Basis of design - Cleveland Convotherm Model C4eT-6.20GB with the following features and scope of work:**

1. Disappearing door features which enables oven door to be slid back beside the oven. This allows the door to be out of the way when loading and unloading the oven for safety, labor savings, efficiency, and convenience.
2. Hands free fully automatic cleaning system with Eco, regular, and express modes. Cleaning chemicals must be in liquid form, and include a cleaner (Convoclean) and a neutralizer (Convocare). No manual handling of sprays or pucks will be allowed for safety and labor saving reasons. Automatic cleaning system will also go into a forced rinse for three minutes if the cleaning cycle is interrupted for any reason such as power outage. This will insure that no cleaning chemicals are ever allowed to remain in the cooking cavity. System to also have single-dose dispensing option.
3. Advanced Closed System +.
4. Crisp and Tasty demisting feature with five moisture removal settings that can be programmed into recipes.
5. Easy Touch controls with 9" full screen, 399 cooking profiles with up to 20 steps for each recipe, Press and Go quick select buttons, and tray timer - oven load management for different products at the same time.
6. USB port for easy downloading or uploading of recipes.
7. Capacity of (6) 18" x 26" sheet pans or (12) 12" x 20" x 2-1/2" deep full size steam table pans.
8. Retractable hand shower for spraying and cleaning oven compartment.
9. Antibacterial door handle which contains silver ions to stop the growth of microorganisms.
10. BakePro- five levels of traditional baking.
11. HumidityPro – five levels of humidity settings,
12. Auto reversing fan for even cooking with five speeds.
13. Vented double glass door with hinged inner glass that snaps out for easy cleaning.
14. Multi- point core temperature probe that uses the lowest reading to control the cooking process.
15. Two each Optipure Model QT1+CR filter systems
16. (12) wire shelves.
17. (12) CWB-10 wire frying baskets - 12" x 20".

18. Provide stacking kit with 13.8" base, model 3431606 which is compatible with chemical drawer
19. Provide model 3471200 chemical drawer
20. Provide (2) each 11000115805 Installation Kits (one per combi deck)
21. Three year parts and labor warranty.
22. Natural gas

Vendor to remove existing double deck convection ovens and take to loading dock.  
Vendor to receive, deliver, uncrate and install new double deck combi and filter. Vendor to provide all final electrical, water and drain connections.

# Combi steamer

Project \_\_\_\_\_  
 Item \_\_\_\_\_  
 Quantity \_\_\_\_\_  
 FCSI section \_\_\_\_\_  
 Approval \_\_\_\_\_  
 Date \_\_\_\_\_

C4eT 6.20 GB

## Model

Convotherm 4 easyTouch

- easyTouch
- 7 slide rails
- Gas
- Boiler
- Right-hinged door



## Key features

- ACS+ operating modes: Steam, combi-steam, hot air
- ACS+ extra functions:
  - Crisp&Tasty - 5 moisture-removal settings
  - BakePro - 5 levels of traditional baking
  - HumidityPro - 5 humidity settings
  - Controllable fan - 5 speed settings
- easyTouch 9" full-touch screen
- ConvoClean+ fully automatic cleaning system with eco, regular and express modes - with optional single-dose dispensing
- Ethernet interface (LAN)
- HygienicCare
- USB port integrated in the control panel
- TriColor indicator ring - indicates the current operating status
- Steam generated by high-performance boiler outside the cooking chamber
- Right-hinged door

## Standard features

- ACS+ (Advanced Closed System +) operating modes:
  - Steam (86-266°F) with guaranteed steam saturation
  - Combi-steam (86-482°F) with automatic humidity adjustment
  - Hot air (86-482°F) with optimized heat transfer
- HygienicCare - food safety provided by antibacterial surfaces:
  - easyTouch control panel
  - Door handle and recoil hand shower
- easyTouch user interface:
  - 9" full-touch screen
  - Press&Go - automatic cooking with quick-select buttons
  - TrayTimer - oven-load management for different products at the same time
  - Regenerate+ - flexible multi-mode retherm function
  - ecoCooking - energy-save function
  - Low-temperature cooking / Delta-T cooking
  - Cook&Hold - cook and hold in one process
  - 399 cooking profiles each containing up to 20 steps
  - On-screen help with topic-based video function
  - Start-time preset
- Multi-point core temperature probe
- Door handle with safety latch and slam function
- Data storage for HACCP and pasteurization figures
- Preheat and Cool down function

## Options

- Disappearing door – more space and added safety (see page 2)
- ConvoGrill with grease management function (upon request)
- ConvoSmoke - built in food-smoking
- Available in various voltages
- Sous-vide probe, external connection
- Core temperature probe, external connection

## Accessories

- ConvoLink HACCP and cooking-profile management PC software
- Signal tower - indicates the operating status from a distance
- Banquet system (optionally as a package or individually): Plate rack, mobile shelf rack, transport trolley, thermal cover
- Equipment stands in various sizes and designs
- Racks for cooking and baking
- Stacking kits
- Cleaning products for the fully automatic ConvoClean+ cleaning system and the semi-automatic cleaning system



**Front view**

(disappearing door optional)

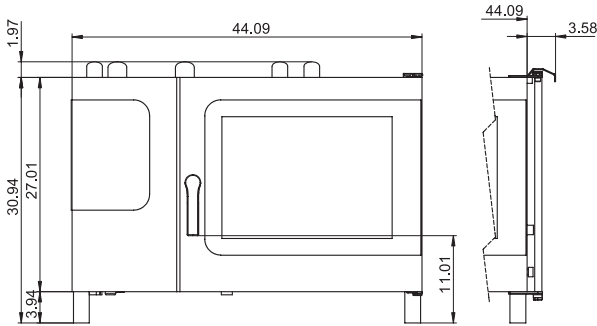

**Connection positions**

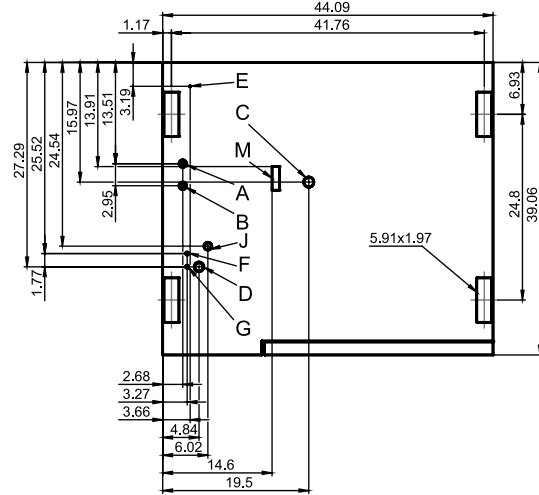

**View from above with wall clearances**

(disappearing door optional)

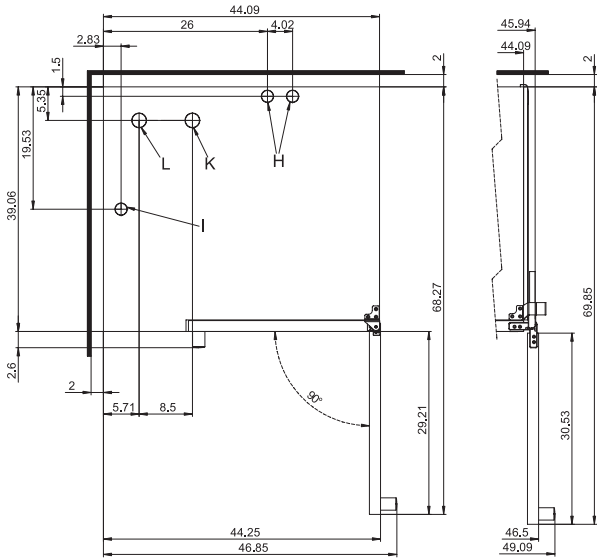

- A** Water connections (for boiler)
- B** Water connections (for cleaning, recoil hand shower)
- C** Drain connection (2" I. D.)
- D** Electrical connection
- E** Electrical ground
- F** Rinse-aid connection
- G** Cleaning-agent connection
- H** Air vent (2" I. D.)
- I** Ventilation port
- J** Gas connection
- K** Exhaust outlet (cooking compartment heating element)
- M** Safety overflow 3.2" x 1"

**Installation requirements**

Max. absolute appliance inclination during operation\* max. 2° (3.4%)

\* Adjustable appliance feet as standard.

**Dimensions and weights**

**Dimensions including packaging**

Width x Height x Depth 53" x 39.8" x 44.9"

**Weight**

Net weight without options\* / accessories 437 lbs

Packaging weight 66 lbs

**Safety clearances\*\***

Rear 2"

Right (right-hinged door) 2"

Right (disappearing door pushed back) 5"

Left (18" clearance recommended for service) 2"

Top\*\*\* 39"

\* Max. weight of options: 42 lbs.

\*\* Minimum clearance from heat sources: 20".

\*\*\* Depends on the type of exhaust system and the ceiling's characteristics.

### Loading capacity

**Max. number of food containers**

[Unit has 7 slide rails; rail spacing 2.68" max.]

Steam table pans (12"x20"x1")	12
Steam table pans (12"x20"x2.5")	12
Wire shelves, full size (20"x26")	6
Sheet pans, full size (18"x26")*	6
Sheet pans, half size (12"x20")*	12
Frying baskets, half size (12"x20")	12
Plates (optional plate rack)	27

**Max. loading weight**

Per combi steamer	132 lbs
Per shelf level	33 lbs

\* Wire shelves required.

### Electrical supply

**120V 1PH 60Hz \***

Rated power consumption	0.6 kW
Rated current	7.5 A
Power supply wire gauge	14 AWG
Conductor insulation rating	194°F / 90°C

\* Prepared for connection to an energy optimizing system.

### Water connections

**Water supply**

Water supply Two 3/4" I. D. GHT-M (garden hose adapter). The appliance is designed for a permanent hookup to the water supply that uses a connecting hose with a minimum diameter of 1/2"

Flow pressure 22 - 87 PSI / 1.5 - 6 bar

**Drain**

Drain version Permanent hookup (recommended) or funnel waste trap

Type 2" I. D. (comes elbow-shaped as standard)

Slope for drainpipe min. 3.5% (2°)

### Water quality

**Water connection A\* for boiler, Water connection B\* for cleaning, recoil hand shower**

General requirements	Drinking water, typically untreated water
TDS	70 - 360 ppm
Hardness	70 - 360 ppm (4 - 21 gpg)
pH value	6.5 - 8.5
Cl <sup>-</sup> (chloride)	max. 60 ppm
Cl <sub>2</sub> (free chlorine)	max. 0.2 ppm
SO <sub>4</sub> <sup>2-</sup> (sulfate)	max. 150 ppm
Fe (iron)	max. 0.1 ppm
SiO <sub>2</sub> (silica)	max. 13 ppm
NH <sub>2</sub> Cl (monochloramine)	max. 0.4 ppm
Temperature	max. 104°F / max. 40°C

\* See connection positions diagram, p. 2.

NOTICE: The owner/operator/purchaser must ensure that the water quality requirements are met. Otherwise the original equipment warranty is void.

### Emissions

**Heat emission**

Latent	3400 BTU/h
Sensitive	3900 BTU/h

<b>Drain temperature</b>	max. 140°F / 60°C
--------------------------	-------------------

<b>Decibel rating</b>	max. 70 dBA
-----------------------	-------------

### Water consumption

**Water connections A, B**

Average consumption for cooking**	1.90 gph
Required flow rate	3.96 gpm

\*\* Incl. water required for cooling the wastewater.

NOTICE: See connection positions diagram, p. 2.

### Gas specifications

Type of gas	Natural gas, propane
Gas connection	1/2" NPT

**Flow pressure**

Natural gas	5.5 - 14" WC
Propane	11 - 14" WC

**Heat output** For Natural gas, propane

Convection burner	68200 BTU/h
Boiler burner	61400 BTU/h

**Please note:**

- Please refer to the Installation manual for further technical data and for instructions on installation and setup.
- Convotherm reserves the right of design improvement or modification, as warranted.
- There are numerous federal, national and local laws, regulations and standards. It is the responsibility of the owner and installer to observe these laws, regulations and standards (e.g. fire regulations and health and safety standards).
- Convotherm combi steamers are built to comply with the applicable standards for manufacturers.

### ACCESSORIES

(For more detailed information, please refer to the Accessories brochure.)

#### Stacking kit

Combinations allowed	6.20 on 6.20
	6.20 on 10.20

**If combining two gas units**

Select the "stacking kit for Convotherm 4 gas units"

**If combining one electrical unit and one gas unit in a stacking kit**

Select the "stacking kit for Convotherm 4 electrical units" if:

Bottom combi steamer	EB/ES
Top combi steamer	GB/GS

Select the "stacking kit for Convotherm 4 gas units" if:

Bottom combi steamer	GB/GS
Top combi steamer	EB/ES

#### Equipment stand

Standard support surface height	26.38"
---------------------------------	--------

9758235\_04 ENG\_USA 05/15. © 2015 Manitowoc. Please note that the product is being continuously improved and that, as a result, these specifications are subject to change without notice.

## **Scottsville Elementary School Specifications**

**Provide (1) one each – Basis of design - Cleveland Model 24CEA-10 with the following features:**

1. Two independent, fully insulated steam generators mounted in rear.
2. Both generators to each have two 8 KW Fire Bar heating elements.
3. 14 gauge stainless steel construction for doors, cooking cavities, and steam generators.
4. Electro-mechanical controls.
5. Reversible gaskets.
6. Two generator cleaning ports located on top of unit.
7. Provide (1) each QT11-CR Optipure filter
8. Three year parts and labor warranty
9. 208 volt, 3 phase, 32 K.W.

Vendor to remove existing steamer and take to loading dock. Vendor to receive, deliver, uncrate and install new steamer and filter. Vendor to provide all final electrical, water and drain connections.

# SteamCraft® Gemini™ 10

TWO COMPARTMENT FLOOR MODEL DESIGN PRESSURELESS CONVECTION STEAMER TWIN ELECTRIC STEAM GENERATORS, 16 KW EACH

Project \_\_\_\_\_  
 Item \_\_\_\_\_  
 Quantity \_\_\_\_\_  
 FCSI Section 11400 \_\_\_\_\_  
 Approved \_\_\_\_\_  
 Date \_\_\_\_\_

SteamCraft® Generator Style High Speed Convection Steamers

## Models

- 24-CEA-10



Shown with optional Electronic Timer

## Standard Features

- Cooking Capacity for up to ten 12" x 20" x 2 1/2" deep Cafeteria Pans, five each compartment.
- Innovative PowerPak Electric Steam Generator: Twin Vertical Atmospheric Electric Steam Generators operate independently. Two 8 KW Fire Bar Heating Elements per generator. Strong 14 Gauge Stainless Steel Construction. Large 5 gallon generator reservoir for each compartment for high speed steam cooking production. Two fully insulated rear mounted independent steam generators.
- Each steam-cooking compartment is independently operated and controlled by a separate stainless steel steam generator.
- Easy Access Generator Cleaning Port: Two Generator Cleaning Ports located on the outside, top of the unit.
- Instant Steam Stand By Mode: Hold generator at a steaming temperature. Allows unit to start cooking instantly.
- Durable 14 Gauge, Stainless Steel Construction: For compartment door, cavity and steam generator.
- Two 60 Minute Electro-Mechanical Timers and Switches for manual operation: Audible signal for cooking time completion. (MCS)
- Main Power On/Off Switch: Automatically fills generator with water, and then starts heating elements in generator.
- Exclusive Steam Cooking Distribution System: Exclusive Brass Steam Jets produce a high velocity convection steam without fans. Coved Corner design in cooking compartment distributes heat evenly, and is easy to clean. Creased top & bottom enhance drainage. Cold Water Condenser for each compartment maintains a dry steam. Fully Insulated cooking compartment for thermal efficiency. Removable Stainless Steel Slide Racks.
- Automatic Generator Drain: Contains a "Water Jet" Spray Rinse Drain Cleaning Cycle to keep drain clear.
- Exclusive Automatic Probe for Water Level Control: Separate from the generator for easy access, contains a high velocity rinse cycle to eliminate mineral build up.
- Exclusive "Cool to the Touch" Two-Piece Compartment Door Design: Free floating inner door with reversible gasket provides an air tight seal. Stainless Steel Slam/Latch Door Latch mechanism for reliability.
- Condensate Drip Trough: Provide under lower compartment door to collect condensate.
- Left Hand Door Hinging: Compartment Doors hinged on the left, controls on the right.
- NSF Certified 6" Stainless Steel Legs with adjustable flanged feet for a one inch level adjustment.
- Compartment Door Steam Shut Off Switch (SCS)

## Short Form Specifications

Shall be Two Compartments, Cleveland Convection Steamer series SteamCraft® Gemini™ 10, Model 24-CEA-10, Twin Electric Atmospheric Steam Generator, 32 KW input. Remote Probe Type Water Level Controls. Steam Generator with Automatic Water Fill on start up. Automatic Generator Blowdown, Two each 16.5 KW Fire Bar Heating Elements. Choice of Compartment Controls, Manual By Pass Operation Mode, Exclusive Cold Water Condenser design, Type 430 Stainless Steel exterior and cooking compartments.

## Options & Accessories

- Right hand Door Hinging, Controls on the Right (DHR)
- Electronic Timer with Compensating Load Feature (ETC)
- 10" Stainless Steel Legs (LF10)
- Dissolve® Descale Solution, 6 one gallon container w/quart markings (106174)
- Cafeteria Pans in depths of 1", 2 1/2" and 4"
- Low Wattage Option, 8 KW each compartment (LWO)
- Water Filters

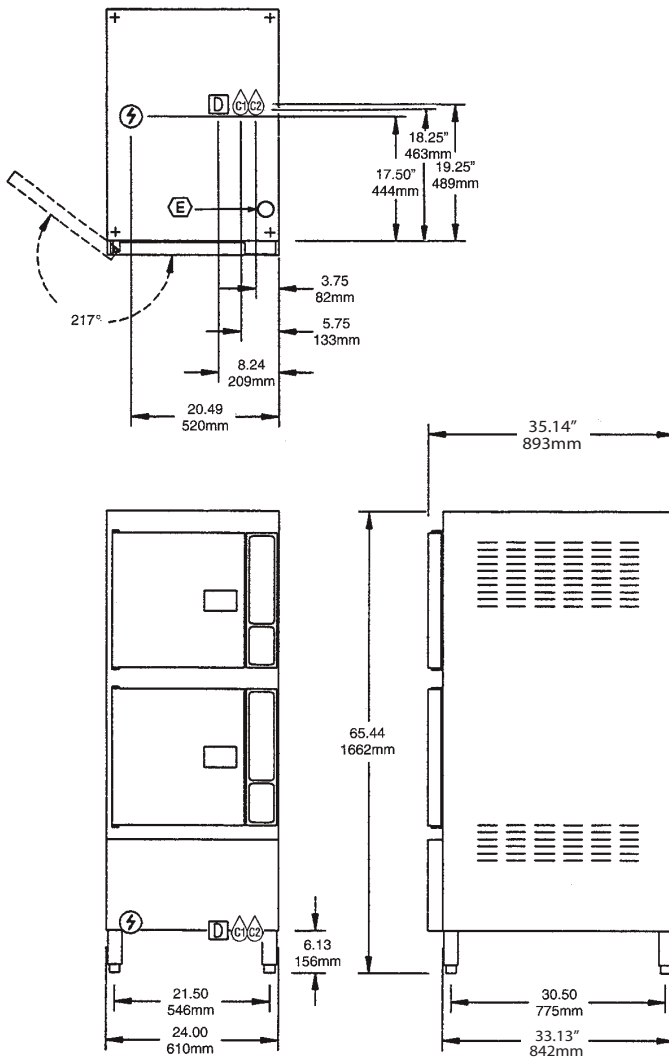

**COMPARTMENT HAS CAPACITY FOR:**

- Five, 12" x 20" x 2 1/2" deep Cafeteria Pans

WATER QUALITY REQUIREMENTS (Boilers, Generators)	
TTDS:	50-250 ppm
Hardness:	50 - 200 mm (3 - 12 gpg)
pH value:	7.0 - 8.5
CL (Chloride):	max 50 ppm
Cl <sub>2</sub> (free chlorine):	max 0.1 ppm
SiO <sub>2</sub> (silica):	max 13 ppm
NH <sub>2</sub> Cl:	max 0.1 ppm (mono-chloramine)
Total Alkalinity:	50 - 100 ppm
Water Pressure	35 - 80 PSI
Temperature:	max 104°F

ELECTRIC ⚡		COLD WATER (C1)(C2)	DRAINAGE (D)	CLEARANCE																																																														
<b>STANDARD ELECTRIC</b> <table border="1"> <thead> <tr> <th>Volts</th> <th>Watts</th> <th>Ph</th> <th>Amps</th> <th>Wire</th> </tr> </thead> <tbody> <tr> <td>208</td> <td>32,600</td> <td>3</td> <td>91.7</td> <td>3</td> </tr> <tr> <td>220</td> <td>27,393</td> <td>3</td> <td>72.9</td> <td>3</td> </tr> <tr> <td>240</td> <td>32,600</td> <td>3</td> <td>79.5</td> <td>3</td> </tr> <tr> <td>440</td> <td>27,393</td> <td>3</td> <td>36.4</td> <td>3</td> </tr> <tr> <td>480</td> <td>32,600</td> <td>3</td> <td>39.8</td> <td>3</td> </tr> </tbody> </table>		Volts	Watts	Ph	Amps	Wire	208	32,600	3	91.7	3	220	27,393	3	72.9	3	240	32,600	3	79.5	3	440	27,393	3	36.4	3	480	32,600	3	39.8	3	<b>LOW WATTAGE OPTION</b> <table border="1"> <thead> <tr> <th>Volts</th> <th>Watts</th> <th>Ph</th> <th>Amps</th> <th>Wire</th> </tr> </thead> <tbody> <tr> <td>208</td> <td>16,600</td> <td>3</td> <td>47.3</td> <td>3</td> </tr> <tr> <td>220</td> <td>13,948</td> <td>3</td> <td>37.6</td> <td>3</td> </tr> <tr> <td>240</td> <td>16,600</td> <td>3</td> <td>41.0</td> <td>3</td> </tr> <tr> <td>440</td> <td>13,948</td> <td>3</td> <td>18.8</td> <td>3</td> </tr> <tr> <td>480</td> <td>16,600</td> <td>3</td> <td>20.5</td> <td>3</td> </tr> </tbody> </table>		Volts	Watts	Ph	Amps	Wire	208	16,600	3	47.3	3	220	13,948	3	37.6	3	240	16,600	3	41.0	3	440	13,948	3	18.8	3	480	16,600	3	20.5	3	35 psi minimum 60 psi maximum 1/2" Dia. NPT for Generator (for water treatment connection) 3/8" Dia. NPT for Condenser	1 1/2" dia. Do not connect other units to this drain Drain must not be located beneath the steamer itself. Preferred floor drain location should be a minimum distance (from the unit) of at least 12" from the left side, 12" from the right side, 6" from the front and 6" from the rear Do not use PVC pipe	Right - 3", Left - 3", Rear - 3" (12" on control side if adjoining wall or equipment is over 30" high for service access) <b>Contact factory for variances to clearances.</b>
Volts	Watts	Ph	Amps	Wire																																																														
208	32,600	3	91.7	3																																																														
220	27,393	3	72.9	3																																																														
240	32,600	3	79.5	3																																																														
440	27,393	3	36.4	3																																																														
480	32,600	3	39.8	3																																																														
Volts	Watts	Ph	Amps	Wire																																																														
208	16,600	3	47.3	3																																																														
220	13,948	3	37.6	3																																																														
240	16,600	3	41.0	3																																																														
440	13,948	3	18.8	3																																																														
480	16,600	3	20.5	3																																																														

TOTAL CAPACITY (2 Compartments)	UTILITY CONNECTIONS	
10 — 12" x 20" x 2 1/2" Cafeteria Pans or 20 — 12" x 20" x 1" Cafeteria Pans or 6 — 12" x 20" x 4" Cafeteria Pans	(A) Electrical Supply (B) Cold Water Supply for Condenser 3/8" Dia. NPT (C) Cold Water Supply for Generator and Water Injection. 3/8" Dia. NPT (for water treatment conn.) Unit comes with a 50 Mesh Water Strainer (installation required)	(D) Drain: 1.50" Dia. (E) Inlet for Generator Deliming Solution

**NOTES:**  
 Cleveland Range reserves right of design improvement or modification, as warranted.  
 Many regional, state and local codes exist and it is the responsibility of the owner and installer to comply with the codes.  
 Cleveland Range equipment is built to comply with applicable standards for manufacturers. Included among those approval agencies are U.L./NSF#4 and CSA (AGA, CGA).

(NOT TO SCALE)

## **Stone Robinson Elementary School Specifications**

**Provide (1) one each – Basis of design - Cleveland Model 24CEA-10 with the following features:**

1. Two independent, fully insulated steam generators mounted in rear.
2. Both generators to each have two 8 KW Fire Bar heating elements.
3. 14 gauge stainless steel construction for doors, cooking cavities, and steam generators.
4. Electro-mechanical controls.
5. Reversible gaskets.
6. Two generator cleaning ports located on top of unit.
7. Provide (1) each QT11-CR Optipure filter
8. Three year parts and labor warranty
9. 208 volt, 3 phase, 32 K.W.

Vendor to remove existing steamer and take to loading dock or place in school where requested. Vendor to receive, deliver, uncrate and install new steamer and filter. Vendor to provide all final electrical, water and drain connections.

# SteamCraft® Gemini™ 10

TWO COMPARTMENT FLOOR MODEL DESIGN PRESSURELESS CONVECTION STEAMER TWIN ELECTRIC STEAM GENERATORS, 16 KW EACH

Project \_\_\_\_\_  
 Item \_\_\_\_\_  
 Quantity \_\_\_\_\_  
 FCSI Section 11400 \_\_\_\_\_  
 Approved \_\_\_\_\_  
 Date \_\_\_\_\_

SteamCraft® Generator Style High Speed Convection Steamers

## Models

- 24-CEA-10



Shown with optional Electronic Timer

## Standard Features

- Cooking Capacity for up to ten 12" x 20" x 2 1/2" deep Cafeteria Pans, five each compartment.
- Innovative PowerPak Electric Steam Generator: Twin Vertical Atmospheric Electric Steam Generators operate independently. Two 8 KW Fire Bar Heating Elements per generator. Strong 14 Gauge Stainless Steel Construction. Large 5 gallon generator reservoir for each compartment for high speed steam cooking production. Two fully insulated rear mounted independent steam generators.
- Each steam-cooking compartment is independently operated and controlled by a separate stainless steel steam generator.
- Easy Access Generator Cleaning Port: Two Generator Cleaning Ports located on the outside, top of the unit.
- Instant Steam Stand By Mode: Hold generator at a steaming temperature. Allows unit to start cooking instantly.
- Durable 14 Gauge, Stainless Steel Construction: For compartment door, cavity and steam generator.
- Two 60 Minute Electro-Mechanical Timers and Switches for manual operation: Audible signal for cooking time completion. (MCS)
- Main Power On/Off Switch: Automatically fills generator with water, and then starts heating elements in generator.
- Exclusive Steam Cooking Distribution System: Exclusive Brass Steam Jets produce a high velocity convection steam without fans. Coved Corner design in cooking compartment distributes heat evenly, and is easy to clean. Creased top & bottom enhance drainage. Cold Water Condenser for each compartment maintains a dry steam. Fully Insulated cooking compartment for thermal efficiency. Removable Stainless Steel Slide Racks.
- Automatic Generator Drain: Contains a "Water Jet" Spray Rinse Drain Cleaning Cycle to keep drain clear.
- Exclusive Automatic Probe for Water Level Control: Separate from the generator for easy access, contains a high velocity rinse cycle to eliminate mineral build up.
- Exclusive "Cool to the Touch" Two-Piece Compartment Door Design: Free floating inner door with reversible gasket provides an air tight seal. Stainless Steel Slam/Latch Door Latch mechanism for reliability.
- Condensate Drip Trough: Provide under lower compartment door to collect condensate.
- Left Hand Door Hinging: Compartment Doors hinged on the left, controls on the right.
- NSF Certified 6" Stainless Steel Legs with adjustable flanged feet for a one inch level adjustment.
- Compartment Door Steam Shut Off Switch (SCS)

## Short Form Specifications

Shall be Two Compartments, Cleveland Convection Steamer series SteamCraft® Gemini™ 10, Model 24-CEA-10, Twin Electric Atmospheric Steam Generator, 32 KW input. Remote Probe Type Water Level Controls. Steam Generator with Automatic Water Fill on start up. Automatic Generator Blowdown, Two each 16.5 KW Fire Bar Heating Elements. Choice of Compartment Controls, Manual By Pass Operation Mode, Exclusive Cold Water Condenser design, Type 430 Stainless Steel exterior and cooking compartments.

## Options & Accessories

- Right hand Door Hinging, Controls on the Right (DHR)
- Electronic Timer with Compensating Load Feature (ETC)
- 10" Stainless Steel Legs (LF10)
- Dissolve® Descale Solution, 6 one gallon container w/quart markings (106174)
- Cafeteria Pans in depths of 1", 2 1/2" and 4"
- Low Wattage Option, 8 KW each compartment (LWO)
- Water Filters

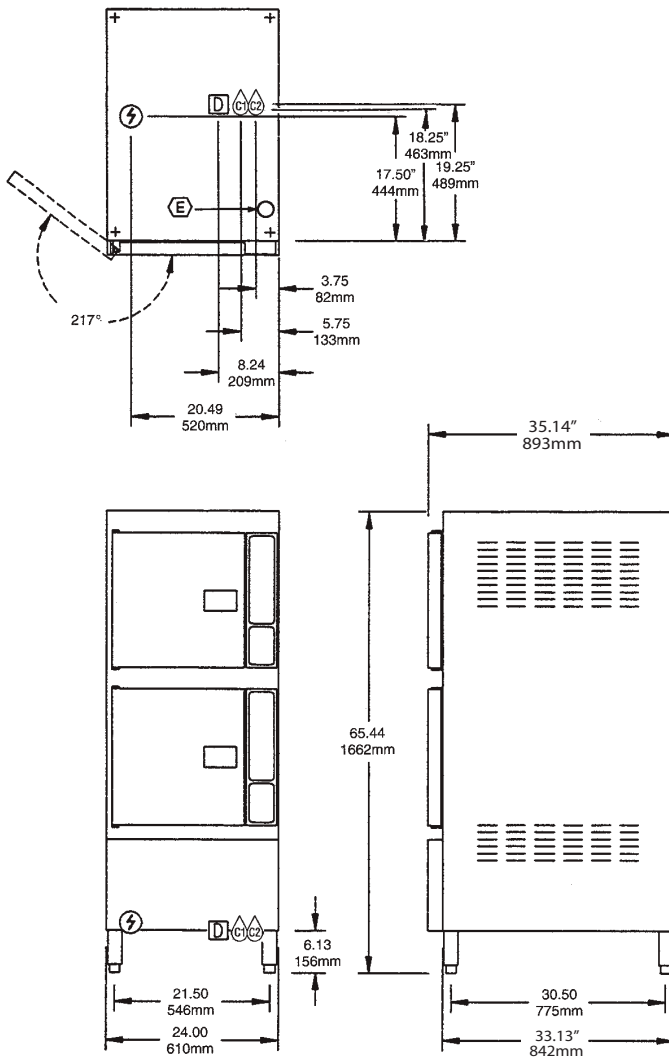

**COMPARTMENT HAS CAPACITY FOR:**

- Five, 12" x 20" x 2 1/2" deep Cafeteria Pans

**WATER QUALITY REQUIREMENTS (Boilers, Generators)**

TTDS:	50-250 ppm
Hardness:	50 - 200 mm (3 - 12 gpg)
pH value:	7.0 - 8.5
CL (Chloride):	max 50 ppm
Cl <sub>2</sub> (free chlorine):	max 0.1 ppm
SiO <sub>2</sub> (silica):	max 13 ppm
NH <sub>2</sub> Cl:	max 0.1 ppm (mono-chloramine)
Total Alkalinity:	50 - 100 ppm
Water Pressure	35 - 80 PSI
Temperature:	max 104°F

ELECTRIC ⚡		COLD WATER ⓄⓂ	DRAINAGE Ⓛ	CLEARANCE																																																														
<b>STANDARD ELECTRIC</b> <table border="1"> <thead> <tr> <th>Volts</th> <th>Watts</th> <th>Ph</th> <th>Amps</th> <th>Wire</th> </tr> </thead> <tbody> <tr> <td>208</td> <td>32,600</td> <td>3</td> <td>91.7</td> <td>3</td> </tr> <tr> <td>220</td> <td>27,393</td> <td>3</td> <td>72.9</td> <td>3</td> </tr> <tr> <td>240</td> <td>32,600</td> <td>3</td> <td>79.5</td> <td>3</td> </tr> <tr> <td>440</td> <td>27,393</td> <td>3</td> <td>36.4</td> <td>3</td> </tr> <tr> <td>480</td> <td>32,600</td> <td>3</td> <td>39.8</td> <td>3</td> </tr> </tbody> </table>		Volts	Watts	Ph	Amps	Wire	208	32,600	3	91.7	3	220	27,393	3	72.9	3	240	32,600	3	79.5	3	440	27,393	3	36.4	3	480	32,600	3	39.8	3	<b>LOW WATTAGE OPTION</b> <table border="1"> <thead> <tr> <th>Volts</th> <th>Watts</th> <th>Ph</th> <th>Amps</th> <th>Wire</th> </tr> </thead> <tbody> <tr> <td>208</td> <td>16,600</td> <td>3</td> <td>47.3</td> <td>3</td> </tr> <tr> <td>220</td> <td>13,948</td> <td>3</td> <td>37.6</td> <td>3</td> </tr> <tr> <td>240</td> <td>16,600</td> <td>3</td> <td>41.0</td> <td>3</td> </tr> <tr> <td>440</td> <td>13,948</td> <td>3</td> <td>18.8</td> <td>3</td> </tr> <tr> <td>480</td> <td>16,600</td> <td>3</td> <td>20.5</td> <td>3</td> </tr> </tbody> </table>		Volts	Watts	Ph	Amps	Wire	208	16,600	3	47.3	3	220	13,948	3	37.6	3	240	16,600	3	41.0	3	440	13,948	3	18.8	3	480	16,600	3	20.5	3	35 psi minimum 60 psi maximum Ⓞ 1/2" Dia. NPT for Generator (for water treatment connection) Ⓜ 1/2" Dia. NPT for Condenser	1 1/2" dia. Do not connect other units to this drain Drain must not be located beneath the steamer itself. Preferred floor drain location should be a minimum distance (from the unit) of at least 12" from the left side, 12" from the right side, 6" from the front and 6" from the rear Do not use PVC pipe	Right - 3", Left - 3", Rear - 3" (12" on control side if adjoining wall or equipment is over 30" high for service access) <b>Contact factory for variances to clearances.</b>
Volts	Watts	Ph	Amps	Wire																																																														
208	32,600	3	91.7	3																																																														
220	27,393	3	72.9	3																																																														
240	32,600	3	79.5	3																																																														
440	27,393	3	36.4	3																																																														
480	32,600	3	39.8	3																																																														
Volts	Watts	Ph	Amps	Wire																																																														
208	16,600	3	47.3	3																																																														
220	13,948	3	37.6	3																																																														
240	16,600	3	41.0	3																																																														
440	13,948	3	18.8	3																																																														
480	16,600	3	20.5	3																																																														

TOTAL CAPACITY (2 Compartments)	UTILITY CONNECTIONS
10 — 12" x 20" x 2 1/2" Cafeteria Pans or 20 — 12" x 20" x 1" Cafeteria Pans or 6 — 12" x 20" x 4" Cafeteria Pans	Ⓜ Electrical Supply Ⓛ Drain: 1.50" Dia. Ⓞ Cold Water Supply for Condenser 3/8" Dia. NPT Ⓞ Cold Water Supply for Generator and Water Injection. 3/8" Dia. NPT (for water treatment conn.) Ⓛ Inlet for Generator Deliming Solution Unit comes with a 50 Mesh Water Strainer (installation required)

**NOTES:**

Cleveland Range reserves right of design improvement or modification, as warranted.  
 Many regional, state and local codes exist and it is the responsibility of the owner and installer to comply with the codes.  
 Cleveland Range equipment is built to comply with applicable standards for manufacturers. Included among those approval agencies are U.L./NSF#4 and CSA (AGA, CGA).

(NOT TO SCALE)